

Strategy Report





Staff Project Team:

Karen Cumbo, Director of Planning, Development & Transportation
Laurie Kadrich, Community Development & Neighborhood Services Director
Pete Wray, Senior City Planner (Project Manager)
Sherry Albertson-Clark, Interim Planning Manager
Karen McWilliams, Historic Preservation Planner
Josh Weinberg, Historic Preservation Planner
Peter Barnes, Zoning Supervisor
Ted Shepard, Chief Planner
Ginny Sawyer, Neighborhood Administrator
Courtney Levingston, City Planner

Contact: Pete Wray, Project Manager

970-221-6754

pwrap@fcgov.com

www.fcgov.com/advanceplanning/eastwestneighborhoods.php



Consultant Team:

Noré Winter, President
Abe Barge, Senior Planner
Mary Phillips, Senior Planner
1265 Yellow Pine Ave.
Boulder, CO 80304

www.winterandcompany.net

Report Contents

Executive Summary	1
Study Process Overview	2
Overview of Strategy Options	3
Project Phases	4
Next Steps	6
Neighborhood Profile	7
Community Identified Features	7
Neighborhood Development Patterns	9
Character Areas	28
Existing Regulations Summary	46
Recent Trends	51
Community Comments	55
Neighborhood Workshops	56
Working Groups	69
Questionnaires and Surveys	73
Community Comment Themes	82
Neighborhood Objectives and Issues	84
Potential Tools	85
Education and Communication	86
Process and Administration	89
Design Tools	93
Potential Application Strategies	108
Strategy Options	111
Selection Criteria	112
Scope and Application	113
Overview of Strategy Options	114
Strategy Options Detail	116
Potential Future Strategies	132
Appendix A: GIS Mapping Data	
Appendix B: Character Area Maps	
Appendix C: Building Permits	
Appendix D: Variances	

Study Area

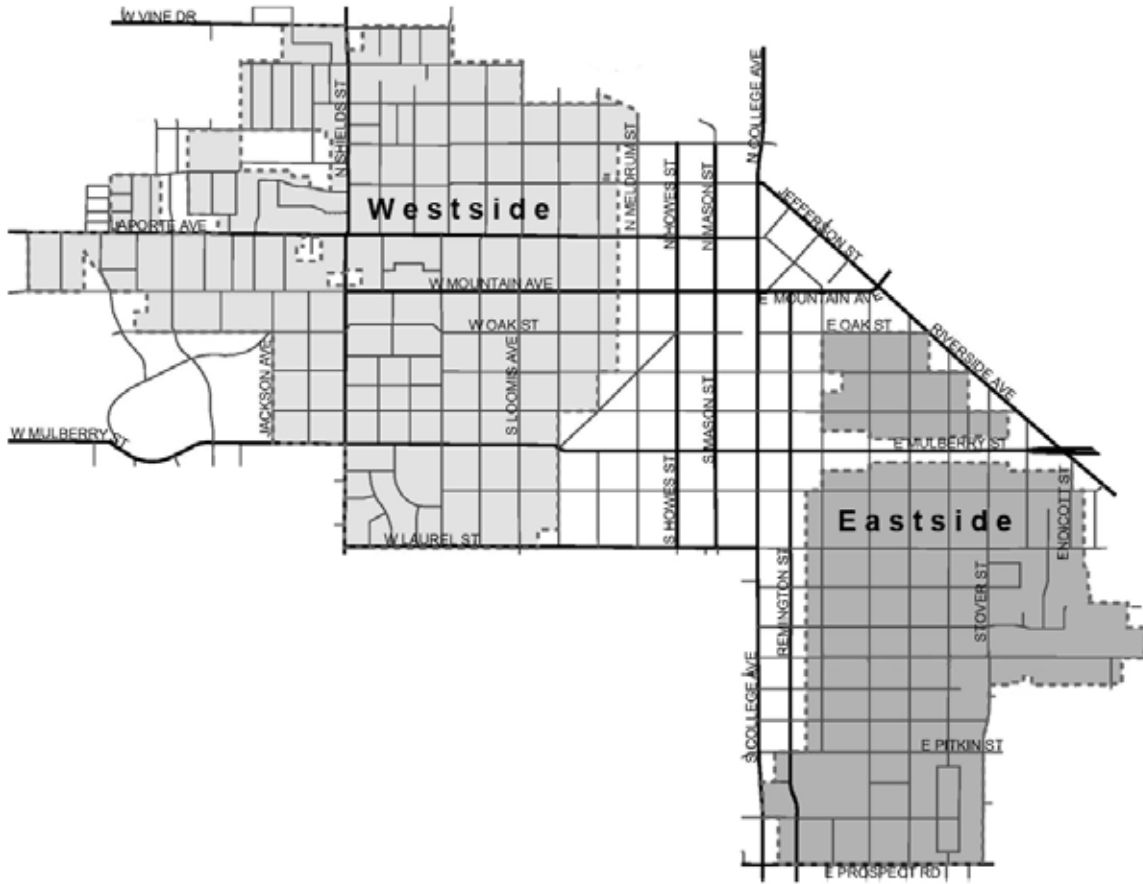

The study area includes the Neighborhood Conservation Low Density (N-C-L) and Neighborhood Conservation Medium Density (N-C-M) zoning districts, which encompass the core area neighborhoods near Downtown Fort Collins.

Executive Summary

The Eastside and Westside Neighborhood Character study seeks to evaluate neighborhood character and change in the core area neighborhoods near Downtown and identify strategies to retain and enhance their unique character and context. The study was initiated primarily in response to resident concerns about changes to the character of the neighborhoods as a result of demolition and new construction.

The community has struggled with issues related to the compatibility of new infill development in its older neighborhoods for many years. Although there have been incremental changes to regulations and programs, the community has not implemented a comprehensive system to address neighborhood compatibility since the 1991 adoption of the N-C-L and N-C-M zone districts that encompass the Eastside and Westside Neighborhoods.

Previous strategies and programs considered by City Council have included:

- 1995 Design Guidelines
- 2010 FAR Adjustments (rescinded)
- 2011 Landmark Preservation Commission Design Assistance Program

Some past strategies and programs have been criticized as too restrictive or as responding to a problem that does not exist, or is very limited in scope. Prior to moving forward with future strategies, the City has sought to better understand the issues and evaluate the potential impact of any proposed solutions.

This report documents the study process to date, provides background information on the character and context of the neighborhoods, summarizes community comments and presents strategy options for City Council consideration. The first draft of the report was published on November 1, 2012. This draft incorporates updates based on community comment received at the November 5 neighborhood workshop and through an online visual survey.



Study Process Overview

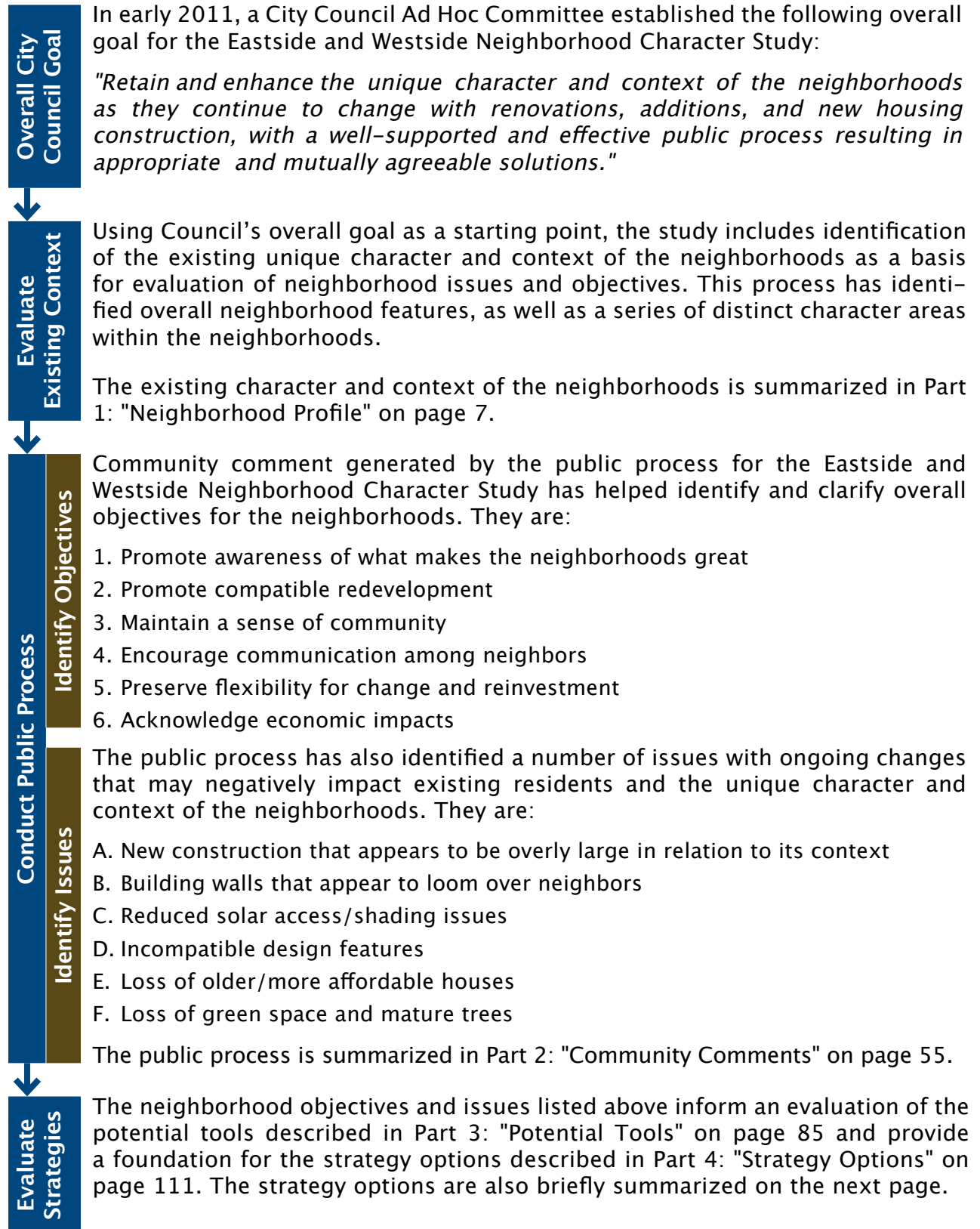

Overview of Strategy Options

As described in Part 4: "Strategy Options" on page 111, five strategy options have been developed to address the neighborhood objectives and issues summarized on the previous page. A sixth strategy option, "Take No Action" acknowledges feedback from some participants that there is not an issue, or that new tools and strategies should not be considered. See page 131 for information on strategies that were not selected.

The strategy options are briefly summarized below. City Council will provide direction on which options to pursue at a work session on November 27, 2012.

-
- ◆ **1. Promote Design Assistance.** This would promote access to, and use of the City's current design assistance program. Additional detail is provided on page 117.

 - ◆ **2. Expand Notification.** This would extend notification of requested variances exceeding a certain project size or other thresholds, to be determined, to allow for comment on pending changes in the neighborhoods. Additional detail is provided on page 118.

 - ✓ **3. Create Design Handbooks/Guidelines.** This would include development of voluntary design handbooks or guidelines to promote compatible development in unique character areas throughout the neighborhoods. Additional detail is provided on page 119.

 - ✓ **4. Adjust Measurement.** This would adjust the method for measuring building height at the minimum side yard setback and FAR to better account for the impact of tall walls on raised grade and high volume spaces. Additional detail is provided on page 121.

 - 5. Address Building Massing and Scale.** This would apply new or adjusted design standards (zoning requirements) to address the scale and solar access impacts of larger new construction and additions. One of the following options would be considered per direction from City Council:
 - ✗ **5a. Address Scale Directly** (not suggested). This would use revisions to existing maximum FAR standards to directly address building scale. Additional detail is provided on page 122.

 - ✗ **5b. Address Solar Access Directly** (not suggested). This would introduce a standard limiting the amount of shadow that new construction/additions could cast on a neighboring property based on an equivalent "solar fence." Note that this is not a suggested strategy option. Additional detail is provided on page 125.

 - ✓ **5c. Address Massing and Solar Impacts with Design Tools.** This would provide a menu of options for shaping the mass of new construction/additions exceeding a specific FAR threshold to address both massing and solar access. Additional detail is provided on page 125.

 - 6. Take No Action.** This would not introduce new regulatory tools or strategies. Additional detail is provided on page 131.

- Legend

 - ◆ = Strategy option suggested for early implementation.
 - ✓ = Strategy option suggested for further evaluation and development.
 - ✎ = Strategy option that would apply only to targeted properties/projects (would not apply to most new construction/additions)
 - ✗ = Strategy option that is not suggested at this time, but may be considered by City Council as an alternative.

Process Objectives



The Eastside and Westside Neighborhood Character Study seeks to:

- Define and understand a complete range of characteristics of the neighborhoods, as a basis for any new initiatives. Recognize differences in the characteristics of the neighborhoods.
- Use data to define the characteristics of the neighborhoods.
- Conduct a community involvement process for residents and other stakeholders to evaluate whether any characteristics warrant new solutions to help retain and enhance them.
- Continue the process noted above to derive solutions from the desires of residents, the Planning and Zoning Board, and the Landmark Preservation Commission, resulting in buy-in and informed consent.
- Include necessary funding or staffing resources in any solutions.
- Include testing and monitoring of any actions to evaluate objective results for effectiveness and consequences.

Project Phases

The Eastside and Westside Neighborhood Character Study is organized into four key phases that will be shaped by ideas that emerge along the way. At the end of each phase, City Council will determine how to proceed to the next phase.

Each phase of the study is briefly summarized below, and a schedule overview is provided on the next page. The study is currently near the conclusion of Phase 2.

Phase 1: Understand the Character and Context of the Neighborhoods

In this phase, the City gathered information from residents and other stakeholders about neighborhood attributes, objectives and issues using a variety of outreach strategies. Phase 1 was completed in July, 2012. The results are summarized in the *Phase 1 Report*, and in the *Neighborhood Profile* and *Community Comments* sections of this report.

Phase 2: Develop a Strategy

With Council direction, the City began this phase in August, 2012. It focuses on development of a strategy to address the neighborhood objectives and issues identified in Phase 1. This report summarizes the results of Phase 1 and 2, and presents strategy options for City Council consideration.

Phase 3: Develop Tools and Systems to Implement the Strategy

At a work session on November 27, 2012, City Council will determine whether to proceed to Phase 3. They will also provide direction on which strategy options described in this report should be further evaluated for potential development and implementation in Phase 4.

Phase 4: Place the Tools into Action

If this phase is authorized, City Council will hold public hearings to consider adoption of tools to enhance the unique character and context of the neighborhoods while addressing identified neighborhood objectives and issues.



Eastside and Westside Neighborhoods Character Study

Project Schedule Chart	2012												2013		
	May	June	July	August	September	October	November	December	January	February					
Phase 1: Evaluate Context, Concerns and Objectives															
Project Kickoff															
Stakeholder Working Groups															
Neighborhood Questionnaire															
Neighborhood Workshops															
Phase 1 Summary Report															
City Council Work Session															
Phase 2: Develop Strategy															
Review and Update Process															
Neigh. Character Evaluation															
Initial Phase 2 Working Groups															
Develop Preliminary Strategy															
Economic Analysis															
Follow-up Phase 2 Working Groups															
Visual Survey															
Neighborhood Workshop															
Peer Panel (if needed)															
Final Strategy															
City Council Work Session															
Phase 3: Develop Tools to Implement Strategy															
Draft Early Implementation Tools															
Assess Additional Tools															
Draft Additional Tools															
Phase 3 Working Groups															
Public Open House (if needed)															
Phase 4: Adoption															
Adoption Hearing #1 (early implementation tools)															
Adoption Hearing #2 (additional tools)															



Next Steps

This report will be presented to City Council at a work session on November 27, 2012. Based on City Council direction, some strategy options may be developed for early implementation in January or February, 2013. City Council may also select additional strategy options for further evaluation and development after February, 2013. See "Project Phases" on page 4 for more information.

Part 1

Neighborhood Profile

The Eastside and Westside Neighborhoods are diverse, with a range of existing character and contexts. These conditions help shape development and may influence its perceived compatibility. Understanding neighborhood characteristics, including physical conditions and dynamic aspects such as past and future changes, is an important part of this study.

This part of the report outlines existing conditions in the neighborhoods. It begins with a summary of features identified by participants in the public process, followed by a statistical description of overall development patterns and unique subareas, or "character areas" within the neighborhoods. It concludes with a description of existing regulations and information about recent trends in the neighborhoods.



Community Identified Features

As part of the project's community engagement process, members of the community were asked to identify and describe a series of features which make the neighborhood unique and desirable to live in.

Feedback from residents was largely consistent and included both physical and social characteristics. The most common traits participants described include friendly neighbors, diversity in people and buildings, and walkability. The following sections summarize the most commonly identified qualitative and physical neighborhood features of value to residents.

Part 1 Contents

Community Identified Features	7
Neighborhood Development Patterns... 9	
Using this Information	9
About the Maps Used in This Section	10
The Eastside Neighborhood	10
The Westside Neighborhood	19
Character Areas	28
Character Area 1	32
Character Area 2	34
Character Area 4	38
Character Area 5	40
Character Area 6	42
Existing Regulations Summary.....	46
N-C-L District.....	46
N-C-M District.....	47
Recent Trends	51



Valued qualitative aspects of neighborhood character include:

- Old charm and character of houses
- Friendly/neighborly sense of community
- Family/kid-friendly
- Modest homes
- Socioeconomic diversity
- Evident pride of ownership
- Diversity in ownership patterns
- One of a limited number of neighborhoods in town that does not have an HOA

Valued physical aspects of neighborhood character include:

- Walkability and bikability
- Proximity to amenities (including parks, schools, playgrounds, Old Town, trolley, CSU, etc.)
- Historic character and homes
- Integrity within blocks
- Wide streets
- Detached sidewalks
- Variety in lot types
- Alleys
- Front porches
- Views through lots
- Not all fenced
- Trees
- Relative low density
- Diversity of house style, age and scale
- Uniqueness of character among Fort Collins neighborhoods
- Less car-oriented design
- Orientation towards neighbors
- Houses designed with sustainability aspects already built into them (prior to car and air conditioning design)

Neighborhood Development Patterns

As a part of the Eastside and Westside Neighborhoods Character Study, a range of variables related to development patterns were analyzed in order to gain an understanding of the degree of consistency and the range of diversity that exists. When these variables are considered at a neighborhood-wide level, they yield an understanding of the general characteristics of the neighborhood. Then, when these variables are examined at a finer-grained degree, they suggest a series of smaller character areas, with shared characteristics.

Using this Information

The description of neighborhood development patterns and the features of the subordinate character areas is information that may be applied in these ways:

1. To inform an understanding of “context” for property owners planning improvements

This information may be included in a design handbook or guidelines, which could be provided for voluntary use. It would help property owners plan a project that takes the immediate setting into consideration.

2. To inform considerations of variances

The compatibility of a proposed improvement that requires a variance could be considered using the descriptions of key features from this analysis.

3. As a basis for applying revised development standards that are limited to certain contexts or subareas.

An individual tool might be focused on one or more specific character areas where this variable is particularly important to the sense of compatibility.



About the Maps Used in This Section

The maps included in this report cover a large area, and may be difficult to read at the size of the report page. In some cases, a detail of a portion of a map is provided to help convey the character of the development patterns. Large-scale copies of the maps can be found in "Appendix A: GIS Mapping Data".

The Eastside Neighborhood

Overall Development Patterns

The information that follows is derived from a series of maps illustrating the development patterns of the Eastside Neighborhood as a whole. They map information related to residential structures within the study area boundary. The information is extracted from the City's GIS system. (Data is as of June, 2012.)

Eastside General Observations

In general, while there is diversity throughout the neighborhood, there are narrow ranges of variation for some variables. Others occur as subarea contexts, which are discussed in the next section.

Eastside Neighborhood: Building Age

The Building Age map shows a pattern of development that begins in the northern portions of the neighborhood, and then builds out to the south and east. Note that building age in the GIS system tends to reflect the original building date, but may at times mean an “effective” building date, if, at a later stage, the property was significantly altered.

The oldest portions of the Eastside Neighborhood lie north of E. Myrtle Street and along Peterson, Whedbee and Smith Streets. The majority of the buildings in this area date from before 1930, with approximately 50% dating from before 1910. These areas filled in slowly between the 1890s and 1920s. Many block faces have a high degree of similarity in building age in this area.

The south and east portions of the neighborhood, near Circle and Eastdale Drives, developed in a much shorter period of time, in the 1950s and 1960s. These areas tend to have a higher degree of similarity in building features. Recent construction in the Eastside Neighborhood (the darkest blue color) is relatively sparse and is scattered throughout the neighborhood, but west of Stover Street.

Eastside Neighborhood: Building Age Map Detail

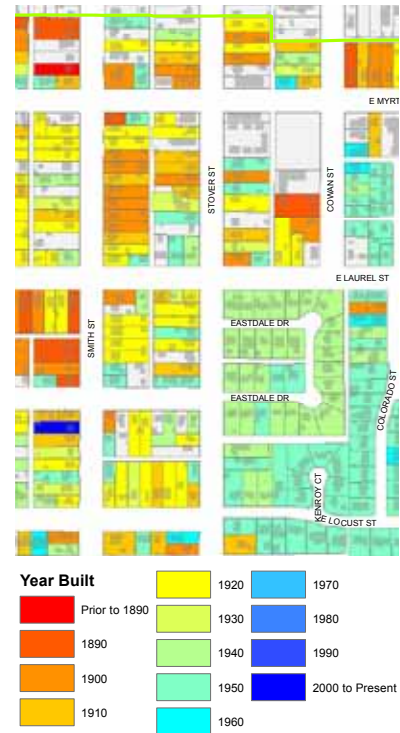

Eastside Neighborhood: Total Homes Built by Year Data

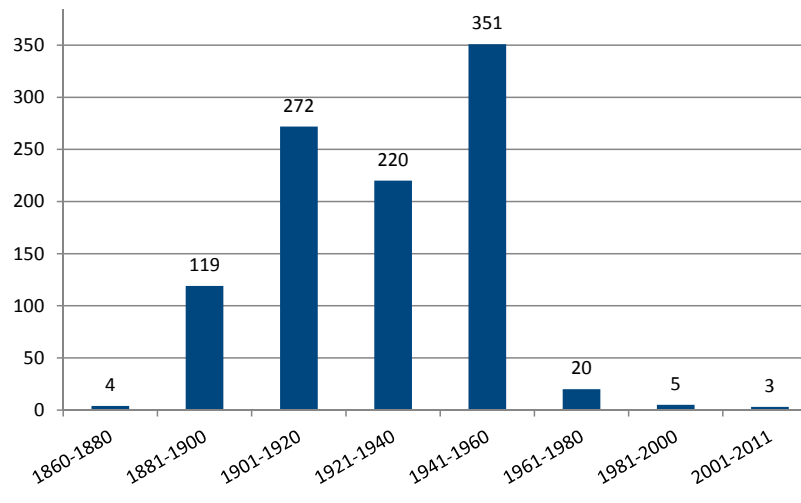

In the Eastside Neighborhood, the number of new buildings constructed has remained relatively low after construction peaked between 1941 and 1960.

The largest number of houses in the Eastside Neighborhood were built between 1941 and 1960 (shown in light green and teal). See the Appendix for a full map.

Eastside Neighborhood: Building Remodels

Eastside Neighborhood: Building Remodels Map Detail

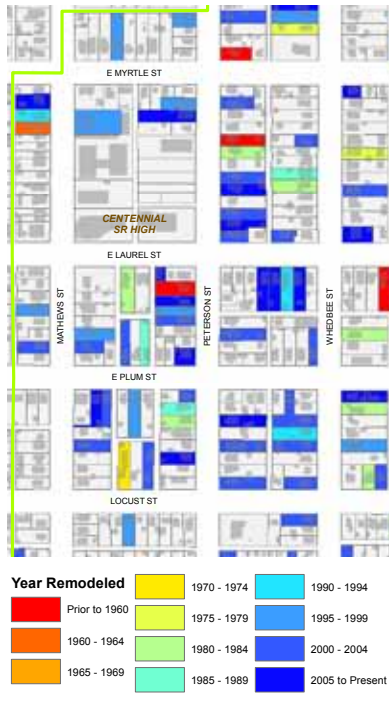

Building remodels in the Eastside Neighborhood are predominantly from between 2000–2009 (shown in dark blue). See the Appendix for a full map.

The Building Remodels map indicates when remodeling projects occurred, by decade increments. This information is from construction permit records, and therefore may not capture all alterations that property owners have made. A few remodels are documented from before 1980 through 1989, more remodels occurred during the mid-90s, and the majority of remodels were done after 2000. They are generally evenly distributed throughout the neighborhood.

Eastside Neighborhood: Total Building Remodels by Year Data

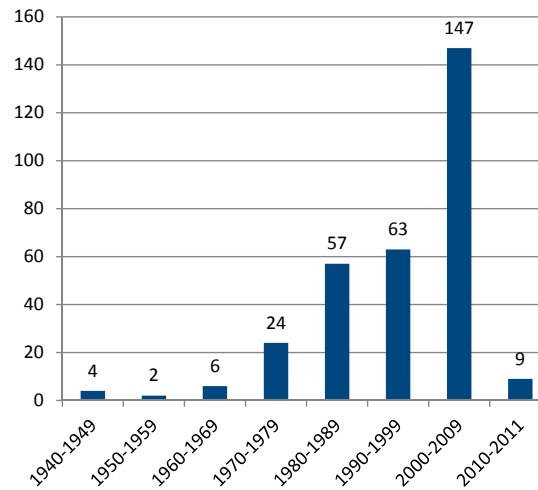

In the Eastside Neighborhood, the number of building remodels drastically increased over the last decade.

Eastside Neighborhood: House Size

House size, measured in square footage of floor area, appears in 500 square foot increments in this map. In the Eastside, the homes are predominantly 1,500 square feet or less. Of these, many are less than 1,000 square feet. However, there are several homes that are in the 2,000 square foot range. Only a few are 2,500 square feet or more. One noticeable concentration of these larger homes is along Elizabeth Street, east of Stover Street.

Eastside Neighborhood: House Size Data

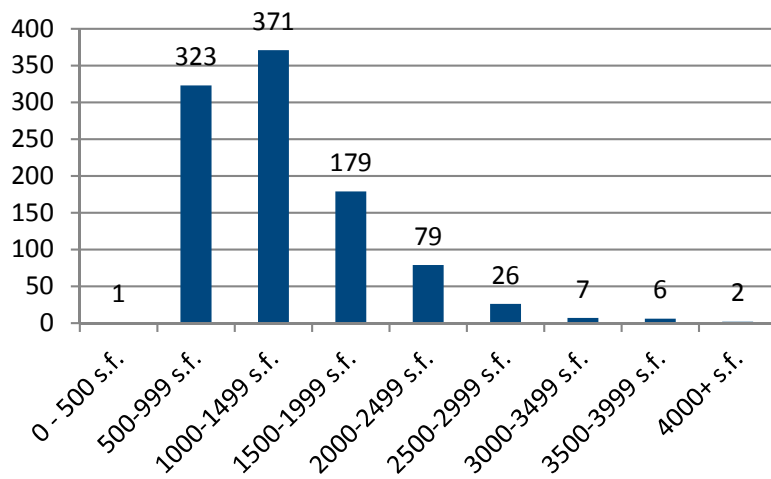

The majority of houses in the Eastside Neighborhood are 500 to 1,500 square feet, with relatively few homes over 2,000 square feet.

Eastside Neighborhood: House Size Map Detail

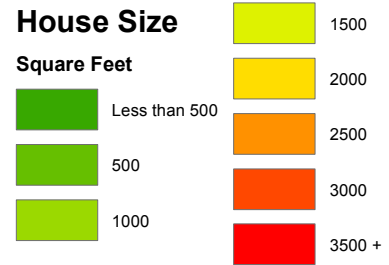

The majority of houses in the Eastside Neighborhood are 500 to 1,500 square feet (shown in green, light green and yellow). See the Appendix for a full map.

Eastside Neighborhood: Floor Area Ratio

Eastside Neighborhood: Floor Area Ratio Map Detail

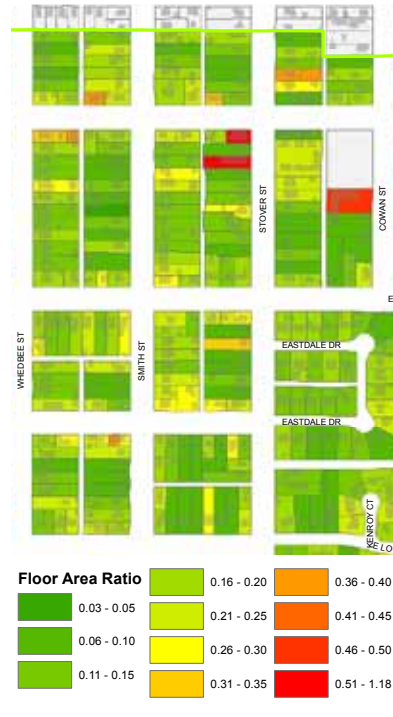

The majority of homes in the Eastside Neighborhood have a floor area ratio (FAR) of between 0.11 and 0.2 (shown in medium green). Very few houses have an FAR of 0.31 or greater (shown in orange and red). See the Appendix for a full map.

The proportion of house size to lot size is expressed as a Floor Area Ratio (FAR). On the Eastside, homes generally have an FAR of 0.25 or less. That is, a typical home has a floor area that is less than 25% of the land area of its lot. The next most frequently occurring FAR grouping is in the 0.26 - 0.30 range. These are scattered throughout the neighborhood, but occur less frequently along Elizabeth Street and in the southernmost portions of Stover Street.

Eastside Neighborhood: Floor Area Ratio Data

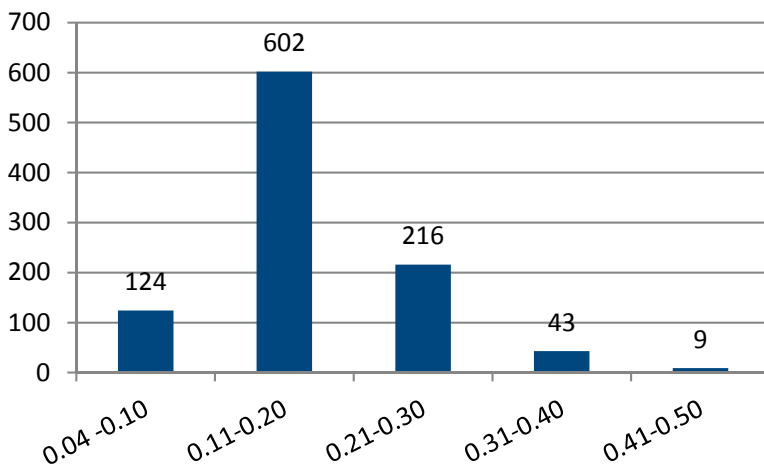

The majority of homes in the Eastside Neighborhood have a floor area ratio (FAR) of between 0.11 and 0.2. Relatively few homes have an FAR greater than 0.3.

Eastside Neighborhood: Building Height

The Building Height map shows the patterns of distribution of heights throughout the neighborhood. These are classified in full story and half-story increments. (A half-story is one in which the floor is partially contained within the roof form.) Throughout the neighborhood at large, the vast majority of homes are one story in height. However, there are several one-and-a-half story homes, as well as two-story homes, which are distributed rather widely throughout the area. Buildings above two stories are very rare.

Eastside Neighborhood: Building Height Data

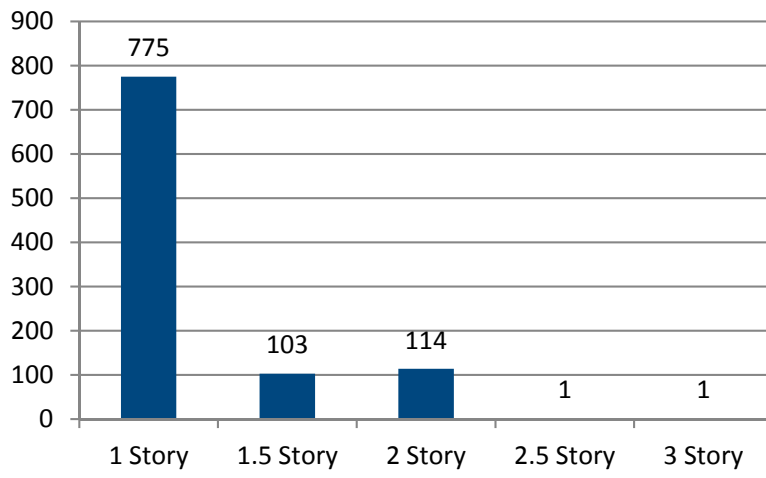

Building height in the Eastside Neighborhood is predominantly one story with relatively few one-and-a-half and two-story homes.

Eastside Neighborhood: Building Height Map Detail

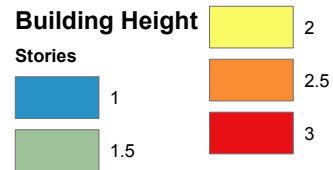
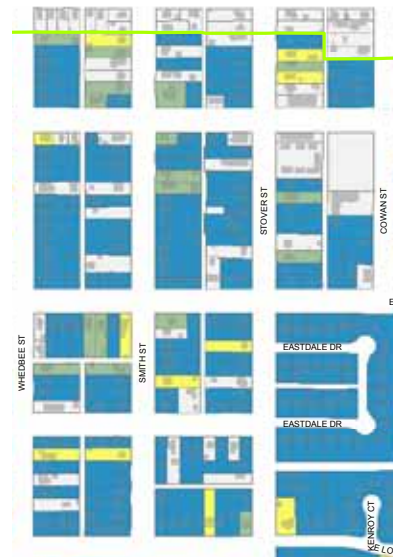

Building height in the Eastside Neighborhood is predominantly one-story (shown in dark blue). See the Appendix for a full map.

Eastside Neighborhood: Lot Size

Eastside Neighborhood: Lot Size Map Detail



25% of lots in the Eastside Neighborhood are between 9,000 and 9,999 square feet in size (shown in orange). See the Appendix for a full map.

The Lot Size map shows a distinct pattern in the distribution of lot sizes. Lot sizes are expressed in increments of 1,000 square feet. The largest group of properties are between 9,000 and 9,999 square feet. However, there are a substantial number of smaller lots in this area, often located at corners. Two concentrations of smaller lots are noteworthy: One lies between Smith and Mathews Streets, from Locust to Pitkin. Another is the Circle Drive area. There are other smaller concentrations, sometimes as only an individual block face, which exist along the eastern and western edges of the neighborhood.

Larger lots, those of 11,000 square feet or more, appear scattered in the northern parts of the neighborhood, and there are concentrations of these sizes along the southern boundaries.

Eastside Neighborhood: Percentage Distribution of Lot Size Data

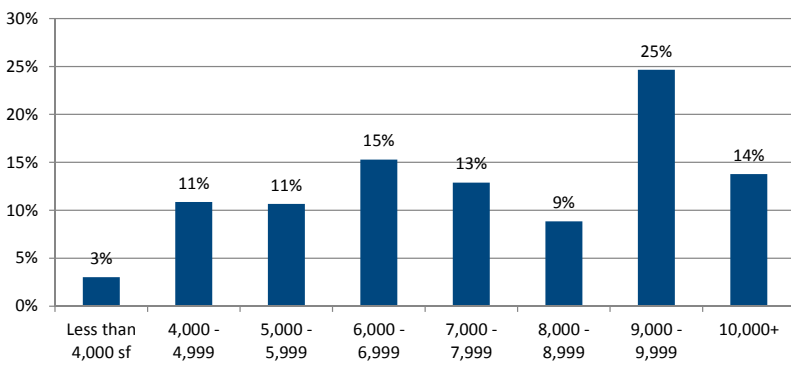

Lot size in the Eastside Neighborhood is fairly evenly distributed, with the majority of lots lower than 9,000 square feet and the greatest concentration of lots being between 9,000 and 9,999 square feet.

Eastside Neighborhood: Lot Frontage

The Lot Frontage map shows patterns in width of lots throughout the Eastside Neighborhood, in 50-foot increments. Combined with lot size, the frontage dimension determines the potential to be sub-divided. On the Eastside, the typical lot front width is 75 feet or less. Exceptions occur on corner lots, along curvilinear streets, and near E. Elizabeth Drive and Mathews Street, where larger lot width patterns occur.

**Eastside Neighborhood:
Lot Frontage Data**

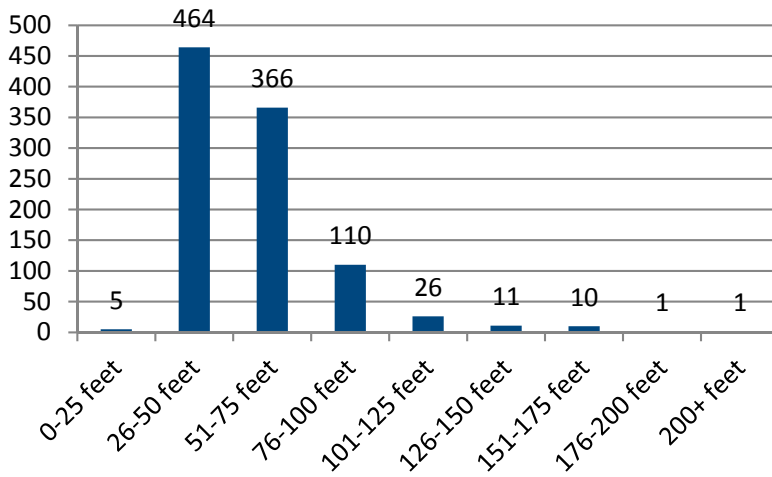

Lot frontages in the Eastside Neighborhood are predominantly less than 75 feet wide. A moderate number of lots are between 76 and 101 feet wide at the frontage, and relatively few are greater than 101 feet wide.

**Eastside Neighborhood:
Lot Frontage Map Detail**

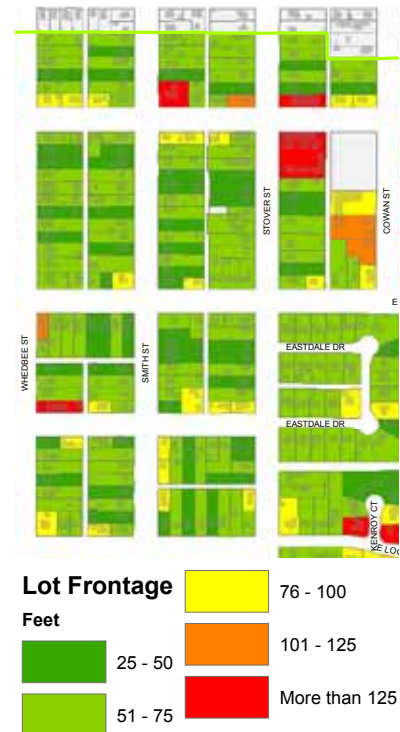

Lot frontages in the Eastside Neighborhood are predominantly less than 75 feet wide (shown in dark and light green). See the Appendix for a full map.

Eastside Neighborhood: Lot Coverage

Eastside Neighborhood: Lot Coverage Map Detail

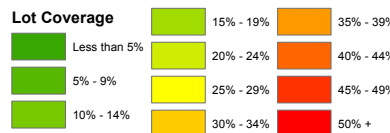
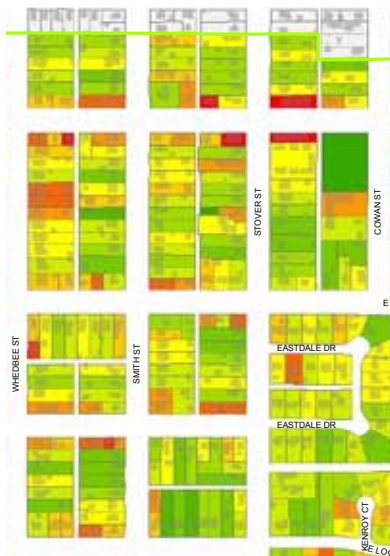

Lot coverage in the Eastside Neighborhood is predominantly between 11% and 30% (shown in green, light green and light yellow). See the Appendix for a full map.

The Lot Coverage map shows patterns in percentage of covered lot throughout the neighborhood. Lot coverage typically varies throughout each block on the Eastside. Most lots are between 11% and 30% covered.

Eastside Neighborhood: Lot Coverage Data

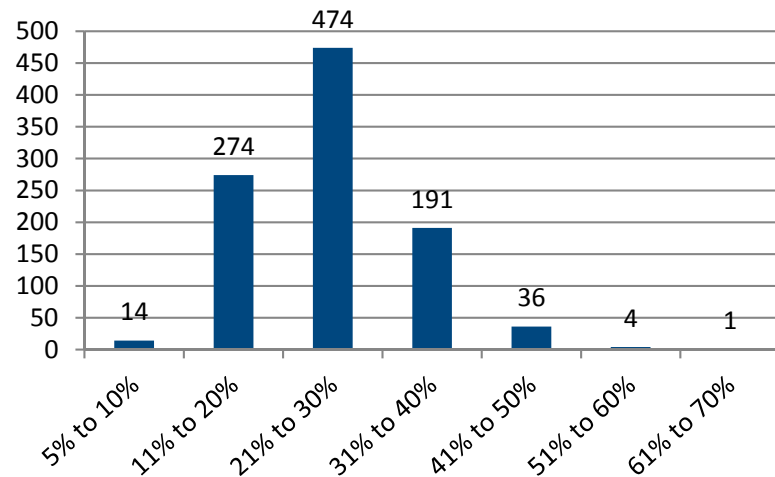

Lot coverage in the Eastside Neighborhood is predominantly between 11% and 30%. A moderate number of lots also have between 31% and 40% coverage, and relatively few have coverage of 41% or greater.

The Westside Neighborhood

Overall Development Patterns

The information that follows is derived from a series of maps illustrating the development patterns of the Westside Neighborhood as a whole. These show information related to residential structures within the study area boundary. The information is extracted from the City's GIS system. (Data is as of June, 2012.)



General Observations for the Westside Neighborhood

While variation and diversity in building and development patterns exist throughout the Westside Neighborhood, this typically occurs within a focused range of variation. In addition, several specific areas also consistently vary from each other, occurring as subarea contexts, which are discussed in the following section.

Westside Neighborhood: Building Age

Westside Neighborhood: Building Age Map Detail

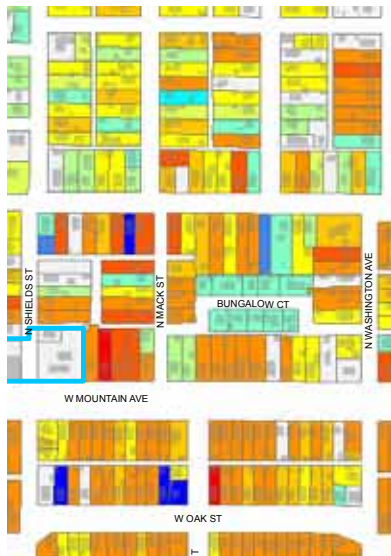

In the Westside Neighborhood, home construction was at its highest points from 1901 to 1920 (shown in orange, light orange and yellow), and from 1941 to 1960 (shown in light green, teal and light blue). See the Appendix for a full map.

The Building Age map shows patterns in construction throughout the history of the neighborhood. In the Westside, the oldest areas spread out along W. Mountain Avenue and the areas closest to downtown. These areas filled in slowly between the 1890s and the 1920s. This time period was the first of two major periods of construction in the neighborhood.

The second major period of construction occurred between the 1940s and the 1960s. During this time areas of the edges of the neighborhood furthest from downtown developed in shorter time periods leading to less variety in building types in these areas.

Recent construction is scattered throughout the neighborhood and most lots are within a four-block radius of recent construction.

Westside Neighborhood: Total Homes Built by Year Data

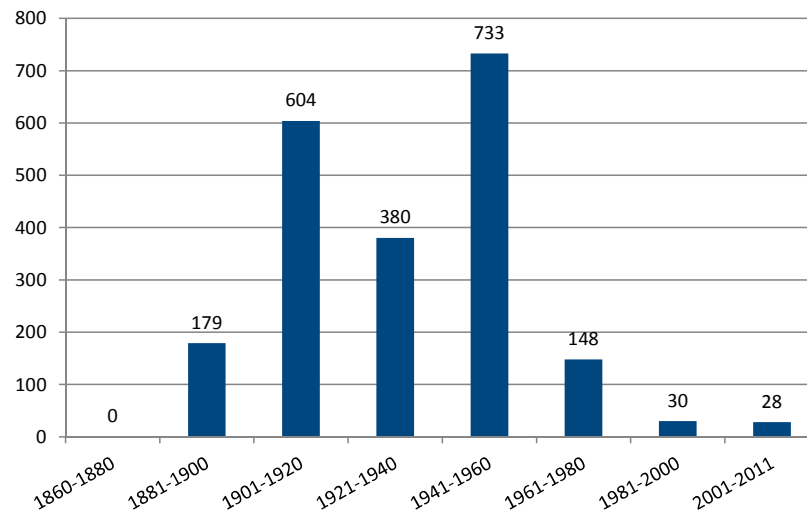

In the Westside Neighborhood, home construction was at its highest points from 1901 to 1920, and from 1941 to 1960. Note that between 2001 and 2011, nearly as many new homes were built as in the previous two decades combined (1981-2000).

Westside Neighborhood: Building Remodels

The Building Remodels map shows the years in which remodels of homes have occurred. This information is from construction permit records, and therefore may not capture all alterations that property owners have made.

Remodels have occurred throughout the history of the Westside Neighborhood. However, the pace of remodels increased over the 1980s and 1990s and the vast majority of remodels have occurred since 2000. Recent remodels occurred throughout the neighborhood, but are also heavily concentrated along and near W. Mountain Avenue.

Westside Neighborhood: Total Building Remodels by Year Data

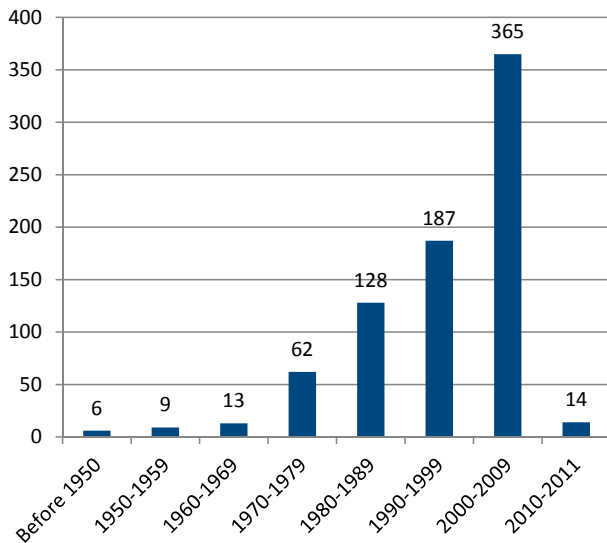

In the Westside Neighborhood, the number of building remodels steadily grew and then significantly increased over the last decade.

Westside Neighborhood: Building Remodels Map Detail

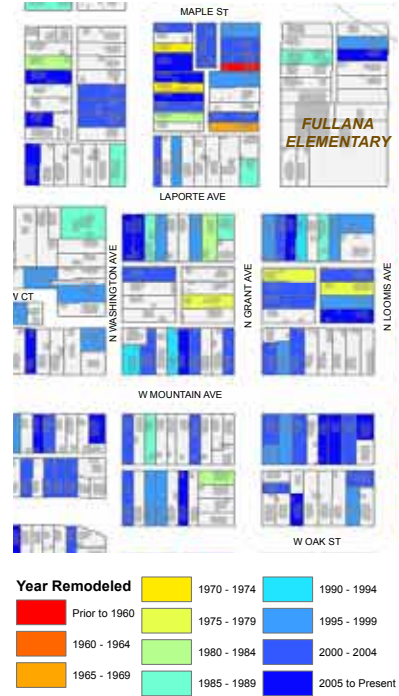

In the Westside Neighborhood, the number of building remodels significantly increased over the last decade (shown in dark blue). See the Appendix for a full map.

Westside Neighborhood: Single Family House Size

Westside Neighborhood: House Size Map Detail

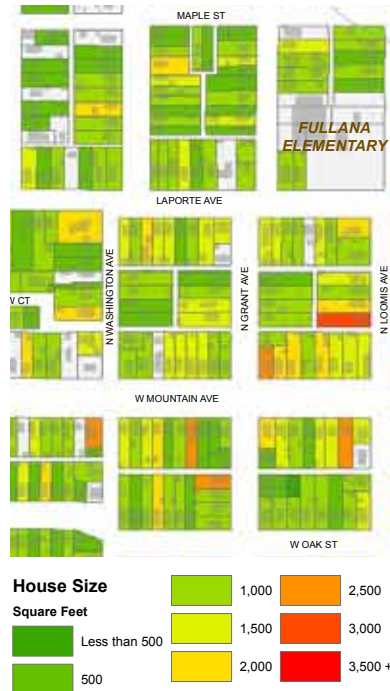

The majority of houses in the Westside Neighborhood are 500 to 1,500 square feet (shown in green and light green). See the Appendix for a full map.

The House Size map shows patterns in the size of homes throughout the neighborhood. In the Westside, homes are predominantly between 500 and 1,500 square feet, with relatively few homes over 2,000 square feet. In most areas, the size of homes tends to remain fairly consistent across an individual block, but can vary between blocks. However, along W. Mountain Avenue the average house size is larger and varies more across an individual block.

Westside Neighborhood: House Size Data

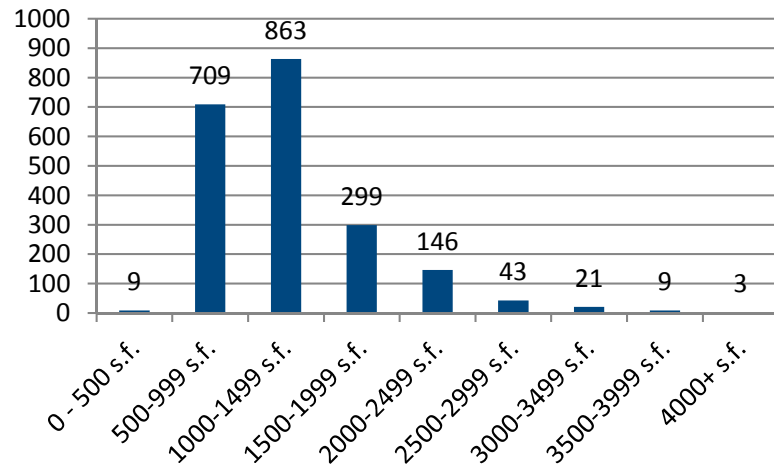

The majority of houses in the Westside Neighborhood are 500 to 1,500 square feet, with relatively few homes over 2,000 square feet.

Westside Neighborhood: Floor Area Ratio (FAR)

The Floor Area Ratio map shows patterns in the relationship of home sizes to lot sizes throughout the neighborhood. The proportion of house size to lot size is expressed as a Floor Area Ratio (FAR). In the Westside, homes predominantly have an FAR of 0.30 or less. That is, a typical home has a floor area that is less than 30% of the land area of its lot. A few houses with higher FARs are scattered throughout the neighborhood. Along and near W. Mountain Avenue, FARs are also larger and can vary widely across an individual block.

Westside Neighborhood: Floor Area Ratio Data

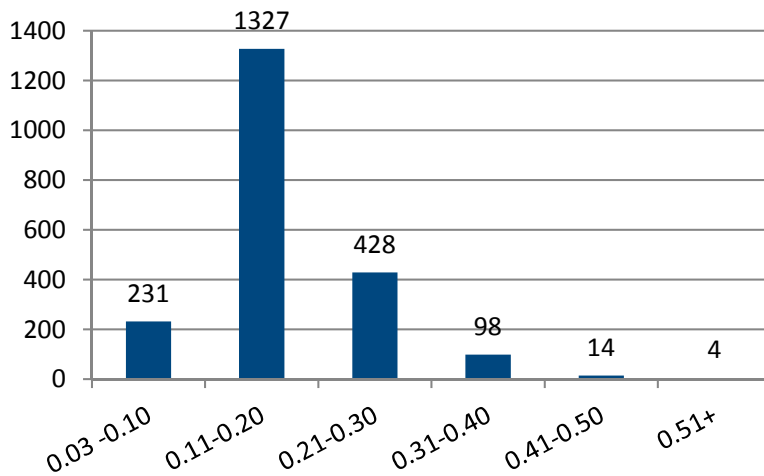

The majority of homes in the Westside Neighborhood have a floor area ratio (FAR) of between 0.11 and 0.2. Relatively few homes have an FAR greater than 0.3.

Westside Neighborhood: Floor Area Ratio Map Detail

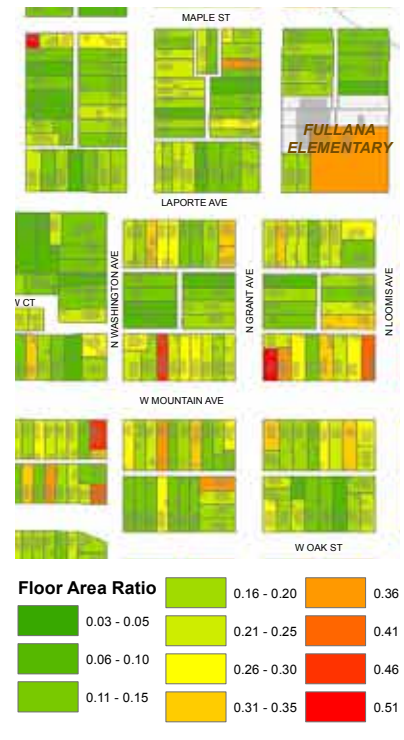

The majority of houses in the Westside Neighborhood have a floor area ratio (FAR) of between 0.11 and 0.2 (shown in green, light green and yellow). See the Appendix for a full map.

Westside Neighborhood: Building Height

Westside Neighborhood: Building Height Map Detail

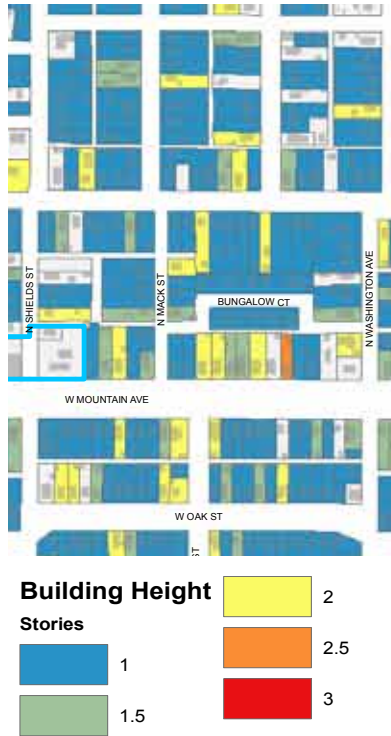

Building heights in the Westside Neighborhood are predominantly one story (shown in blue). See the Appendix for a full map.

The Building Height map shows patterns of distribution of heights throughout the neighborhood. These are classified in full-story and half-story increments. (A half story is one in which the floor is partially contained within the roof form.)

In the Westside Neighborhood, homes are predominantly one story. Roughly equal numbers of one-and-a-half and two story houses can also be found dispersed throughout the neighborhood. Concentrations of taller homes occur along and near W. Mountain Avenue as well as in a sub-development at the northern edge of the neighborhood on Hanna Street.

Westside Neighborhood: Building Height Data

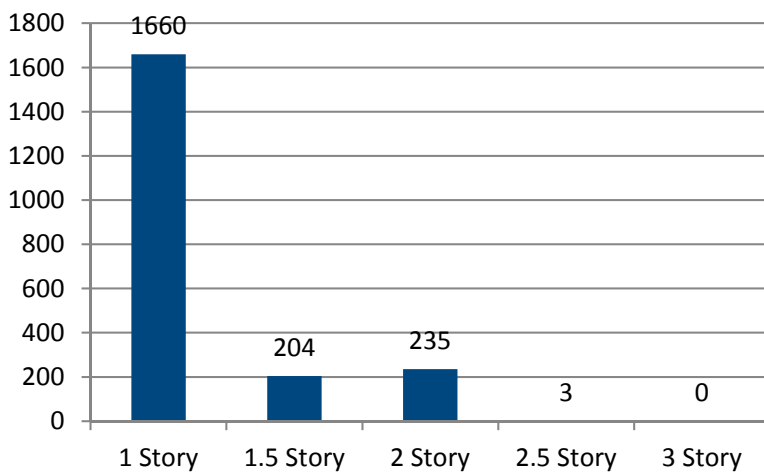

Building heights in the Westside Neighborhood are predominantly one story with roughly equal numbers of one-and-a-half and two-story homes.

Westside Neighborhood: Lot Size

The Lot Size map shows patterns in square footage of lots throughout the neighborhood. In the Westside Neighborhood, most blocks have a predominant lot size, but lot size varies from block to block. More variety in lot size within a block occurs in areas with curvilinear street patterns and where there are smaller or subdivided corner lots. Areas with H-shaped alleys will also have a large range in lot sizes, typically with several larger lots along a block of smaller lots. More variety in lot size also occurs along W. Mountain Avenue, though several individual blocks remain consistent.

Westside Neighborhood: Percentage Distribution of Lot Size Data

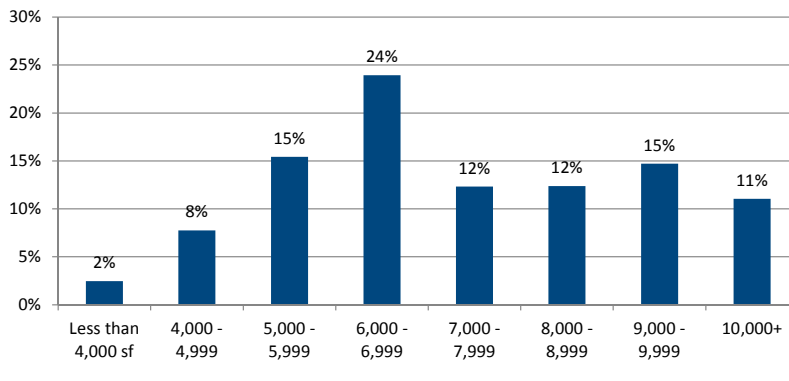

Lot size in the Westside Neighborhood is fairly evenly distributed, with greater percentages of lots sized between 6,000 and 6,999 square feet, and lower percentages of lots sized smaller than 5,000 square feet.

Westside Neighborhood: Lot Size Map Detail

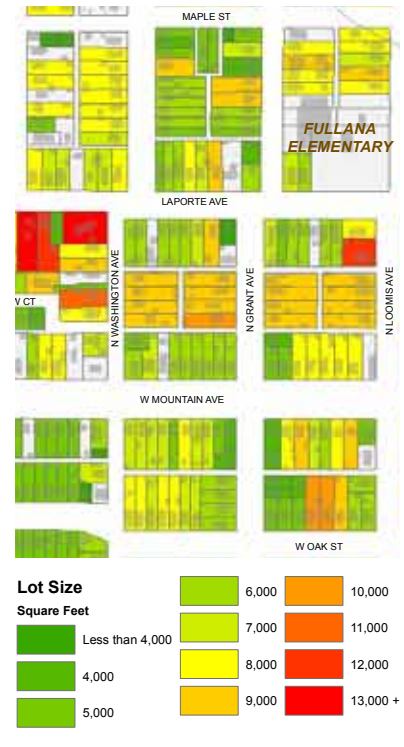

Lot size in the Westside Neighborhood is fairly evenly distributed, with greater percentages of lots (24%) sized between 6,000 and 6,999 square feet, and lower percentages of lots sized smaller than 5,000 square feet (shown in light green). See the Appendix for a full map.

**Westside Neighborhood:
Lot Frontage Map Detail**

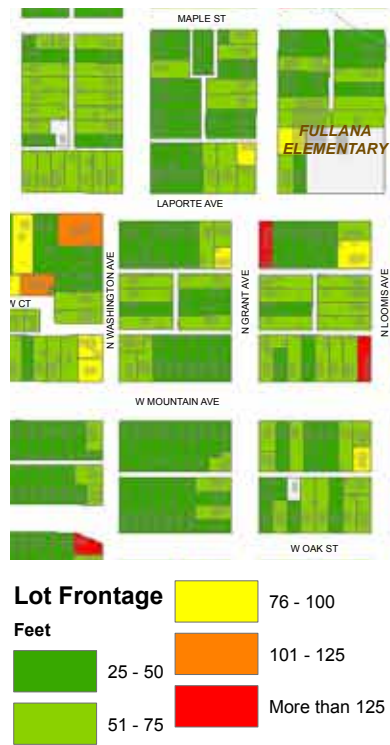

Lot frontages in the Westside Neighborhood are predominantly less than 75 feet wide (shown in green, and light green). See the Appendix for a full map.

Westside Neighborhood: Lot Frontage

The Lot Frontage map shows patterns in width of lots throughout the neighborhood. Combined with lot size, the frontage helps determine if a lot may legally be subdivided. In the Westside Neighborhood, lot frontage is typically 75 feet or less, with some limited areas of slightly wider lots. Exceptions occur on corner lots, along curvilinear streets, and where H-shaped alleys occur. Several areas along W. Mountain Avenue also differ, having a much narrower lot frontage than the neighborhood's average.

**Westside Neighborhood:
Lot Frontage Data**

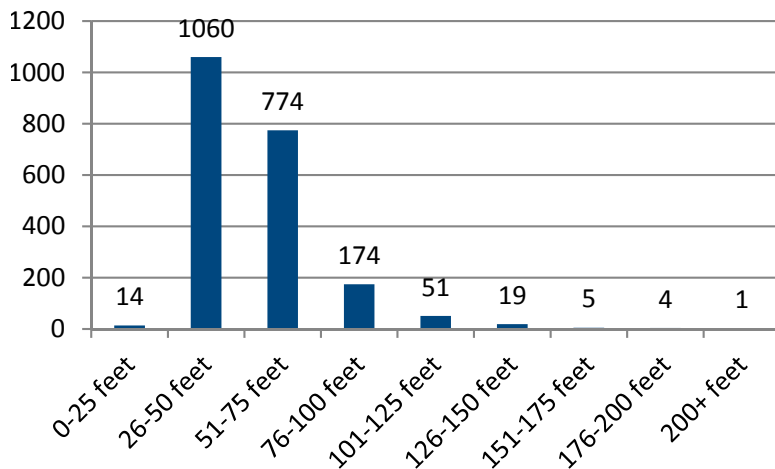

Lot frontages in the Westside Neighborhood are predominantly less than 75 feet wide. A limited number of lots are between 76 and 101 feet wide at the frontage, and relatively few are greater than 101 feet wide.

Westside Neighborhood: Lot Coverage

The Lot Coverage map shows patterns in percentage of covered lot throughout the neighborhood. Lot coverage typically varies throughout each block in the Westside Neighborhood. Most lots are less than 50% covered. Blocks along W. Mountain Avenue and those developed in the 1950s, 1960s and 1970s have a higher average lot coverage than is typical of the rest of the neighborhood.

Westside Neighborhood: Lot Coverage Data

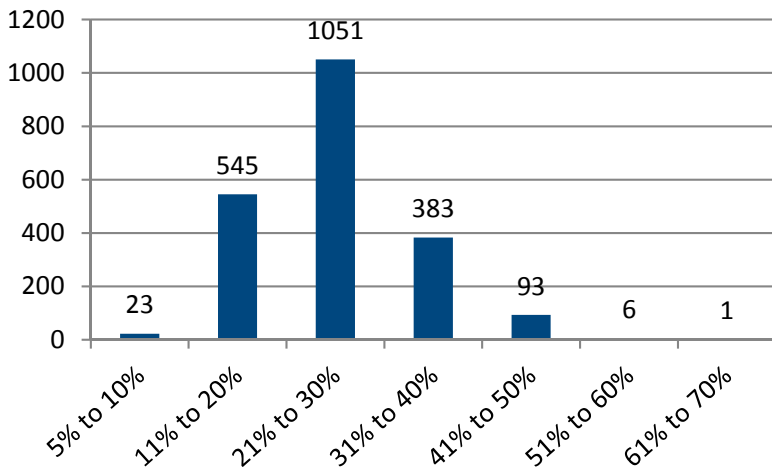

Lot coverage in the Westside Neighborhood is predominantly between 11% and 40%. A moderate number of lots also have between 41% and 50% coverage, and very few have coverage of less than 11% or greater than 50%.

Westside Neighborhood: Lot Coverage Map Detail

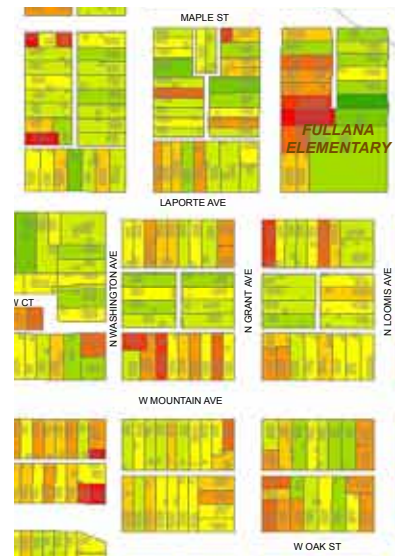

Lot Coverage

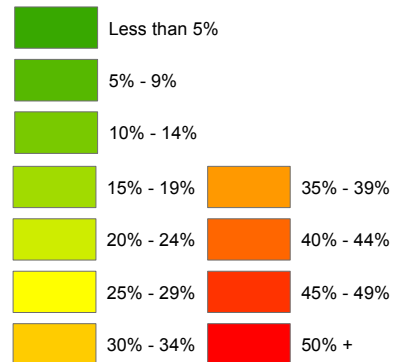

Lot coverage in the Westside Neighborhood is predominantly between 11% and 40% (shown in green, light green, yellow and orange). See the Appendix for a full map.

Character Areas

While the Eastside and Westside Neighborhoods exhibit many features that may be considered universal, there are in fact distinct differences in development patterns that exist in individual subareas. These differences contribute to the perceived sense of diversity that is often mentioned when describing these neighborhoods. These differing characteristics are important to consider when developing a design for new construction that will be compatible with its context.

Some areas, for example, have a very consistent range of building sizes, or a uniform range of lot coverage percentages. In other places, diversity exists, but nonetheless within a defined range. Other variables, including building height, floor area ratio, lot size and building age contribute to the differing contexts.

Those variables were considered in setting forth the different character areas that are described in this section. A total of six distinct character area types are defined. These areas occur multiple times in both the Eastside and the Westside Neighborhoods. Each area has a unique combination of variables, but it also shares several similarities with at least one (and often more) of the other character areas.

Using The Character Areas

The character areas can help to inform discussions about existing context, which is a key consideration in designing improvements that will retain and enhance the unique character and context of the neighborhoods as they continue to change. They may serve as the foundation for an informational design handbook that property owners could use in developing design concepts for additions and infill. They also could be used in considering the appropriateness of allowing variances from existing development standards, or in determining how any potential refinements to development regulations might be tailored to settings with special sensitivity.

About the Character Area Boundaries

The maps that identify the location of the character areas uses a hard line, which follows the edges of streets, alleys and property lines. But these boundaries may in some cases be more “fuzzy,” where transitions in character occur. In this sense, the boundaries help to define general concentrations of distinctive characteristics, but should not be considered to be definite, in contrast to zoning boundary lines. See page 44 for maps of the character area boundaries. Full size maps can also be found in "Appendix B: Character Area Maps"

Character Area Summary

	Character Area 1	Character Area 2	Character Area 3	Character Area 4	Character Area 5	Character Area 6
Distribution of Properties Within Character Areas						
Total Properties	11%	24%	4%	36%	5%	19%
Lot Size						
Typical Range	Varies	Varies	4,000 – 5,999 sf	Varies	4,000 – 6,999 sf	6,000 – 6,999 sf
4,000 sf or less	7%	6%	5%	6%	4%	1%
4,000–4,999 sf	9%	10%	26%	7%	12%	1%
5,000–5,999 sf	8%	20%	12%	12%	24%	8%
6,000–6,999 sf	15%	13%	5%	12%	17%	43%
7,000–7,999 sf	12%	14%	3%	13%	10%	14%
8,000–8,999 sf	10%	6%	0%	15%	11%	10%
9,000–9,999 sf	28%	25%	2%	17%	12%	6%
10,000 sf or more	11%	5%	1%	16%	10%	11%
Average	8,020 sf	7,285 sf	6,540 sf	8,590 sf	7,085 sf	7,385 sf
Lot Width						
Typical Range	26–75'	26–75'	26–50'	26–75'	26–75'	51–75'
25' or less	2%	15%	3%	3%	2%	1%
26'–50'	52%	61%	75%	45%	36%	13%
51'–75'	33%	28%	17%	35%	45%	68%
76–100'	3%	6%	1%	11%	11%	14%
101' +	7%	3%	5%	6%	6%	4%
Average	57 feet	53 feet	48 feet	60 feet	60 feet	65 feet
Lot Coverage						
Typical Range	11–40%	11–40%	11–30%	11–30%	11–30%	21–30%
0–10%	1%	3%	3%	7%	7%	2%
11–20%	23%	22%	28%	31%	28%	22%
21–30%	45%	45%	53%	41%	49%	58%
31–40%	21%	23%	12%	17%	15%	16%
40% +	10%	7%	4%	5%	4%	2%
Average	27%	27%	24%	24%	25%	25%

Character Area Summary

	Character Area 1	Character Area 2	Character Area 3	Character Area 4	Character Area 5	Character Area 6
Year Built						
Typical Range	1882–1920	1901–1920	1881–1920	1901–1960	1941–1960	1941–1960
Average	1912	1916	1914	1934	1951	1956
Year Remodeled						
Typical Range	2000–2009	2000–2009	1980–2009	2000–2009	1990–2009	1970–2009
Percent Remodeled	51%	39%	45%	34%	30%	24%
Building Size						
Typical Range	500 – 2,499 sf	500 – 1,499 sf	500 – 999 sf	500 – 1,499 sf	500 – 1,499 sf	1,000 – 1,499 sf
999 sf or less	14%	37%	69%	40%	43%	26%
1,000 – 1,499 sf	35%	40%	27%	34%	40%	56%
1,500 – 1,999 sf	23%	16%	3%	13%	14%	14%
2,000 – 2,499 sf	18%	5%	1%	9%	2%	3%
2,500 sf or greater	10%	1%	–	3%	3%	4%
Average	1,670 sf	1,220 sf	895 sf	1,280 sf	1,148 sf	1,225 sf
Building Height						
Typical Range	1–2 stories	1–1.5 stories	1 story	1–2 stories	1 story	1 story
1 story	48%	79%	93%	78%	90%	91%
1.5 story	25%	13%	4%	10%	5%	1%
2 story	25%	9%	2%	12%	5%	8%
2.5 story	1%	–	–	0%	–	–
Floor Area Ratio (FAR)						
Typical Range	0.4 or less	0.3 or less	0.11–0.2	0.3 or less	0.3 or less	0.11–0.2
0.0–0.11	8%	12%	13%	11%	11%	8%
0.11–0.2	42%	56%	72%	54%	63%	78%
0.21–0.3	32%	24%	11%	20%	24%	13%
0.31–0.4	14%	6%	5%	5%	1%	1%
0.4 +	5%	2%	–	1%	1%	–
Average	0.22	0.19	0.16	0.17	0.17	0.16

Character Area 1: Key Features

- Homes typically date from 1882–1920.
 - Richly-detailed homes with large front porches
 - Building scale and style are typically consistent within individual blocks.
 - Variety in home scales, with largest typical building size (height and square footage)
 - 1-, 1.5- and 2-story homes typical
 - Large variety in lot sizes with largest typical lot size overall
-

Character Area 1

This character area includes portions of the neighborhoods with richly-detailed homes that are somewhat larger in scale than those found in other parts of the Eastside and Westside Neighborhoods. Much of the portion of Mountain Avenue that is close to Old Town is an example.

Site Plan Features

In many of these areas, building fronts align with uniform front yard setbacks. This establishes a prominent street wall. Lawns are predominant. Fences or site walls occur infrequently, and are relatively low in scale. Lot sizes vary between blocks, but are more consistent within an individual block face.

Building Scale Features

Just less than half of homes are one story. Many primary structures are also one-and-a-half stories with the upper floors expressed with dormer windows, or are a full two stories. A typical house has a substantial, one-story front porch, which when aligned with others along the block, establishes a consistent sense of scale, even when the overall building heights vary. Building sizes vary widely.

Architectural Features

- Most homes have sloping roof forms, in a mix of gable and hip shapes.
- A combination of brick and wood siding. Many homes include both materials.
- Front entries are defined with porches, and these are relatively large and in proportion to the building.
- Trim details with contrasting colors add a sense of scale and provide visual interest.
- As some of the earliest parts of the neighborhoods, a general consistency exists in building age (typically before 1920).



These homes are located in Character Area 1.



Character Area 1 includes portions of the neighborhoods with richly-detailed homes that are somewhat larger in scale than those found in other parts of the Eastside and Westside Neighborhoods.

Character Area 2: Key Features

- Homes typically date from 1901–1920.
 - Home have a moderate to high degree of architectural details.
 - Building scale and style are typically consistent within individual blocks.
 - Front entries are defined with large porches.
 - Home and lot sizes are in a “middle” range, with respect to the neighborhoods as a whole.
 - 1–1.5 story homes typical
-

Character Area 2

Most of the homes in this character area were built prior to 1940, and their sizes are in a “middle” range with respect to the Eastside and Westside Neighborhoods as a whole. Homes exhibit a moderate to high degree of architectural details, which contribute to a sense of scale. Building and lot characteristics can vary within each area. However, individual blocks are more consistent. Some larger-scale homes are located on corner lots in these areas.

Character Area 2 is similar to Character Area 4, but with a greater level of consistency in building styles and lot and building sizes.

Site Plan Features

In many of these areas, building fronts align, with uniform front yard setbacks; this establishes a prominent street wall. Lawns are predominant. Fences or site walls occur infrequently, and are relatively low in scale. Lot sizes and widths are in a “middle” range, with respect to the Eastside and Westside Neighborhoods as a whole.

Building Scale Features

Many primary structures are one- to one-and-a-half stories with the upper floors expressed with dormer windows. A small percentage are a full two stories. A typical house has a substantial one-story front porch, which when aligned with others along the block, establishes a consistent sense of scale, even when the overall building heights vary.

Architectural Features

- Most homes have sloping roof forms, in a mix of gable and hip shapes.
- A combination of brick and wood siding. Many homes include both materials.
- Front entries are defined with porches, and these are relatively large and in proportion to the building.
- A general consistency exists in building age before 1940. (Many are between 1901 and 1920.)



These homes are located in Character Area 2.



Most homes in Character Area 2 were built prior to 1945, and are in the “middle” range of building size with respect to the Eastside and Westside Neighborhoods at large.

Character Area 3: Key Features

- Homes typically date from 1881–1920.
 - Architectural details are more limited but help establish a sense of human scale.
 - Building scale and style are typically consistent within individual blocks.
 - Front entries are defined with moderate porches.
 - Home and lot sizes are in a “middle” range, with respect to the neighborhoods as a whole.
 - One story homes predominate.
-

Character Area 3

This character area includes homes with the lowest typical building scale. These are generally small pockets of development with very distinct character. Architectural details are more limited than in other areas, though they still help establish a sense of human scale. Homes appear consistent in character and size across one or more block faces. The majority of homes in these areas are predominantly one story, with a limited number of one-and-a-half and two-story structures.

Site Plan Features

In many of these areas, front yards are similar in depth and building fronts generally align. This establishes a prominent street wall. Lawns are predominant. Fences or site walls occur infrequently, and are relatively low in scale. Lot sizes are small relative to the Eastside and Westside Neighborhoods as a whole.

Building Scale Features

Many primary structures are one story. A limited number are one-and-a-half stories with the upper floors expressed with dormer windows. A typical house has a moderate, one-story front porch, which when aligned with others along the block, establishes a consistent sense of scale. Home size is small relative to the Eastside and Westside Neighborhoods as a whole.

Architectural Features

- Most homes have sloping roof forms, in a mix of gable and hip shapes.
- A combination of brick and wood siding. Many homes include both materials.
- Front entries are defined with moderate porches in proportion to the building front.
- Building age is varied within a narrow range (1881–1920).
- There have been few remodels in this area; architectural character is consistent throughout.



These homes are located in Character Area 3.

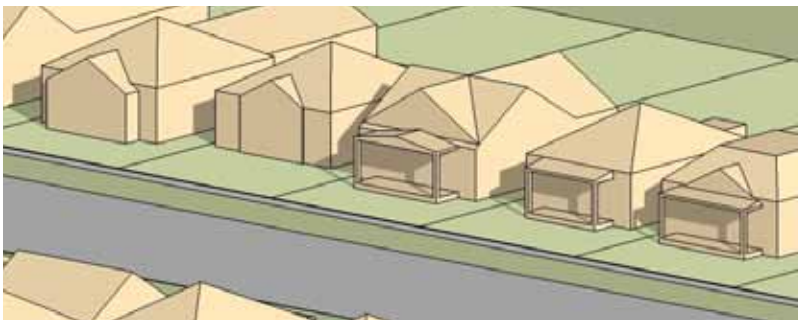

A typical house in Character Area 3 has a moderate, one-story front porch, which when aligned with others along the block, establishes a consistent sense of scale.

Character Area 4: Key Features

- Homes typically date from 1901–1960.
- Homes have a moderate to high degree of architectural details.
- Front entries are defined with moderate porches
- Building scale is typically consistent within individual blocks.
- Building style varies widely within individual blocks.
- Home and lot sizes are small with respect to the neighborhoods as a whole.
- One-story homes predominate, 1.5 and 2 story homes are also typical

Character Area 4

In these areas there is no dominant style, rather the full variety of development in the neighborhoods is represented. Homes date from early development of the neighborhood through to the mid-twentieth century. There is a large variety in building style and form across individual blocks in these areas. However, the homes are all of a similar scale with a moderate level of detailing. These areas have a greater degree of diversity, in terms of building age, scale and architectural styles and character than others. This character area category includes large portions of both the Eastside and Westside Neighborhoods.

These areas are similar in scale to those of Character Area 2, but with a much greater diversity in lot and building characteristics and house styles.

Site Plan Features

In many of these areas, building fronts align, with uniform front yard setbacks. This establishes a prominent street wall. Lawns are predominant. Fences or site walls occur infrequently, and are relatively low in scale.

Building Scale Features

The majority of homes are one story. A small percentage of primary structures are also one-and-a-half stories, with the upper floors expressed with dormer windows, or they are a full two stories. Building sizes are in a “middle” range, with respect to the Eastside and Westside Neighborhoods as a whole.

Architectural Features

- Most homes have sloping roof forms, in a mix of gable and hip shapes.
- Primarily frame construction.
- Front entries are defined with porches in proportion to the building.
- More diversity in character; built throughout 1901–1960.



These homes are located in Character Area 4.

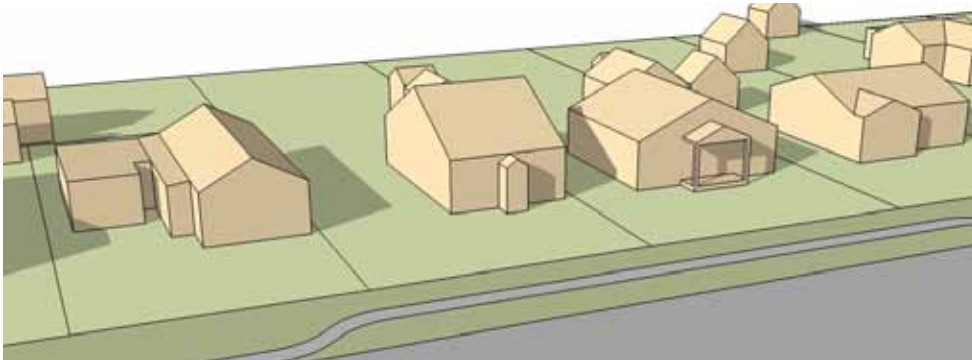

There is a large variety in building style and form across individual blocks in Character Area 4.

Character Area 5: Key Features

- Homes typically date from 1941–1960.
 - Architectural details are more limited but help establish a sense of human scale.
 - Building scale is typically consistent within individual blocks.
 - Front entries are defined with small porches or landings.
 - Home and lot sizes are small to middle range, with respect to the neighborhoods as a whole.
 - One-story homes predominate
-

Character Area 5

This character area represents the post-war home styles built in areas with older lot and block patterns. Homes are typically one story, with minimal detailing. Due to older lot shapes being narrow and deep, homes tend to be rectangular with street-facing front-gable roofs. These areas exhibit a relatively high degree of consistency in overall development patterns and building characteristics. These are small, distinct enclaves.

These areas are similar in to scale to Areas 2 and 4, but have distinct building patterns and styles unique to the time period they were built.

Site Plan Features

In many of these areas, building fronts align, with uniform front yard setbacks. This establishes a prominent street wall. Lawns are predominant. Fences or site walls occur infrequently, and are relatively low in scale.

Building Scale Features

Most primary structures are one story. A typical house has a moderate one-story front porch or stoop. Building fronts align with others along the block, establishing a consistent sense of scale.

Architectural Features

- Most homes have low sloping roof forms, in a mix of gable and hip shapes.
- A combination of brick and wood siding. Many homes include both materials.
- Front entries are defined with porches or landings which are relatively small in proportion to the building.
- A high level of consistency exists in building age (predominantly between 1941 and 1960).



These homes are located in Character Area 5.

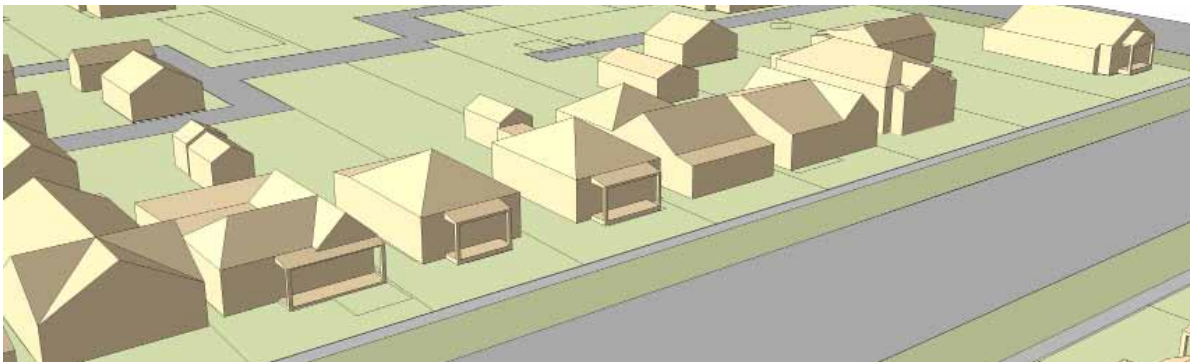

Character Area 5 includes primarily one-story post-war home styles on narrow, deep lots.

Character Area 6: Key Features

- Homes typically date from 1941–1960.
 - Architectural details are limited.
 - Building scale is typically consistent within individual blocks.
 - Front entries are defined with small landings.
 - Home and lot sizes are in a “middle” range, with respect to the neighborhoods as a whole.
 - Lot widths are largest relative to the neighborhoods as a whole.
 - One-story homes predominate
-

Character Area 6

This character area includes the mid-century modern subdivisions. Ranch style homes predominate, typically with limited, simple detailing, and rectangular forms with shallow roofs running parallel to the street. Houses are predominately one story in height, with a few split-level homes, and are low to medium scale. Street patterns include cul-de-sacs and curvilinear layouts, with no alleys and wide, shallow lots.

Site Plan Features

In many of these areas, building fronts align, with uniform front yard setbacks. This establishes a prominent street wall. Lawns are predominant. Fences or site walls occur infrequently, and are relatively low in scale.

Building Scale Features

Many primary structures are one story, others are split-level or a full two-story height. A typical house has a moderate stoop but typically does not have a porch. Building fronts align with others along the block, establishing a consistent sense of scale. Many buildings in these areas have been remodeled.

Architectural Features:

- Most homes have low sloping roof forms, in a mix of gable and hip shapes.
- A combination of brick and wood siding. Many homes include both materials.
- Front entries are defined with landings, and these are relatively small in proportion to the building.
- Very consistent in building age (typically between 1950 and 1970).



These homes are located in Character Area 6.

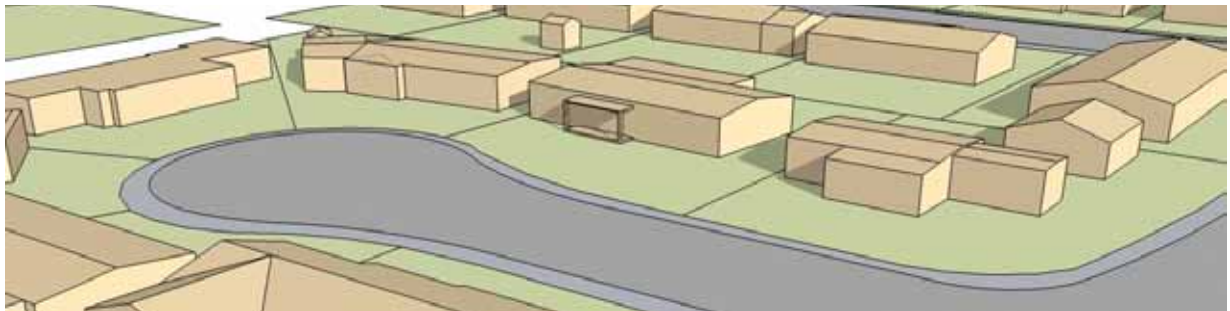

Ranch style homes predominate in Character Area 6, typically having limited, simple detailing, and rectangular forms with shallow roofs running parallel to the street.

Eastside and Westside Neighborhoods Character Study

Draft Character Areas - Eastside Neighborhood

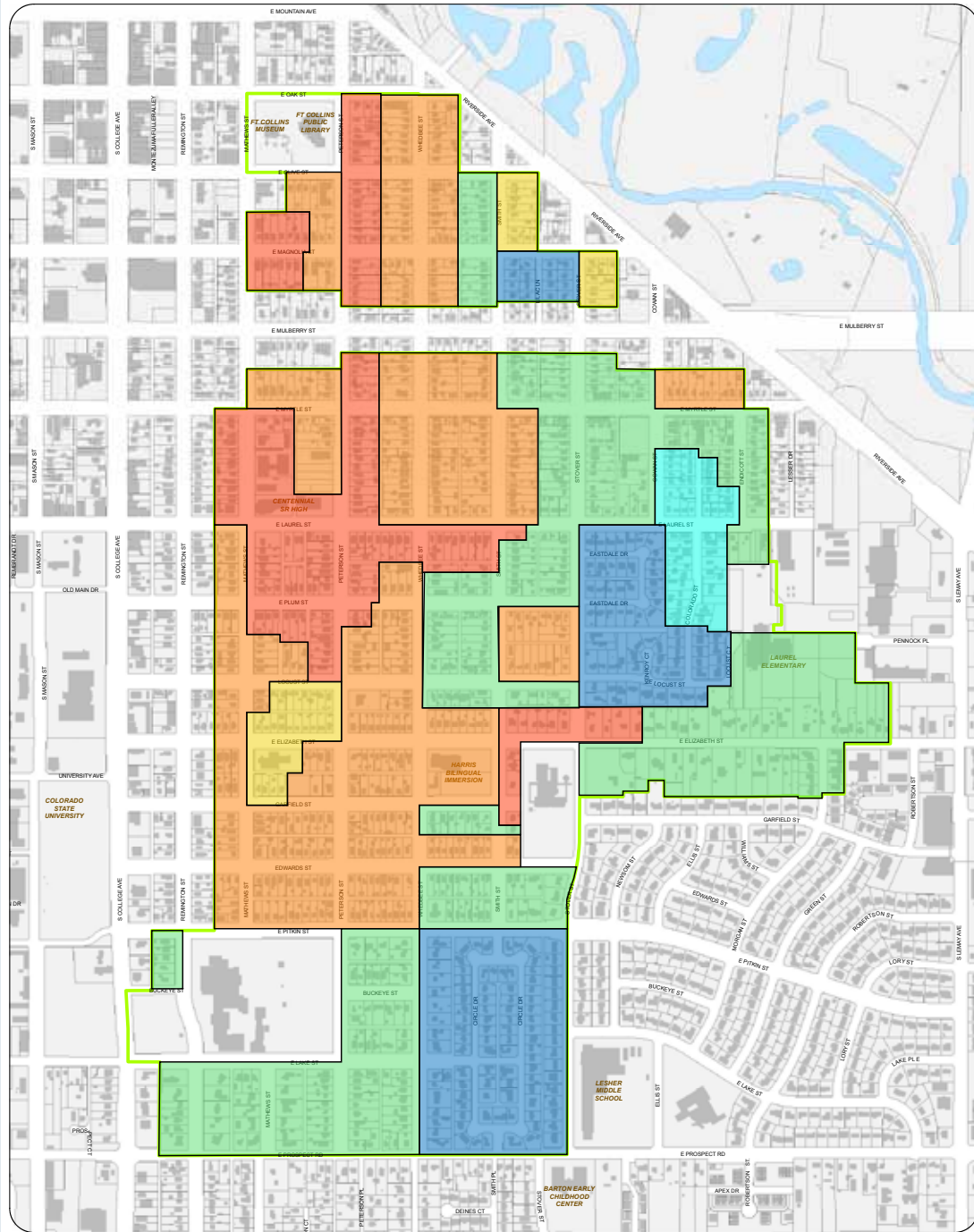

CITY OF FORT COLLINS
GEOGRAPHIC INFORMATION SYSTEM MAP PRODUCTS

These maps are produced as a public service and are not intended to be used for legal purposes. The City of Fort Collins is not responsible for any errors or omissions in this information. The City of Fort Collins is not responsible for any damages or losses resulting from the use of this information. The City of Fort Collins is not responsible for any damages or losses resulting from the use of this information. The City of Fort Collins is not responsible for any damages or losses resulting from the use of this information.

- Character Area 1
- Character Area 2
- Character Area 3
- Character Area 4
- Character Area 5
- Character Area 6



Printed: October 01, 2012

Eastside and Westside Neighborhoods Character Study

Draft Character Areas - Westside Neighborhood

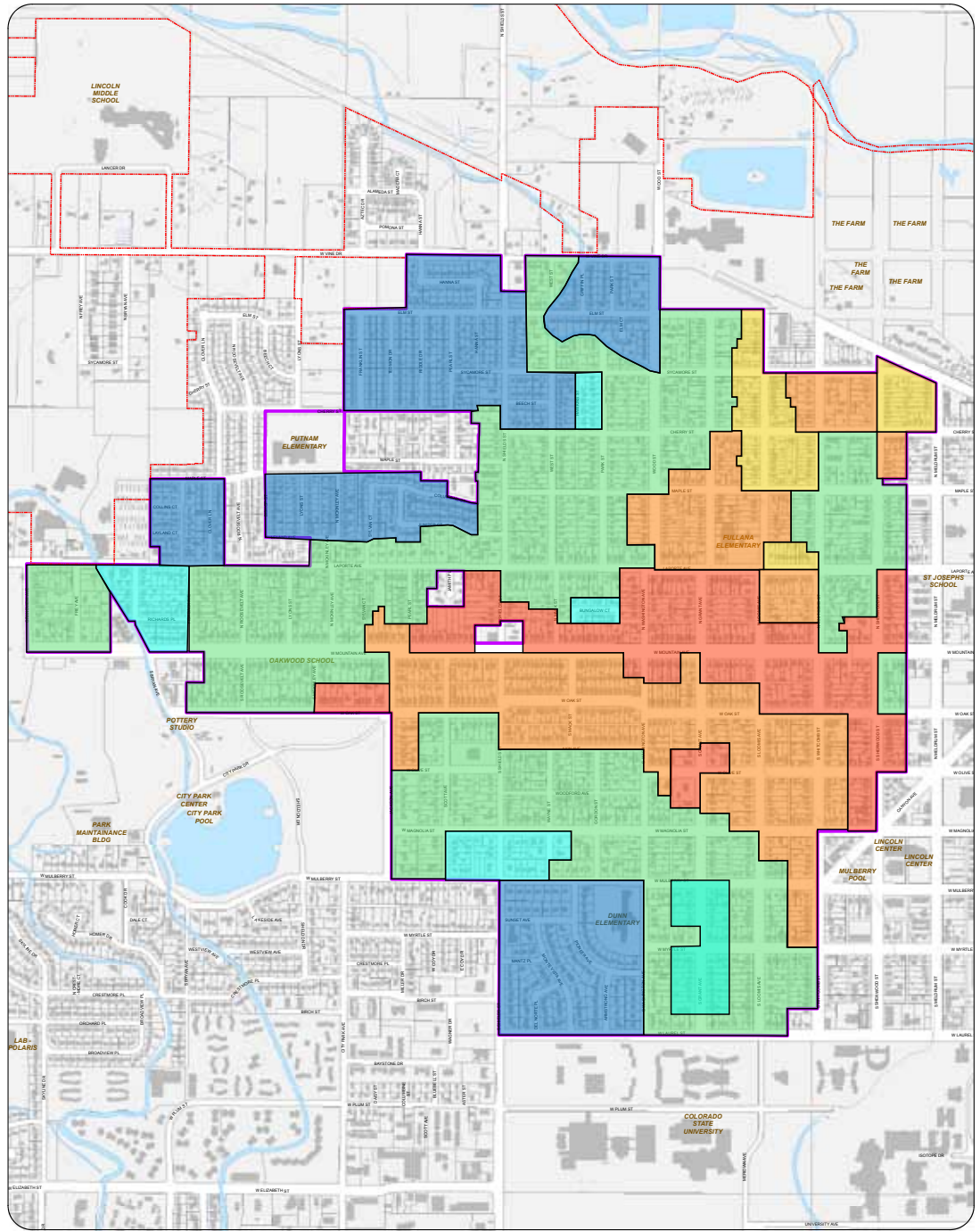









 North



 0 1000 2000 Feet

CITY OF FORT COLLINS
GEOGRAPHIC INFORMATION SYSTEM MAP PRODUCTS

 These products are the result of a geographic information system (GIS) analysis of data provided by the City of Fort Collins and other sources. The City of Fort Collins is not responsible for the accuracy or completeness of the data provided by other sources. The City of Fort Collins is not responsible for the accuracy or completeness of the data provided by other sources. The City of Fort Collins is not responsible for the accuracy or completeness of the data provided by other sources.

-  Character Area 1
-  Character Area 2
-  Character Area 3
-  Character Area 4
-  Character Area 5
-  Character Area 6

Existing Regulations Summary

The zoning code establishes the basic use and dimensional requirements for additions and new construction in the Eastside and Westside Neighborhoods. There are two zone districts within the study area, the Neighborhood Conservation Low Density (N-C-L) and the Neighborhood Conservation Medium Density (N-C-M). Maps illustrating zoning district boundaries in the neighborhoods are provided on pages 50 and 51.

N-C-L District

Buildable Area

The transparent blue “building envelope,” illustrated on the example lot below, is the area of a lot in which it is permissible to build. Additional regulations will then limit the size and type of structures allowed within the envelope.

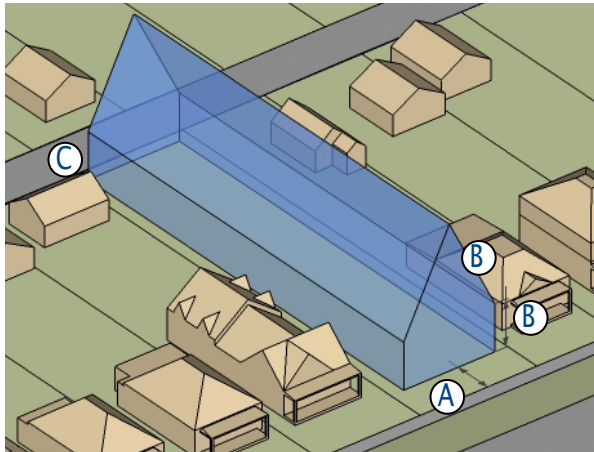

Existing regulations that shape the building envelope in the N-C-L zone district include:

- Ⓐ **Min. front setback:** 15' (20' for a garage)
- Ⓑ **Min. side setback:** 5' plus 1' for every 2' of height over 18'
- Ⓒ **Min. rear setback:** 5' (15' if no alley)

Building Mass and Form

The size and form of a building within the N-C-L building envelope is regulated by the following tools:

Max. FAR: 0.40 (Expressed as a standard requiring a lot area of 2.5 times the aggregate floor area of building situated on the lot)

Max. rear FAR: Square footage in rear half of the lot limited to 12.5% of total lot area

- Ⓓ **Required entry feature:** Porch, landing or portico
- Ⓔ **Max. roof pitch:** 12:12 (shown), min. 2:12
- Ⓕ **Max. height:** 2 stories

Accessory Buildings

There is no limit on the number of accessory buildings allowed in the N-C-L district beyond the total allowable FAR. Accessory dwellings are allowed by administrative review in the N-C-L district, and are also not limited in number.

- Ⓖ **Max. accessory building height:** 1.5 stories or 24' (20' if not habitable), with a max. roof eave height 13'

Sample One-Story N-C-L Building Form

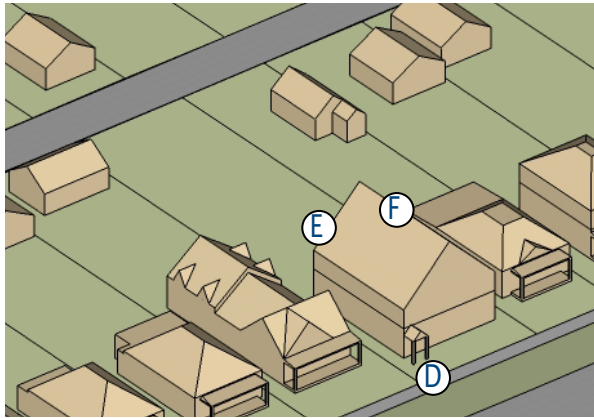

This basic two-story form illustrates one possible configuration for a house that maximizes the building area permitted within the N-C-L building envelope on the sample lot.

Sample Two-Story N-C-L Building Form

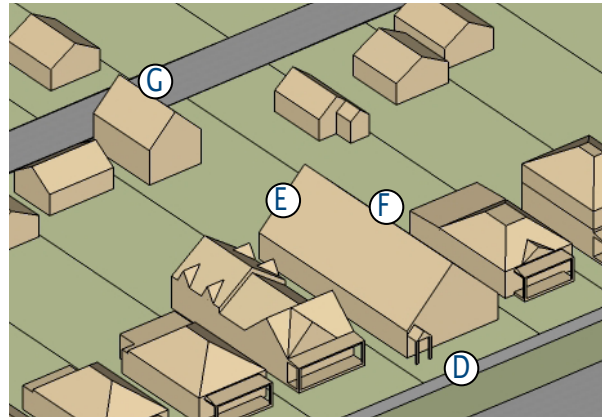

This basic one-story form, with accessory structure, illustrates another possible configuration for a house that maximizes the building area permitted within the N-C-L building envelope on the sample lot.

N-C-M District

Buildable Area

The transparent blue “building envelope,” illustrated on the example lot below, is the area of a lot in which it is permissible to build. Additional regulations will then limit the size and type of structures allowed within the envelope.

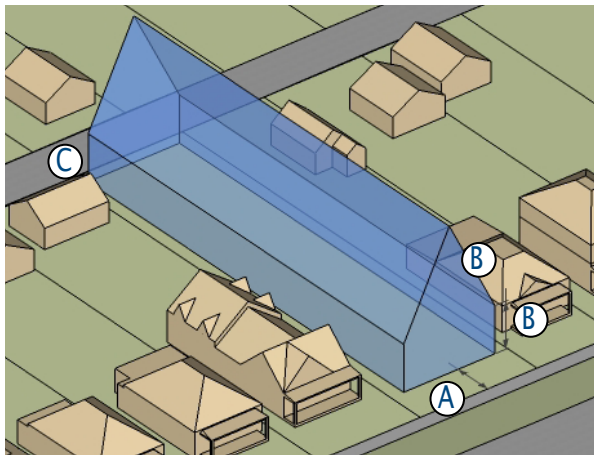

Existing regulations that shape the building envelope in the N-C-M zone district include:

- Ⓐ **Min. front setback:** 15’ (20’ for a garage)
- Ⓑ **Min. side setback:** 5’ plus 1’ for every 2’ of height over 18’
- Ⓒ **Min. rear setback:** 5’ (15’ if no alley)

Building Mass and Form

The size and form of a building within the N-C-M building envelope is regulated by the following tools:

Max. FAR: 0.50 (Expressed as a standard requiring a lot area of 2 times the aggregate floor area of building situated on the lot)

Max. rear FAR: Square footage in rear half of the lot limited to 16.7% of total lot area

Ⓓ **Required entry feature:** Porch, landing or portico

Ⓔ **Max. roof pitch:** 12:12 (shown), min. 2:12

Ⓕ **Max. height:** 2 stories

Accessory Buildings

There is no limit on the number of accessory buildings allowed in the N-C-M district beyond the total allowable FAR. Accessory dwellings are allowed by administrative review in the N-C-M district, and are also not limited in number.

Ⓖ **Max. accessory building height:** 1.5 stories or 24' (20' if not habitable), with a max. roof eave height 13'

Sample Two-Story N-C-M Building Form

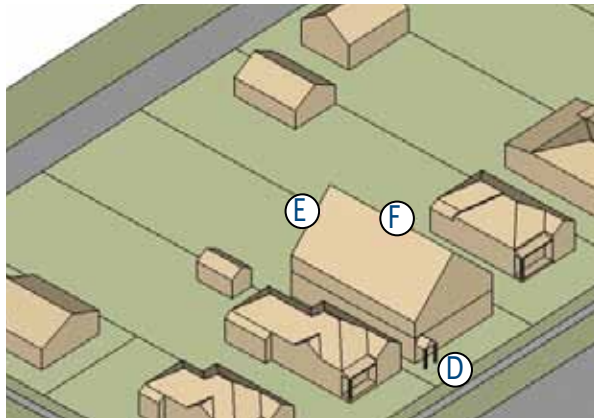

This basic two-story form illustrates one possible configuration for a house that maximizes the building area permitted within the N-C-M building envelope on the sample lot.

Sample One-Story N-C-M Building Form

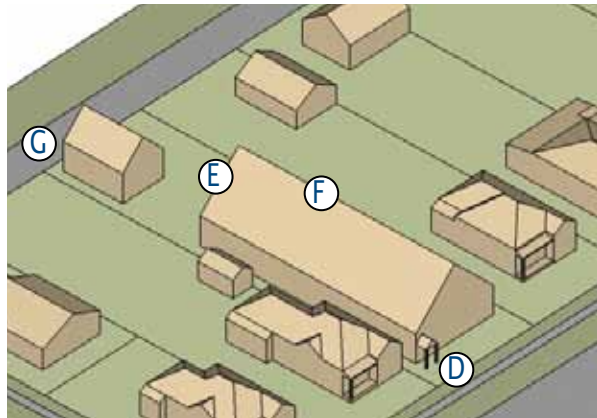

This basic one-story form, with accessory structure, illustrates another possible configuration for a house that maximizes the building area permitted within the N-C-M building envelope on the sample lot.

Eastside and Westside Neighborhoods Character Study

Zoning Districts - Eastside Neighborhood

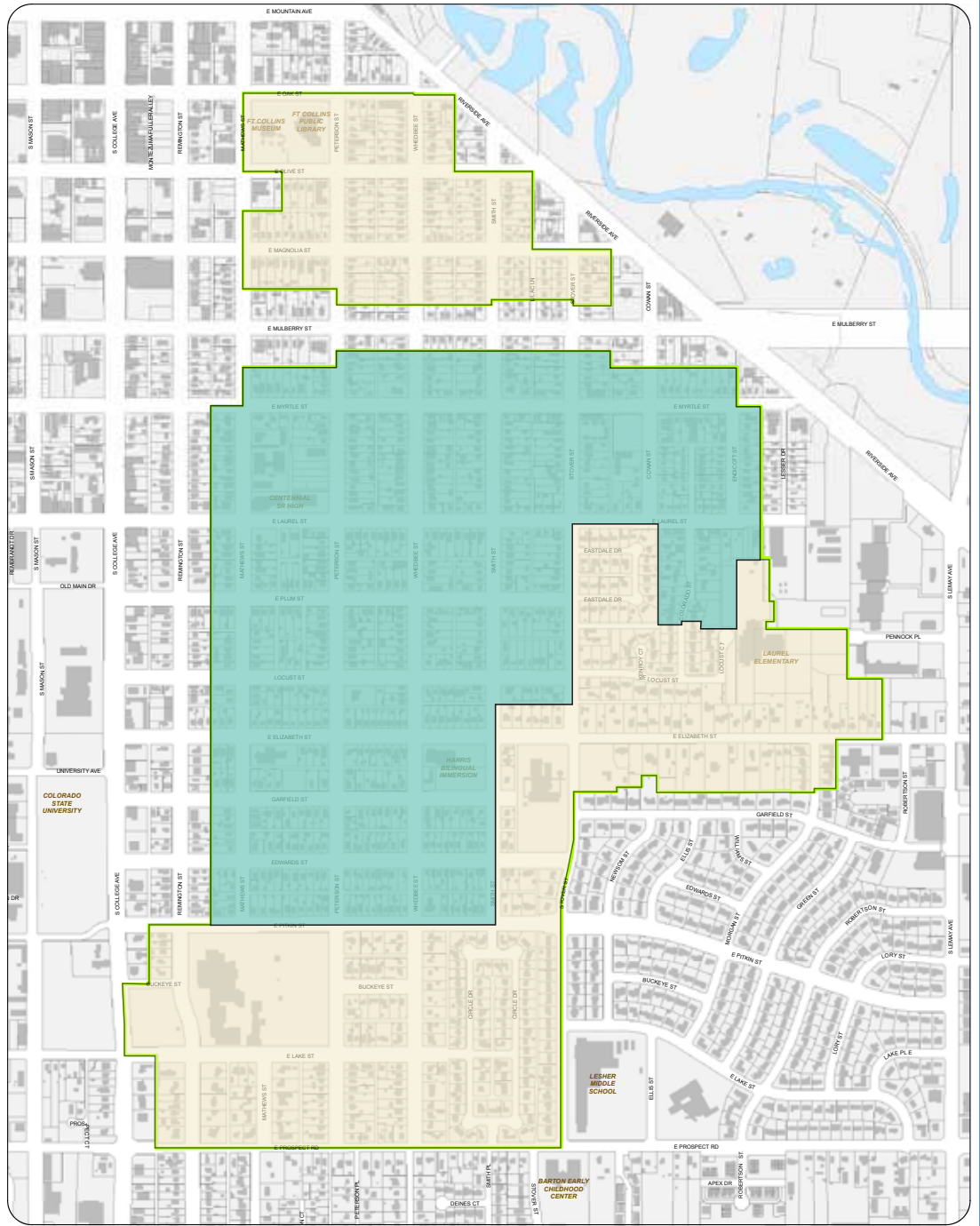

- Neighborhood Conservation Low Density
- Neighborhood Conservation Medium Density



CITY OF FORT COLLINS
GEOGRAPHIC INFORMATION SYSTEM MAP PRODUCTS
 These maps are prepared by the City of Fort Collins GIS Department. The City of Fort Collins is not responsible for any errors or omissions in these maps. The City of Fort Collins is not responsible for any damages or liabilities arising from the use of these maps. The City of Fort Collins is not responsible for any damages or liabilities arising from the use of these maps. The City of Fort Collins is not responsible for any damages or liabilities arising from the use of these maps.



Printed: October 01, 2012

Eastside and Westside Neighborhoods Character Study

Current Zoning - Westside Neighborhood

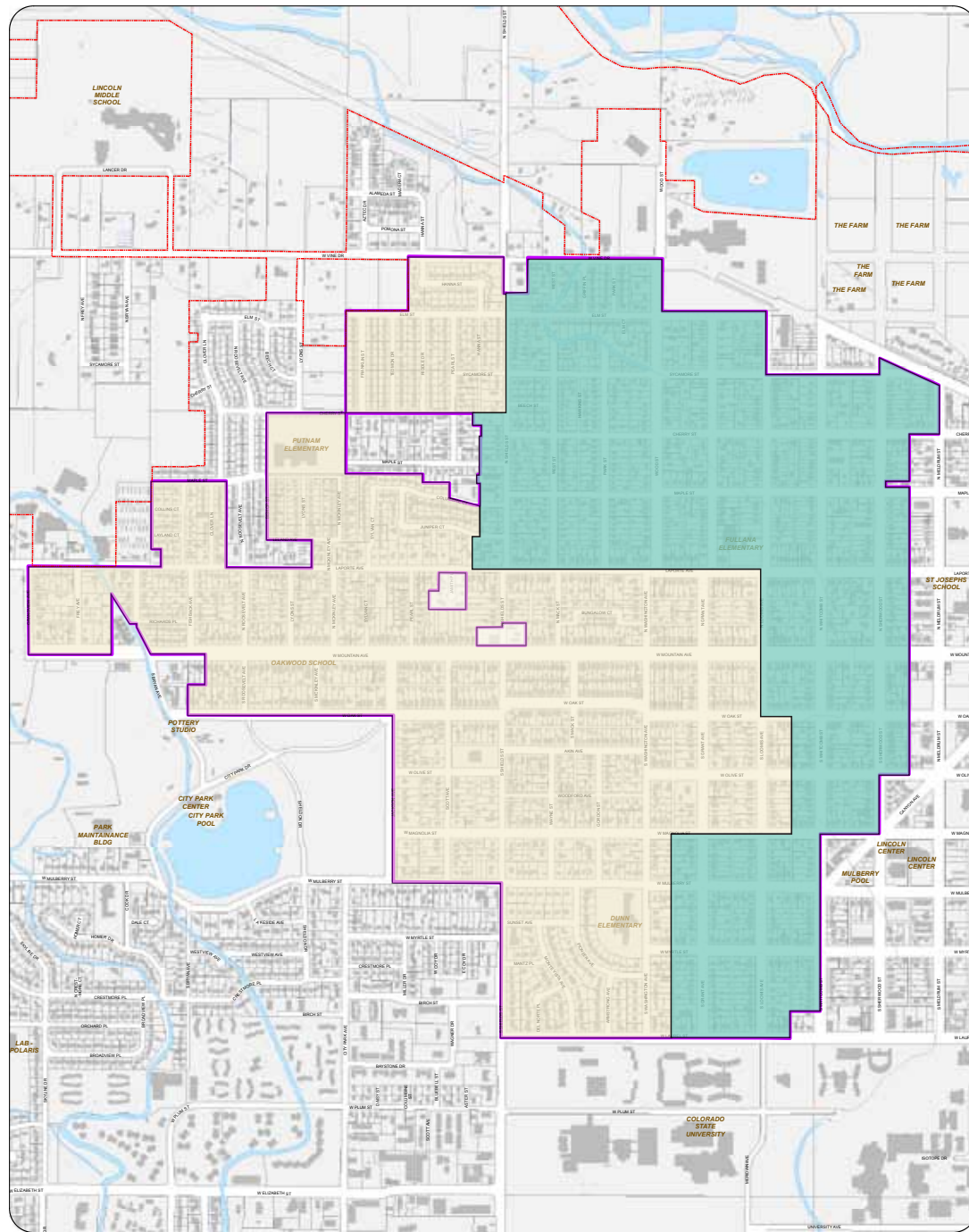

North

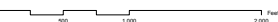

**CITY OF FORT COLLINS
GEOGRAPHIC INFORMATION SYSTEM MAP PRODUCTS**
 This map product is a derivative of the City of Fort Collins GIS data. It is intended for informational purposes only. The City of Fort Collins does not warrant the accuracy, completeness, or timeliness of the data. The City of Fort Collins is not responsible for any errors or omissions in this map product. The City of Fort Collins is not responsible for any damages or liabilities arising from the use of this map product. The City of Fort Collins is not responsible for any damages or liabilities arising from the use of this map product. The City of Fort Collins is not responsible for any damages or liabilities arising from the use of this map product.

- Neighborhood Conservation Low Density (NCL)
- Neighborhood Conservation Medium Density (NCM)



Printed: October 01, 2012

Recent Trends

Across the country many established residential neighborhoods have been experiencing significant changes after years of relative stability. Over the last fifteen years residents began to notice changes in their neighborhoods, such as increased house size and height on additions and new construction. Such changes are indicative of current market trends in which established neighborhoods are becoming more desirable places to live. In some cases, such changes were seen as exciting opportunities. In other cases, residents worried that inappropriate changes could ruin the character of their neighborhood.

The Eastside and Westside Neighborhoods have experienced changes similar to those occurring in many other established residential neighborhoods nationwide. Most activity in the Eastside and Westside Neighborhoods have been additions, which are often of substantial size relative to the existing structure. Both neighborhoods are also experiencing demolition and new construction, with replacement structures generally being significantly larger than the demolished homes.

Trends by Neighborhood

Both the Eastside and Westside Neighborhoods are experiencing significant construction activity. However, the majority of activity (72% of all projects) is occurring in the Westside neighborhood. The Westside also has a higher percentage of new construction by comparison with the Eastside. 7% of recent activity in the Westside is new home construction and 93% is remodels, while only 3% of activity on the Eastside is new home construction and 97% is remodels.

Recent new construction projects in the Westside have generally been larger than those on the Eastside. New homes built recently on the Westside range from 1,465 to 3,653 square feet with an average square footage of 2,376 and an average floor area ratio (FAR) of 0.32. New homes built recently on the Eastside range from 780 to 2,340 square feet with an average square footage of 1,530, and an average FAR of 0.22.



Recent new construction projects in the Westside have generally been larger than those on the Eastside.

Trends by Development Pattern and Lot Type

Within each neighborhood, development trends may vary by different existing development patterns (see "Neighborhood Development Patterns" on page 9 for more information) or on different lot types. Such differing circumstances may also influence how new construction is perceived (i.e., concerns may be greater when a lot is subdivided to allow for the construction of two new homes, or when new construction occurs on an especially large or small lot). Additional evaluation will be necessary to determine the relationship between different development patterns and lot types. Two initial areas of evaluation will include:

- **Lots Large Enough to Subdivide.** The subdivision of lots was mentioned during community feedback as a potential area of concern. Based on the minimum lot frontage and parcel sizes required, approximately 5% of lots on the Eastside and 3% of lots of the Westside could be subdivided.
- **Large Lots in Predominantly Small-Lot Blocks.** Due to the variety of lot and alley forms in the neighborhoods, there are several areas where significantly larger lots occur on a block of predominately smaller lots. About 3% of the lots in both the Eastside and Westside Neighborhoods are significantly larger (at least 3,000 square feet greater) than most others on their block.

Building Permit Trends

GIS data on building permits granted since 1997 show recent increases in construction activity in the Eastside and Westside Neighborhoods. Construction activity in the Eastside and Westside Neighborhoods makes up just under 7% of the total citywide building permits. See "Appendix C: Building Permits" for maps that visually convey this data.

Eastside and Westside Neighborhoods Major Building Permits by 5-year Periods

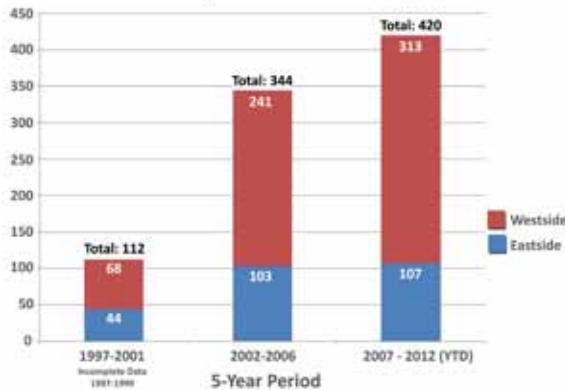

Eastside and Westside Neighborhoods Major Building Permits 1997–October 2012

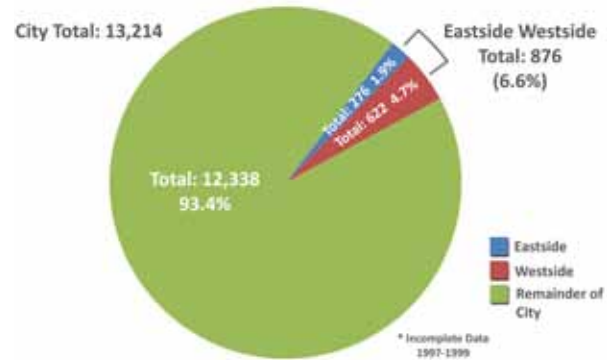

GIS data on building permits granted since 1997 show recent increases in construction activity in the Eastside and Westside Neighborhoods.

Construction activity in the Eastside and Westside Neighborhoods represents just under 7% of total citywide residential building permits since 1997.

Eastside and Westside Neighborhoods Major Building Permits by Year

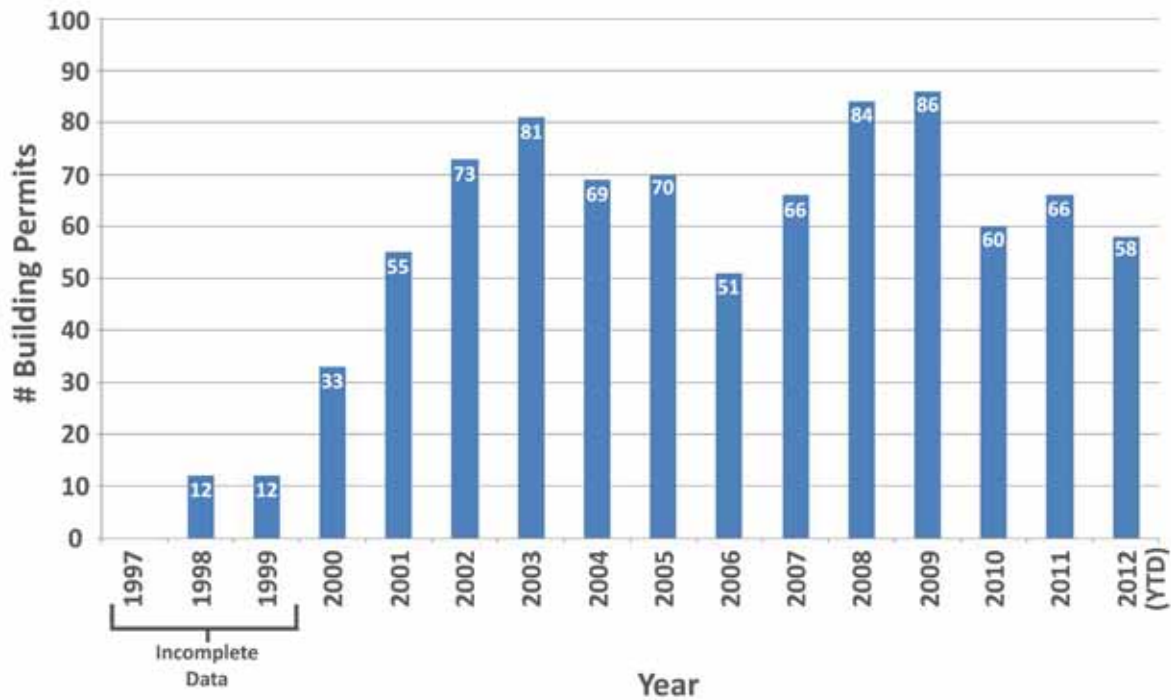

A general increase in building activity in the Eastside and Westside Neighborhoods since 1997 can be seen.

Variance Trends

GIS data on variances since 1997 show steady numbers of variances being granted in the Eastside and Westside Neighborhoods since 2007. See "Appendix D: Variances" for maps that visually convey this data. Variances in the neighborhoods make up nearly 38% of all variances granted citywide. This is significantly greater than the 6.6% of total major building permits the neighborhoods represent.

Eastside and Westside Neighborhoods Variances by 5-year Periods

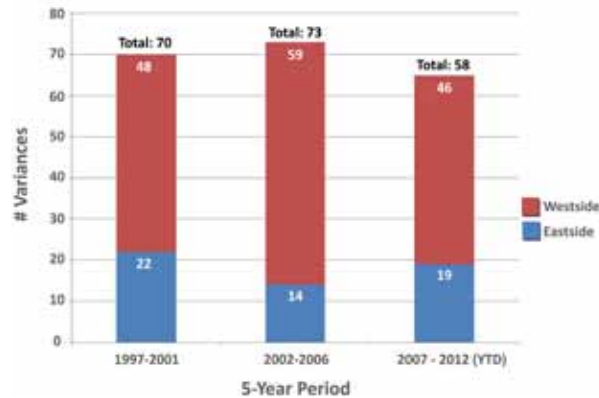

GIS data on variances show steady numbers of variances being granted in the Eastside and Westside Neighborhoods since 1997.

Citywide, Eastside and Westside Neighborhoods Variances 1997-October 2012

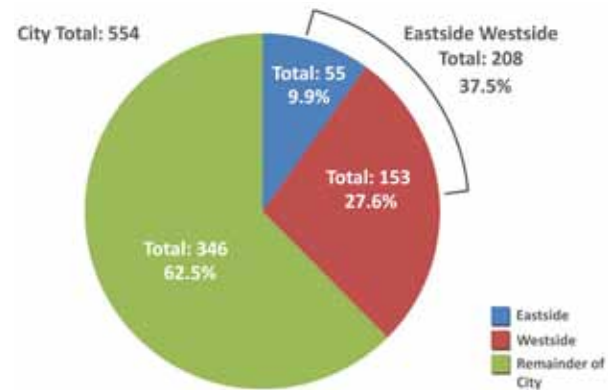

Variances in the Eastside and Westside Neighborhoods make up nearly 38% of all residential variances granted citywide since 1997.

Eastside and Westside Neighborhoods Variances by Year

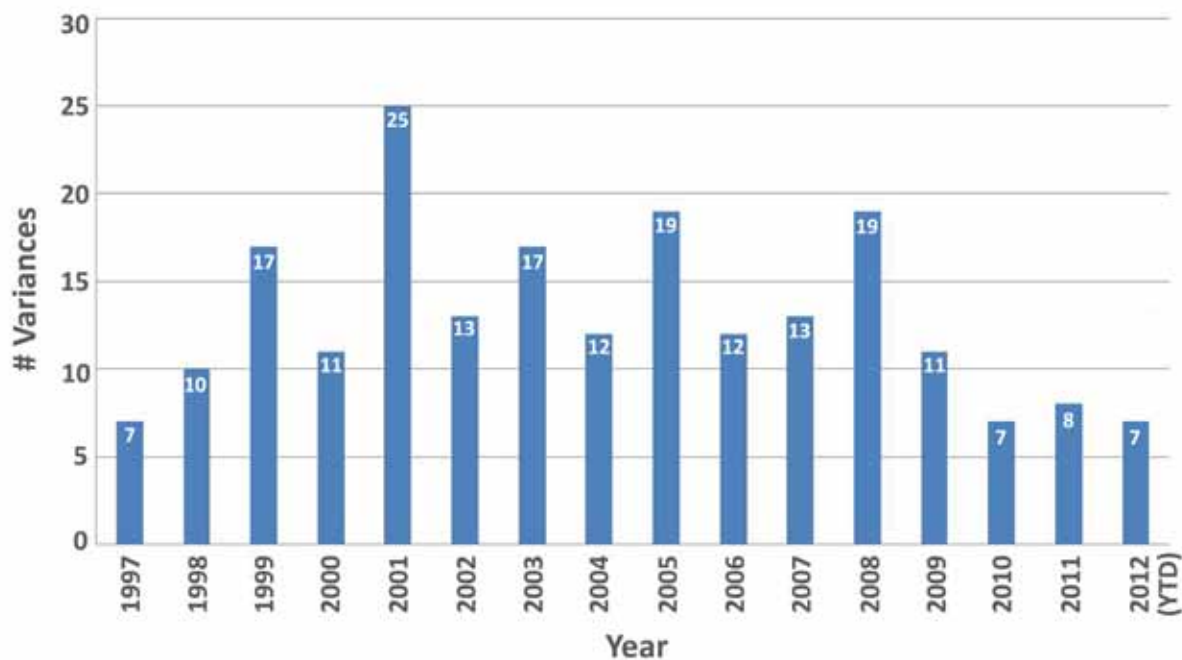

On average, the number of variances granted within the Eastside and Westside Neighborhoods has remained steady since 1997.

Part 2

Community Comments

The Eastside and Westside Neighborhoods are highly valued. However, for many years, residents have expressed concern about the compatibility of some new construction and additions. Previous efforts to address these concerns have ended in controversy. To set the stage for a more inclusive and deliberative consideration of potential solutions, City Council has sought to more clearly define neighborhood objectives and issues through a well-supported and effective public process.

To date, the public process for the Eastside and Westside Neighborhood Character Study has provided a range of outreach venues for community comment, including:

- Neighborhood Workshops
- Working Groups
- Questionnaires and Surveys

This part of the report includes a summary of community comments from each of the outreach venues, followed by observations on the overall themes and preliminary identification of neighborhood objectives and issues that led to the strategy options described in Part 4: "Strategy Options" on page 111.



Part 2 Contents

Neighborhood Workshops	56
July Workshops	56
November Workshop.....	62
Working Groups	69
June Working Groups	69
September Working Groups	71
October Working Groups.....	72
Questionnaires and Surveys.....	73
July Neighborhood Questionnaire.....	73
November Visual Survey.....	78
Community Comment Themes.....	82
Neighborhood Objectives and Issues .	84

City of Fort Collins
Eastside and Westside Neighborhoods Character Study

Neighborhood Workshop

Meeting Objectives: To introduce the project, review neighborhood character, discuss neighborhood objectives and evaluate design alternatives for new construction

Agenda

Project Introduction	6:00
Presentation	6:10
<ul style="list-style-type: none"> • The planning process • Existing context • Development trends • Existing regulations • Potential tools to address neighborhood character • Design alternatives • Introduction to the workshop activities 	
Team Activity #1: Existing Conditions	6:40
<ul style="list-style-type: none"> • What are some key neighborhood assets? • Identify three distinct neighborhood areas • What are some changes occurring in these areas? 	
Team Activity #2: Design Features	7:00
<ul style="list-style-type: none"> • What design elements contribute to neighborhood compatibility? 	
Team Activity #3: Design Alternatives	7:20
<ul style="list-style-type: none"> • Which new construction designs are most compatible? 	
Team Activity #4: Existing Regulations	8:00
<ul style="list-style-type: none"> • Do you have comments on existing regulations? 	
Team Reports	8:15

For more information, visit the project Web site at:
<http://www.fcgov.com/planning/eastwestneighborhoods.php>

Neighborhood Workshops

Neighborhood workshops provide an opportunity for diverse residents and stakeholders to learn about the project, engage in interactive activities to work through issues and options, and provide feedback. They are widely advertised and open to all citizens who wish to participate.

The Eastside and Westside Neighborhood Character Study includes two primary neighborhood workshops. The first occurred in July 2012 and was divided into separate sessions for the Eastside and Westside. The second workshop was held on November 5, 2012 and combined residents and stakeholders from both neighborhoods.

July Workshops

On July 10 and 12, the City hosted neighborhood workshops to introduce the project, explore neighborhood character, explore aspects of design that affect compatibility of new construction, and consider current regulations. A workshop was conducted in each of the neighborhoods, with a total attendance of about 95 participants. An invitation letter was mailed to all owners and residents in the study area. Participants were also invited via email and the City's website.

Each neighborhood workshop began with a visual presentation by the project consultants. The presentation addressed:

- The planning process
- Existing context
- Development trends
- Existing regulations
- Potential tools to address neighborhood character
- Design alternatives
- Aspects of design

Workshop participants then completed four activities in teams of four to eight participants. At the conclusion of the workshops, participants from each team presented their activity results.

Key comments and themes from the July workshops are summarized on the next page, followed by a summary of the results from each of the workshop activities.

Eastside Workshop Themes

About 30 participants attended the Eastside workshop at Laurel Elementary School on July 10. Many participants expressed a desire to find tools to protect specific elements of neighborhood character while also preserving design flexibility for owners and promoting neighborhood affordability. Additional themes in the discussion included:

- Participants often cited the mature tree canopy as a key neighborhood asset
- Participants generally agreed on the key features of new development that influence neighborhood character and compatibility.
- Participants generally agreed that compatible building massing would help new construction fit into the neighborhood.
- Some participants stated that even though the activities identified aspects of design that help buildings fit in, they felt that the potential for incompatible development was exaggerated.



Westside Workshop Themes

About 65 participants attended the Westside workshop at Putnam Elementary School on July 12. Many participants expressed an interest in preserving the design diversity of the neighborhood while ensuring that new construction does not have negative impacts on neighborhood character. Additional themes in the discussion included:

- Participants often cited City Park, historic homes, alleys and Beaver's Market as key neighborhood assets.
- Some participants expressed interest in tools to support neighborhood consultation and dialogue.
- Some participants indicated that any tools to address neighborhood character should be highly context sensitive (including consideration of adjacent properties).

Additional participant feedback is provided in "Workshop Activities" beginning on page 58.

Observations

Many workshop participants expressed general agreement on neighborhood assets, objectives and potential concerns. However, they often expressed a diversity of opinion on possible future strategies or actions.



Participants marked neighborhood contexts, unique subareas and specific concerns on an aerial map of the Eastside or Westside neighborhood.

Workshop Activities

Participants at each neighborhood workshop completed four team activities designed to stimulate discussion and generate feedback on neighborhood assets, existing context, compatible design features, and existing regulations. Teams spent about 30 minutes completing each activity. An individual worksheet was also available for participants to provide comments apart from the team activities.

Activity #1: Existing Conditions

This was a two-part activity. Participants first identified and listed existing neighborhood assets. They then identified different subareas or "contexts" within their neighborhood.

In the first part of the activity, commonly cited assets included:

- Diversity of house size, design and resident income
- Lack of architectural or other HOA-type restrictions
- Proximity to Downtown
- Walkability and bicycle access
- Wide streets
- Mature tree canopy and landscaping

In the second part of the activity, participants marked neighborhood contexts, unique subareas and specific concerns on a poster map of the Eastside or Westside. Common map themes included:

- Identification of subareas anchored by community resources such as schools and parks
- Identification of neighborhood contexts differentiated by street layout, building age, ownership patterns or level of renovation and new construction

Map feedback provided by workshop participants informed development of the character areas described on page 9.

Activity #2: Design Features

In this activity, participants cut, pasted and captioned photographs of neighborhood houses and streetscapes to identify design features of homes that fit with their neighborhoods.

Participants identified features that are characteristic of a compatible "Old Town" home, including:

- Front porches and general street presence
- Front yard trees
- Small scale
- Larger structures with varied massing

Participants identified features that are generally out of character with the Eastside and Westside, including:

- Facades dominated by garage doors or parking areas
- Houses that appear to be significantly more massive than the structures around them

In many cases, participants also indicated that context influences the appropriateness of design features. They identified features that could be appropriate in some, but not all, areas of the neighborhoods, including:

- Visible garage doors or parking areas
- Very large homes
- Ultramodern designs using contemporary materials
- Especially large or small front yard areas



Participants used photographs of traditional neighborhoods and new construction to identify design features that help make properties compatible with their neighborhoods.



Photographs illustrating generous front porches and existing small scale character were among those most often selected as illustrating appropriate design features.





Participants reviewed a variety of hypothetical new construction designs on a sample lot in one of five neighborhood contexts.



Participants identified a number of design features that could help reduce the perceived mass and scale of new construction and help it fit in with its surrounding context, including front porches, dormers, varied rooflines, one-story elements and side wall offsets.

Activity #3: Design Alternatives

In this activity, participants reviewed a variety of hypothetical new construction designs on a sample lot in one of five neighborhood contexts. Participants indicated whether they felt that each design was compatible with its surrounding context and identified any illustrated design features that helped promote compatibility.

Each context was illustrated with a three-dimensional computer model of existing conditions in a three- to four-block area of the Eastside or Westside neighborhoods. New construction designs on the sample lot in each context illustrated a number of variables, including height, lot coverage (the percent of the lot covered by buildings), building square footage and wall length/articulation. Understanding which design variables contribute most to neighborhood compatibility will help determine how new construction can best fit into a variety of neighborhood contexts.

Participants identified a number of design features that could help reduce the perceived mass and scale of new construction and help it fit in with its surrounding context. Identified features included:

- One-story elements along the side of a two-story house where the context is one story
- One-story elements on the front of a two-story house
- Side wall offsets
- Traditional roof pitch
- Roof ridge offsets
- Consistent spacing and rhythm of buildings along the block

Participants also identified concerns, including:

- The proportion of a building to the size of its lot
- Large, boxy building masses that are out of character with their surrounding context
- Wall height, in relation to closeness of side yard set back
- Loss of solar access for properties to the north

Activity #4: Existing Regulations

In this activity, participants reviewed and provided comments on the zoning regulations that currently apply to new construction in the Eastside and Westside.

Existing zoning regulations in the Neighborhood Conservation Low Density (N-C-L) and Neighborhood Conservation Medium Density (N-C-M) zone districts were illustrated on a graphic poster.

Participants identified a number of concerns, including:

- Concern that additional regulations could limit design flexibility and produce higher costs
- Concern that existing regulations do not adequately address context or promote neighborhood dialogue
- Concern that structures built on raised grade may tower over neighbors based on the existing height measurement system
- Concern with ease of obtaining height and setback variances

Individual Worksheet

In addition to the four formal team activities, an individual worksheet was provided for workshop participants to submit optional comments and feedback.

About a third of participants at each workshop completed an individual worksheet. All indicated that they were property owners in the neighborhoods.

Key themes in the worksheet responses include:

- Many participants indicated that there are both benefits and concerns associated with changes in the neighborhoods, including benefits associated with larger houses for new families and concerns with loss of green space and solar access.
- Most participants (74%) felt that there is an issue with some new construction in the neighborhoods, although many felt that issues were limited to certain areas of the neighborhoods, or to a small number of projects.
- Few participants (11%) specifically indicated that they thought there was no issue with new construction in the neighborhoods.

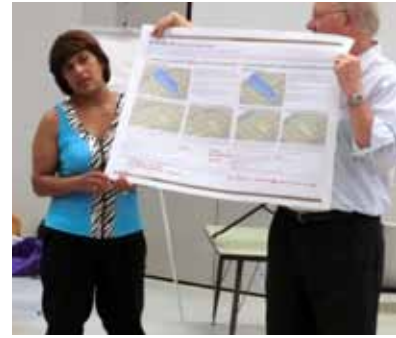

Participants reviewed and provided comments on the zoning regulations that currently shape new construction in the Eastside and Westside Neighborhoods.

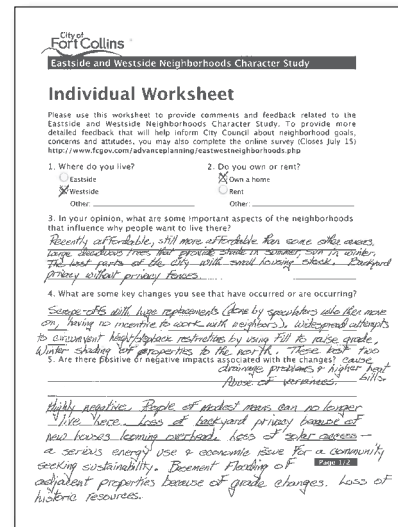

Observations

Based on workshop participant responses, addressing potential new construction issues in focused ways (i.e., only addressing the largest structures or particular types of lots) could satisfy many concerns.



City staff hosted the November neighborhood workshop at the Lincoln Center.

Live Polling

A live polling system was used to collect immediate feedback from workshop participants on alternative strategies to address identified neighborhood objectives and issues. Participants answered questions individually using handheld polling devices, then all results were shown on screen for group discussion.

November Workshop

On November 5, the City hosted a neighborhood workshop to review the character and context of the neighborhoods, summarize identified neighborhood objectives and issues and introduce options for City Council consideration. The workshop brought about 60 Eastside and Westside residents together with other stakeholders to facilitate an informed dialogue with multiple viewpoints. Postcard invitations were mailed to all owners and residents in the study area. Participants were also invited via email and the City's website.

The workshop began with a visual presentation by project consultants. The presentation addressed:

- Study goal and process
- The character and context of the neighborhoods
- What was heard from the community in Phase 1
- Identified objectives and issues
- Introduction to the character areas (Activity #1)
- Potential tools and design variables (Activity #2)
- Draft strategy options (Activity #3)
- Next steps

Workshop participants then completed three activities. Key comments and themes are summarized below, followed by a summary of the results from each of the workshop activities.

Workshop Themes

Many participants expressed support for the concept of character areas and most of the suggested strategy options, especially those using education and process tools such as design handbooks/guidelines and expanded notification of variances. Tools to address the measurement method for building height at the side yard and floor area ratio (FAR) also received relatively strong support. Opinions were more mixed about regulatory design tools, but most workshop participants continued to support tools to address building massing. Relatively strong support for addressing solar access expressed by workshop and online survey participants helped inform adjustments to the suggested strategy option described in Part 4.

Workshop Activities

Participants at the second neighborhood workshop completed three team activities to provide feedback on alternative strategies to address identified neighborhood objectives and issues. Each activity began with several "live polling" questions that participants answered individually using handheld polling devices and finished with a 15 minute group discussion.



Participants at the second neighborhood workshop completed three team activities to provide feedback on alternative strategies to address identified neighborhood objectives and issues.

An initial live polling question asked participants to select the three most pressing neighborhood issues that have been identified through the public process to date. As summarized below, overly large homes, looming impacts on neighbors and reduction of solar access were seen as the most important issues.

Which of the following do you perceive as the greatest issues?

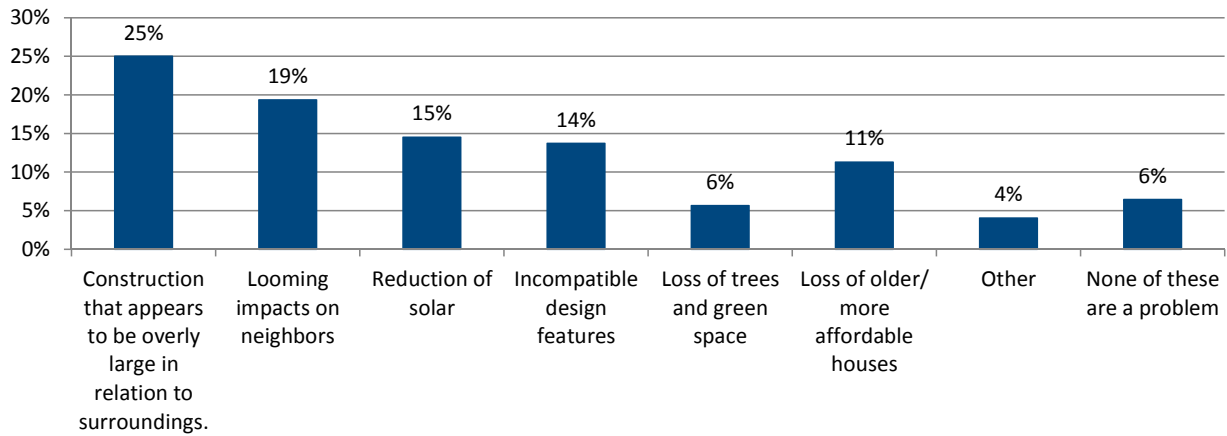



Activity #1: Draft Character Areas

In this activity, participants were given a poster mapping and describing the six identified draft character areas in the Eastside and Westside neighborhoods as summarized on page 28. They were then asked what additional features should be considered in the character area descriptions. Common features identified include:

- Owner occupancy vs. rental rates
- Building size/massing/FAR
- Setbacks/relationships between buildings
- Preservation/designation
- Good character area descriptions
- Streetscape/landscape

As summarized in the chart below, a live polling question also generated feedback on how the character areas should be used.

How should the character areas be used?

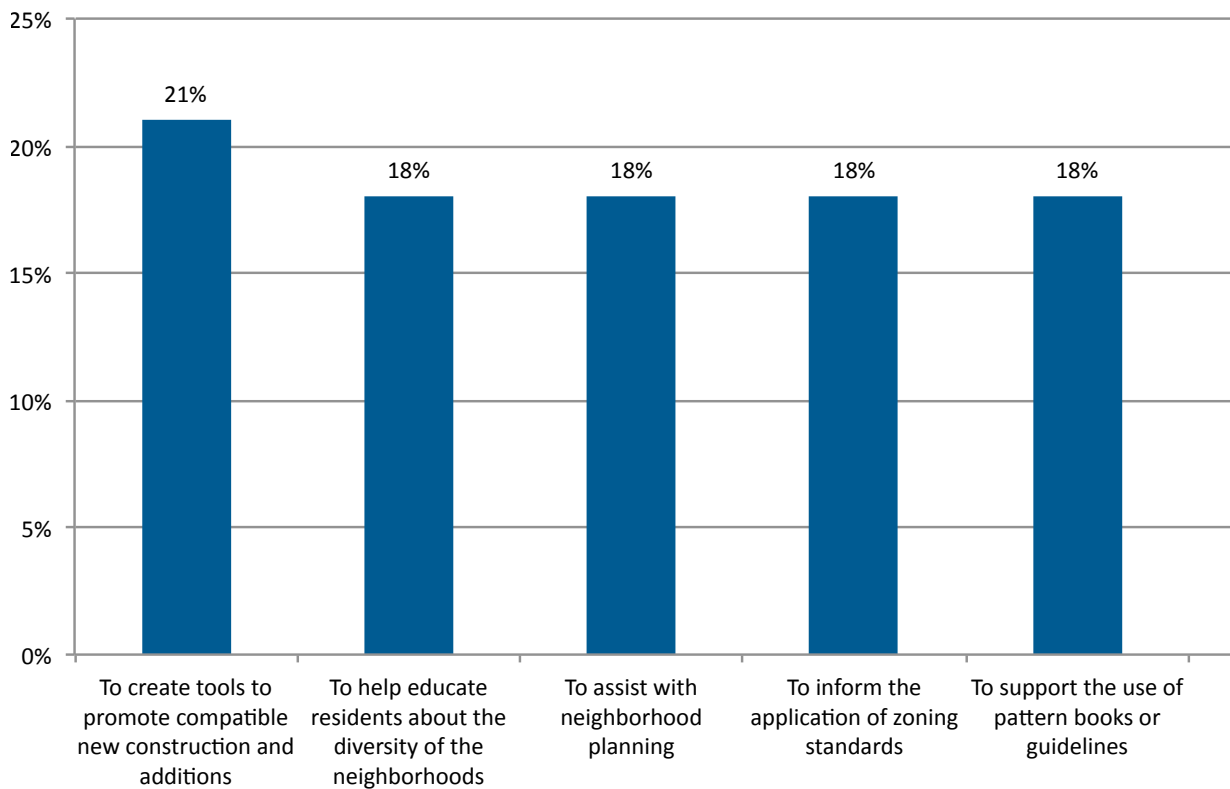

Activity #2: Design Variables

In this activity, participants reviewed four models on the same lot representing varied combinations of the alternative tools to address building mass and scale, and provided feedback on their effectiveness. Participants were not told specifics on what each model showed, and were asked to respond only to the images presented. Information on the models is provided here to facilitate analysis of participant feedback.

Common elements identified which contribute to neighborhood compatibility include:

- Front porch
- Dormers
- Sidewall notch
- Stepped down side wall height
- Height step down on the north side to provide better solar access
- Variety of roof lines
- Hip roof
- Low to moderate roof angle
- Keeping a lower scale at street
- Variation of wall planes
- Interesting front façade
- Front overhang/porch at same height as existing buildings
- Narrow front facade width

Common themes for how neighborhood compatibility could be improved include:

- Reduce overall building size
- Reduce building height
- Reduce looming
- Do not block solar access
- Decrease back to front length
- Change gable face to hip roof to increase compatibility
- Reduce building impacts neighbor's privacy.
- Less 'blocky'

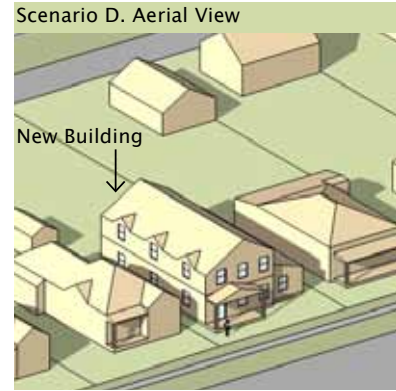

Participants identified models with lower side wall heights that maintain solar access to neighbors as having a high level of compatibility with the neighborhood context.

As summarized in the charts below, live polling question also asked which neighborhood tools should be used, and which design variables should be addressed to promote compatibility.

Which neighborhood tools should be used, if any?

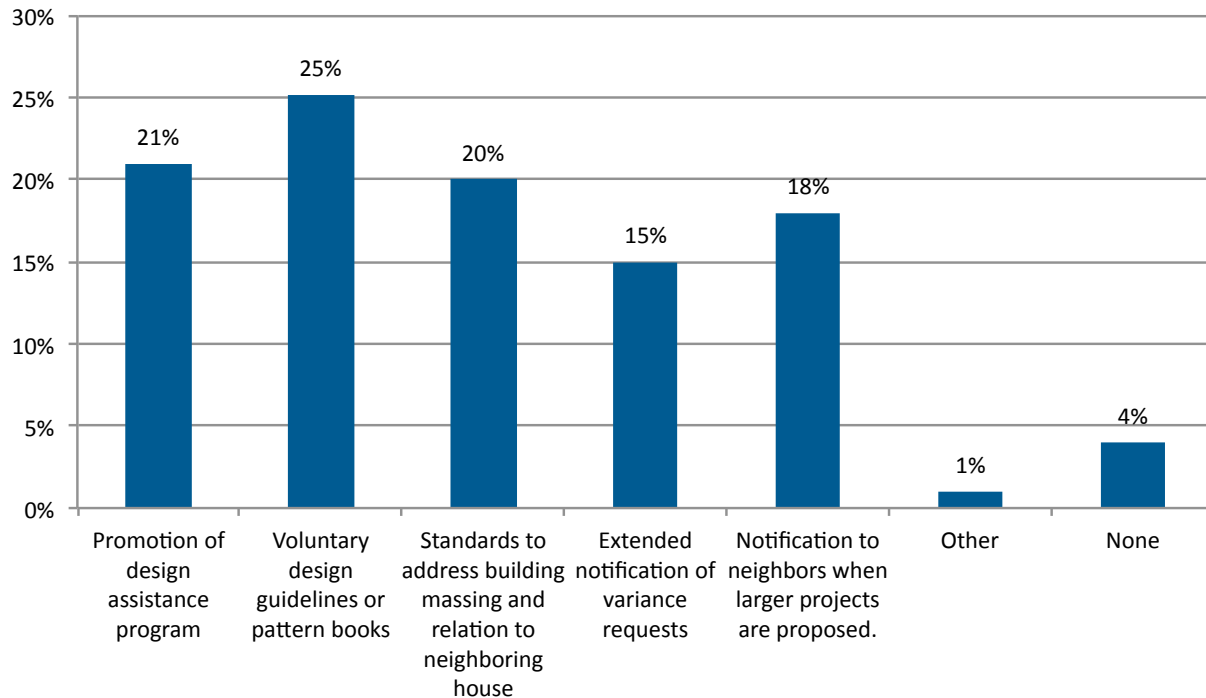

Which design variables should be addressed to promote compatibility, if any?

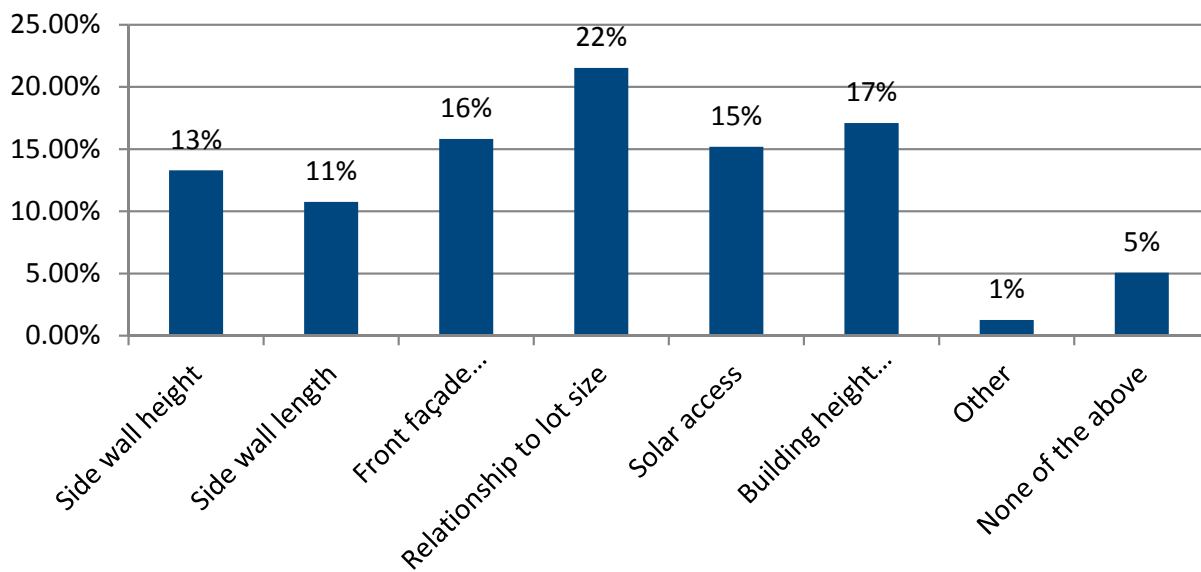

Activity #3: Draft Strategy Options

In this activity, participants were given a poster outlining the draft strategy options to date for consideration. Common strategy options participants expressed support for include:

- Promote design assistance
- Expand notification of variances
- Address solar access

As summarized in the chart below, a series of live polling questions also asked about how beneficial each strategy option would be (Note that not all percentages add to 100% because some participants selected "don't know.")

How beneficial do you think the following strategy options would be for addressing the identified neighborhood objectives and issues? (Part 1)

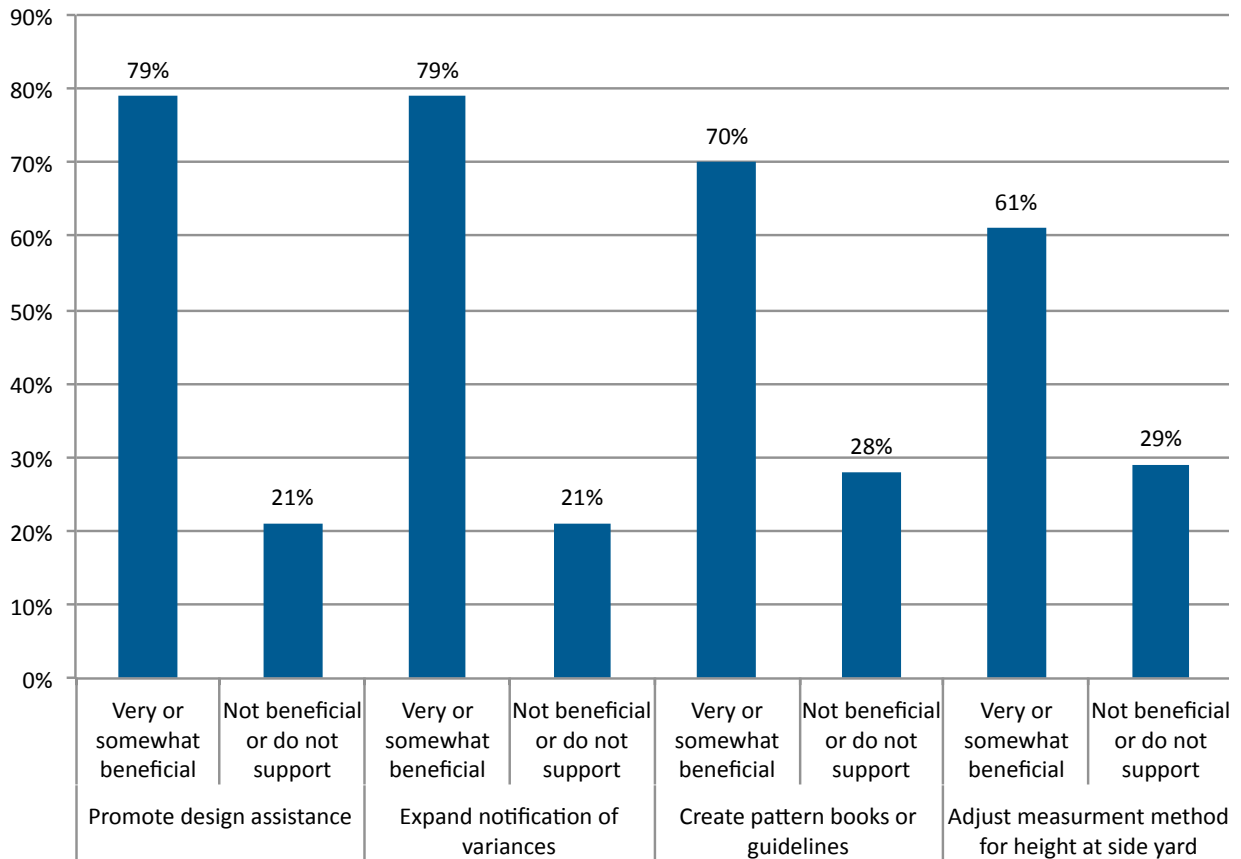

How beneficial do you think the following strategy options would be for addressing the identified neighborhood objectives and issues? (Part 2)

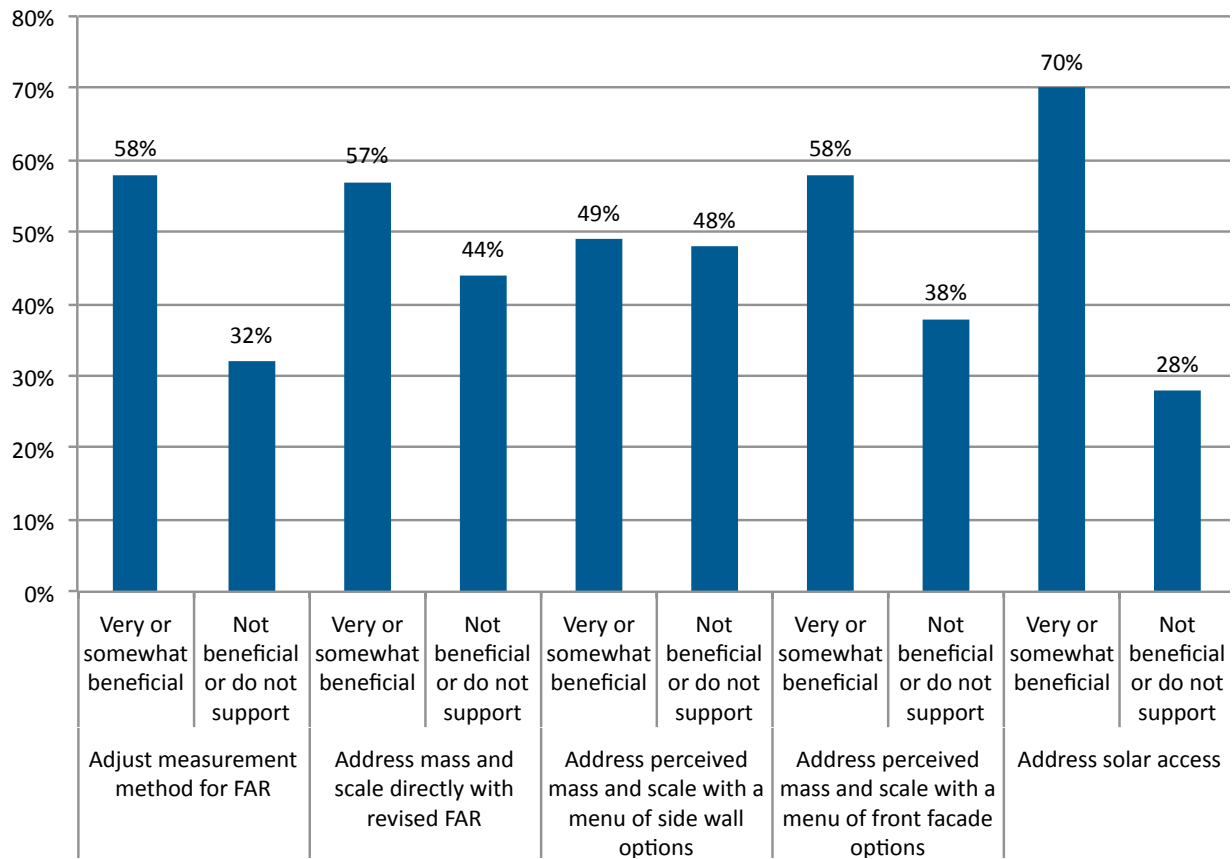

Individual Comments/Questions

In addition to the formal team activities and polling questions, an individual comments form was provided for workshop participants to submit optional comments and feedback. Key themes in the individual worksheet responses include:

- "Solar access has to be protected. This is where additions/remodel/new construction actually harm neighbors, not just offend their aesthetics."
- Address issues with FAR and Solar access protection, "these are the strategies that directly address the problems"
- "I think this committee has listened, taken feedback seriously, and shaped the discussion in a meaningful, thoughtful, and non-confrontational manner."
- "The existing regulations are sufficient and no additional action is necessary." Focus on enforcement and the ease of obtaining a variance rather than additional regulations."

Working Groups

Working group sessions provide opportunities for community members with diverse interests to discuss objectives, refine issues and outline potential strategies in a small group setting. The sessions were advertised on the City's web site and invitations were sent to the City's email list of interested residents and stakeholders.

The Eastside and Westside Neighborhood Character Study includes several sets of working group meetings. The first were held in June 2012 and included sessions for Eastside residents, Westside residents and real estate industry professionals. Subsequent sessions brought these diverse stakeholders together to discuss strategy options and provide feedback on the public participation process.

June Working Groups

On June 14, 2012, the City hosted three preliminary working group meetings for Eastside residents, Westside residents and real estate industry professionals. There was no deliberation, and the outcome was simply for the study team to gain additional perspective as the project was being launched publicly.

At each session, City staff provided a general introduction and project consultants facilitated meeting discussion. Many working group participants indicated that the meeting format supported useful dialogue, and expressed desire to participate in future meetings with a similar format. However, some participants requested that future sessions include a wider range of viewpoints to begin a process of deliberation and conflict resolution.

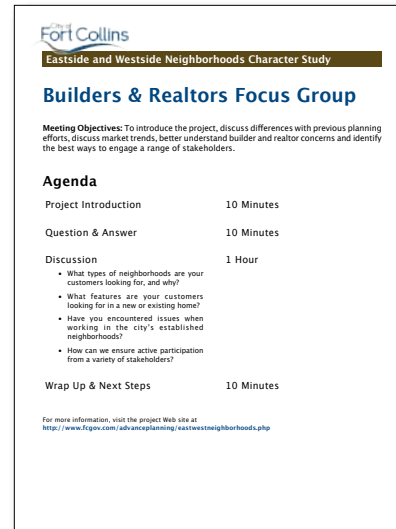

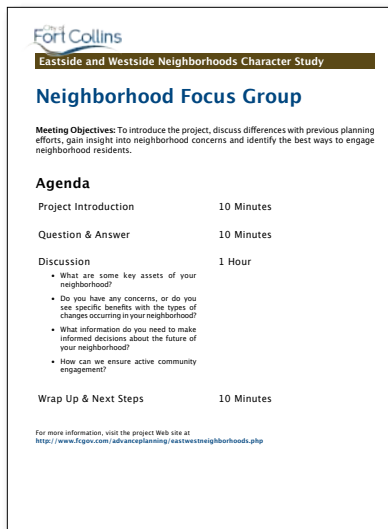

Market Trends and Preferences

Real estate industry professionals provided insight into current market trends and home buyer preferences. Observations included:

- Old Town neighborhoods are highly desirable.
- The market for Old Town properties has significantly outperformed the market in more suburban areas.
- Buyers seek pedestrian-friendly neighborhoods with a sense of community and architectural diversity.
- Buyers most often seek 1,500 to 2,200 square foot homes with two to three bedrooms.
- Most buyers do not want to be subject to restrictive homeowner's association rules.

June Neighborhood Working Groups

Two meetings of residents were held for Eastside and Westside areas respectively. Fifteen Eastside residents and fourteen Westside residents attended. Participants answered four key questions:

- What are some key assets of your neighborhood?
- Do you have any concerns, or do you see specific benefits, with the types of changes occurring in your neighborhood?
- What information do you need to make informed decisions about the future of your neighborhood?
- How can we ensure active community engagement?

Key discussion themes revolved around the neighborhoods as great places to live with a strong sense of community. While many participants were concerned with some large new construction negatively impacting neighborhood character and quality of life, questions also arose regarding the appropriateness of limiting owners' choices, given the degree of subjectivity in what is compatible. Some participants also expressed frustration that the 2011 ordinance had been rescinded and noted that they felt organized economic interests were inherently more powerful than residents.

June Real Estate Working Group

This meeting included a total of nine builders, realtors, and architects. Participants answered four key questions:

- What types of neighborhoods are your customers looking for, and why?
- What features are your customers looking for in a new or existing home?
- Have you encountered issues when working in the city's established neighborhoods?
- How can we ensure active participation from a variety of stakeholders?

A key discussion theme was that the neighborhoods are highly successful in the market, with some of the highest values and shortest times on the market. This is related to concern that any new regulations would negatively affect the market and unduly limit owners' flexibility. Several real estate professionals also noted the entire community should be engaged in the dialogue rather than just Eastside and Westside residents.

More detailed information on discussion results is provided in the separate *Phase 1 Report*.

September Working Groups

On September 12 and 13, 2012, the City hosted two working group meetings to discuss issues identified in the study's first phase and explore potential tools and strategies to address those issues. The meetings included a mixed group of Eastside and Westside residents as well as industry professionals in real estate, construction and architecture who have worked in the neighborhoods.

At each session, City staff and project consultants gave a presentation on the results of the study's first phase and introduced potential tools for discussion in Phase 2. Participants then worked together to discuss these tools, recording key points of their discussion on a poster in the following categories:

- Education and Communication Tools
- Process and Administration Tools
- Design Standards

Although working group participants expressed a diversity of opinions, a number of general themes emerged from the discussion, including:

- Strong support for educational tools such as non-mandatory design guidelines
- Strong support for evaluating changes to the way that building height is measured to better account for the impact of grade changes on adjacent properties
- Strong support for tools that encourage diversity in building design
- Support for process tools such as neighborhood notification requirements
- Support for basing the application of tools on specific thresholds such as project size or new construction vs. additions
- Interest in examining tools that would address the compatibility of large additions or new construction
- Interest in maintaining a "no change" option as that would keep existing processes and regulations in place without revisions

More detailed information on discussion results is provided in the separate *Summary of October Working Groups* document.

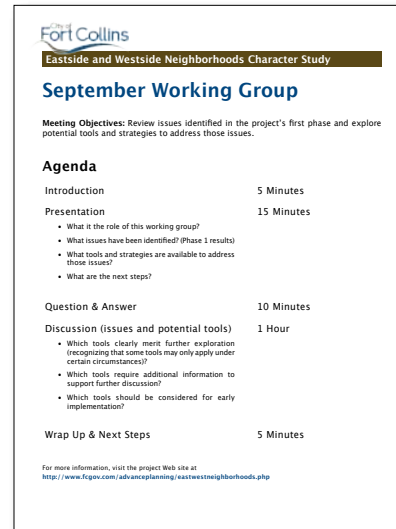

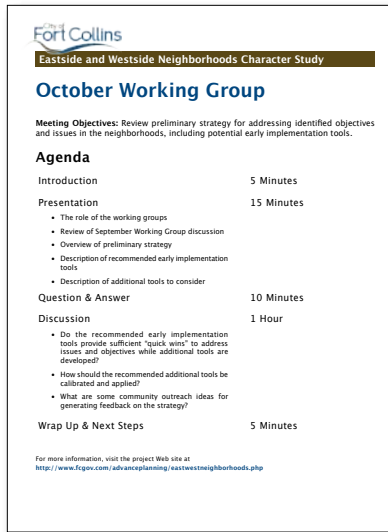

October Working Groups

On October 3 and 8, 2012, the City hosted three working group meetings to review preliminary strategy options for addressing identified objectives and issues in the neighborhoods. The meetings included a mixed group of Eastside and Westside residents as well as industry professionals in real estate, construction and architecture who have worked in the neighborhoods. There were about 45 total working group participants.

At each session, City staff and project consultants gave a presentation on tools suggested for further consideration based on overall community comments and September working group discussion. Participants then worked together to discuss and comment on strategy options for using the tools.

Key themes in the October working group discussion included:

- **Process and education tools received the broadest support.** Most participants supported tools to raise awareness and promote compatible design through education and process tools such as:
 - » Increasing awareness of design assistance available from the City
 - » Developing design guidelines or a pattern book
 - » Extending neighborhood notification of new construction
- **Many participants felt that new or adjusted design standards may be necessary.** Many (but not all) participants felt that one or more design standards would also be necessary to fully address identified issues. They are:
 - » Adjust measurement of building height at the side yard setback.
 - » Consider adjusting FAR standards and/or FAR measurement (if solar access is not specifically addressed).
 - » Consider building wall articulation/building massing standards (if FAR is not addressed).
 - » Consider addressing solar access (if FAR standards are not addressed).
- **Some participants continue to feel that no action is necessary.** It is also important to note that several participants felt that a "no change" option would be most appropriate.

Questionnaires and Surveys

Questionnaires and surveys provide a venue for feedback on study concepts by the widest variety of participants, including residents and stakeholders who are unable to attend workshops or working groups. They are advertised online and via mailings, and are conducted primarily online, with the option to complete a printed version.

The Eastside and Westside Neighborhood Character Study included a preliminary online questionnaire in July 2012 and a more detailed follow up visual survey in November 2012.

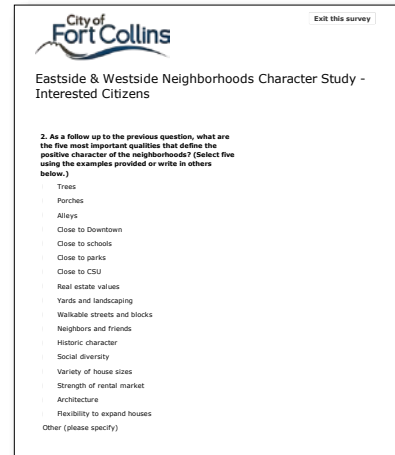

July Neighborhood Questionnaire

An online questionnaire was posted from July 2 to 15, 2012, to collect information on valued neighborhood qualities, clarify objectives and identify potential issues and concerns. Separate (but identical) questionnaires were targeted to property owners, tenants and the general public (interested citizens), allowing separate response tabulations for each group of participants.

City staff mailed 5,579 notices to owners and residents living within either the Eastside or Westside Neighborhoods requesting they take the questionnaire. Participants submitted 288 completed questionnaires.

Key themes in the questionnaire responses are summarized on the following pages.

Questionnaire Response Rates

Participant Category	Number of Responses
Property Owners	115
Residents or Tenants	15
Interested Citizens	158
Total	288



1. There is an issue, but it is limited.

When asked to mark statements with which they agree regarding demolitions, new houses and additions, most property owners in both the Eastside and Westside selected options indicating that they feel there is an issue, as illustrated in the charts below. However, they also indicate that issues generally occur only in certain areas or situations within the neighborhoods, or are limited to a small number of construction projects.

Level of Concern Among Property Owners¹ Regarding Demolitions, New Construction and Additions

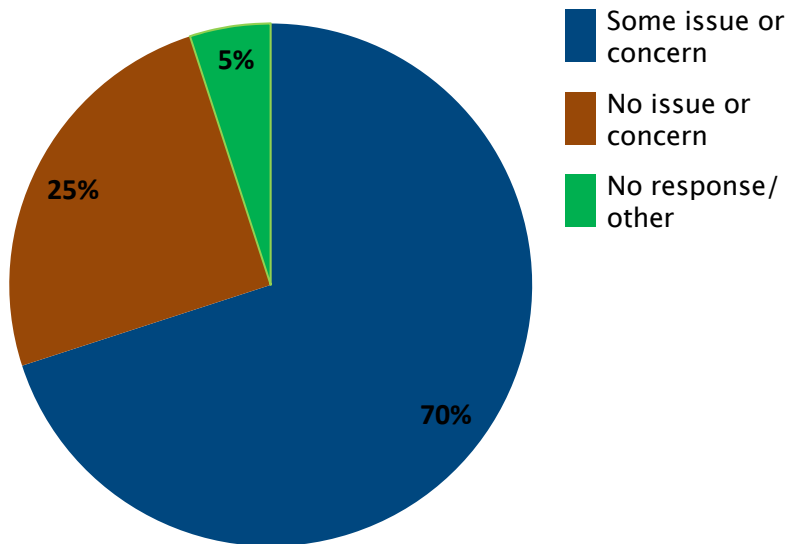

¹Responses from tenants and interested citizens indicate a similar pattern although interested citizens express a somewhat higher level of concern (only 15% indicate that they have no issue or concern with new construction).

Distribution of Property Owners with Concerns by Neighborhood

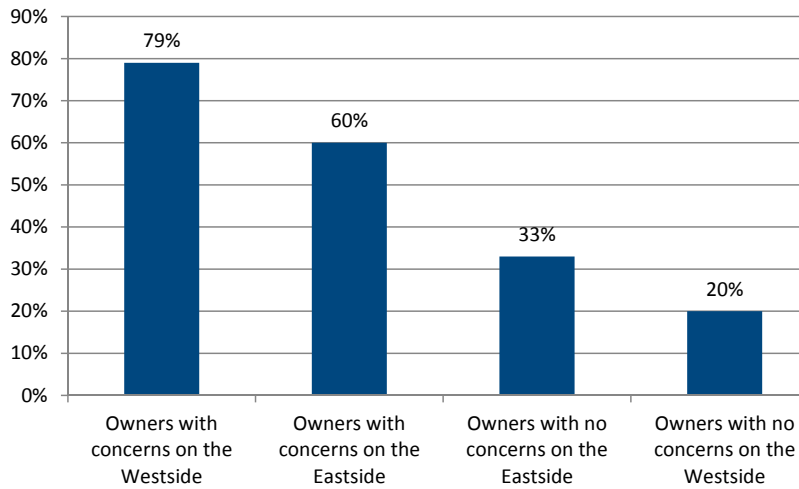

Property Owner Agreement with Statements About Demolitions, New Construction or Additions²

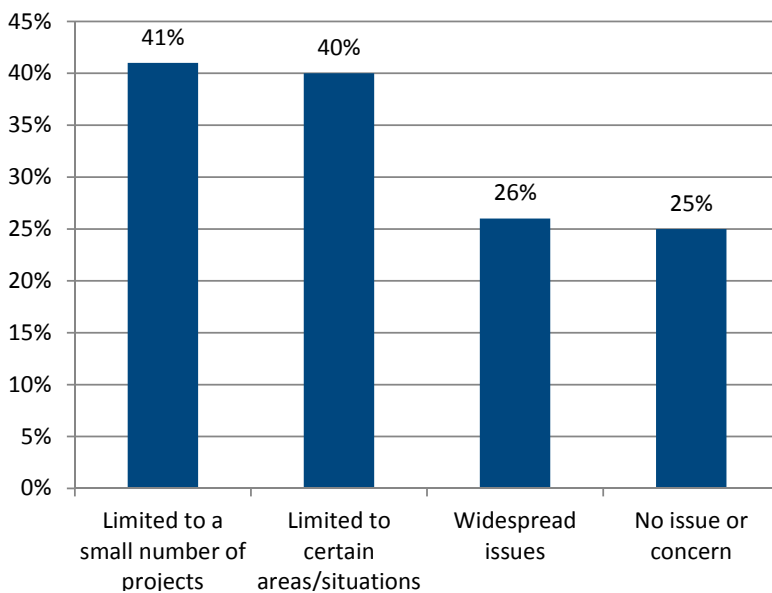

²Responses total to more than 100% because some participants indicated agreement with more than one statement (i.e., many property owners stated that their concerns with new construction were both "limited to certain areas/situations" and "limited to a small number of projects"). Property owners also cited diminished solar access, decreased socio-economic diversity, fewer "funky" properties and a number of other potentially negative aspects of neighborhood change in write-in responses.



2. Many participants feel that some new construction is positive for the neighborhoods.

Although most participants feel that there is some issue with new construction, many also indicated that some new construction and additions can benefit the neighborhoods. When asked to select potential reasons why new construction is positive, many property owners indicated that new construction can add to the eclectic evolution of the neighborhood and support families and homeownership, as illustrated in the chart below.

Property Owner Response on Potential Positive Aspects of Demolitions, New Construction or Additions¹

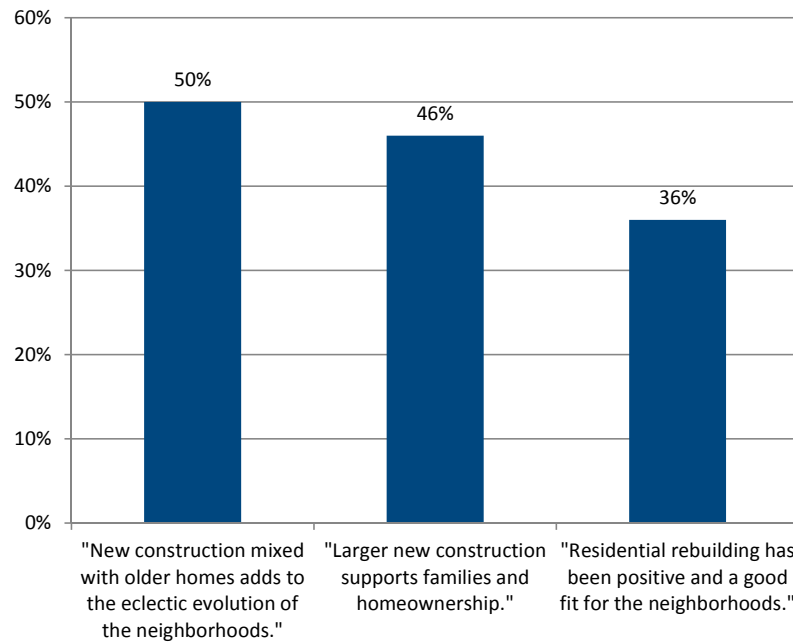

¹Responses total to more than 100% because some participants indicated agreement with more than one statement. Property owners also cited improved landscaping, increasing property values, higher rates of homeownership and a number of other potentially positive aspects of neighborhood change in write-in responses.

3. Participants expressed significant agreement on key neighborhood assets.

When asked about the five most important qualities that define the positive character of the neighborhoods, property owners most often cited walkability and proximity to Downtown as the most important neighborhood assets, as illustrated in the table below. These responses are consistent with feedback received from participants in the workshops and working groups.



Property Owner¹ Response on the Five Most Important Qualities that Define the Positive Character of the Neighborhoods

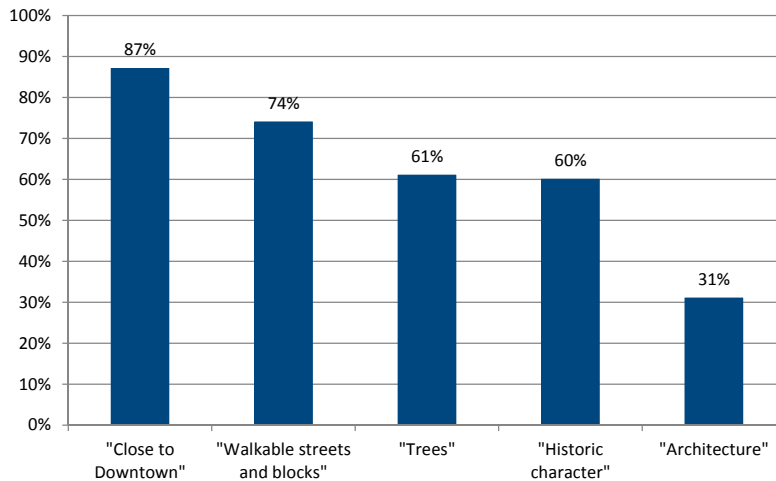

¹Responses from tenants and interested citizens indicate a similar pattern. Responses total more than 100% because participants were asked to select five positive qualities from a list of 17 potential positive qualities.

November Visual Survey

Write-in Comments

Survey participants provided a number of "write-in" comments, including:

- "This survey appears to have a built in bias toward enabling large construction and less toward fostering community and preserving neighbor character."
- "Good that it is so visual; makes it easier to think about what is being proposed."
- "This is a serious issue and much of the new construction in the last 10 years has had a very negative impact on not only the character of neighborhoods, but housing availability in these areas."
- "The design examples make it clear that many of the current criticisms to new buildings and additions in the East and West Side Neighborhoods can be alleviated through good architectural design."
- "I do not want any further regulations implemented."

An online visual survey was posted from November 1 to 11, 2012, to collect information on the effectiveness of a variety of tools that could be used to address identified issues and promote compatible development in the neighborhoods.

City staff mailed postcard survey invitations to all owners and residents in the study area. Participants were also invited via email and the City's website. Participants submitted 125 surveys.

Key themes in the visual survey responses are summarized below. Note that many of the charts add to more than 100% because participants were able to select more than one option (multiple choice).

1. There is a high level of support for education, communication and process tools.

Survey participants were generally supportive of tools to promote education and communication or address process and administrative issues. As summarized in the charts below, most participants indicated support for promoting or expanding the City's existing design assistance program, developing voluntary design guidelines and expanding notification.

Should the City consider education and communication tools in the neighborhoods?

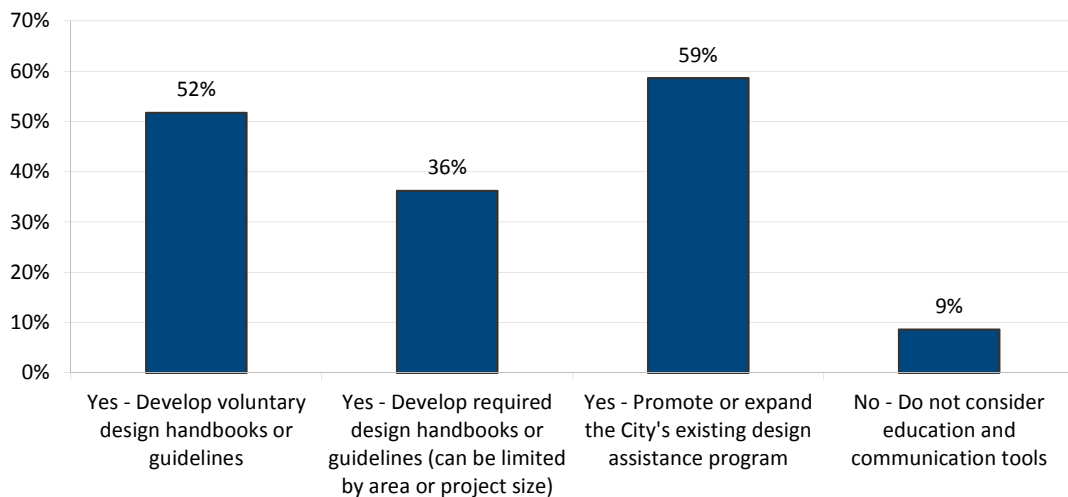

Should the City consider process and administration tools for the neighborhoods?

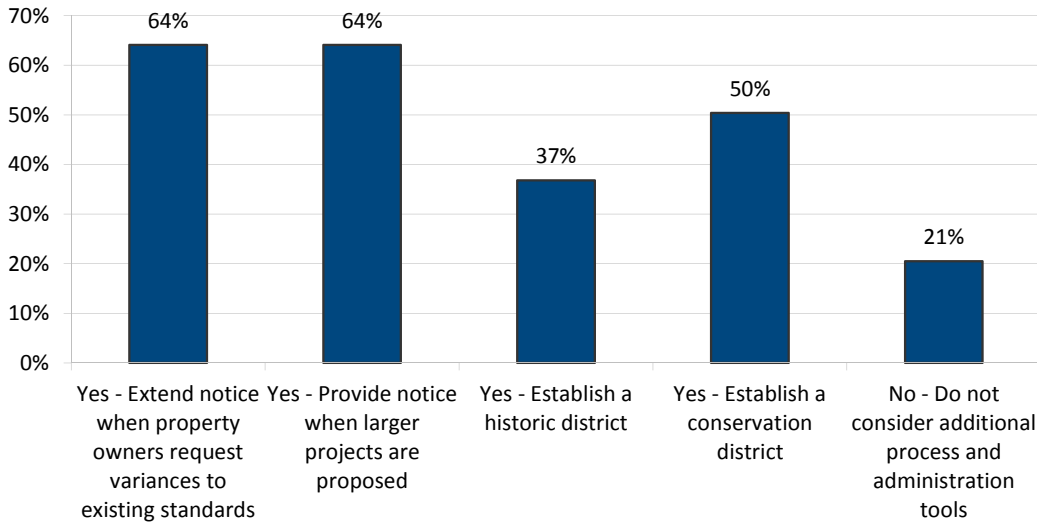

2. There is a high level of support for addressing building massing and solar access.

Survey participants also supported design tools to address identified issues with building massing and solar access. Providing a menu of options to promote varied massing for larger buildings was the most commonly selected tool. However, tools to address solar access were selected almost as often, as summarized in the chart below.

The high level of interest in addressing both building massing and solar access is reflected in strategy option 5c on page 126 (Note that this strategy option was revised to incorporate November workshop and visual survey feedback.)

Should the City consider design tools for the neighborhoods?

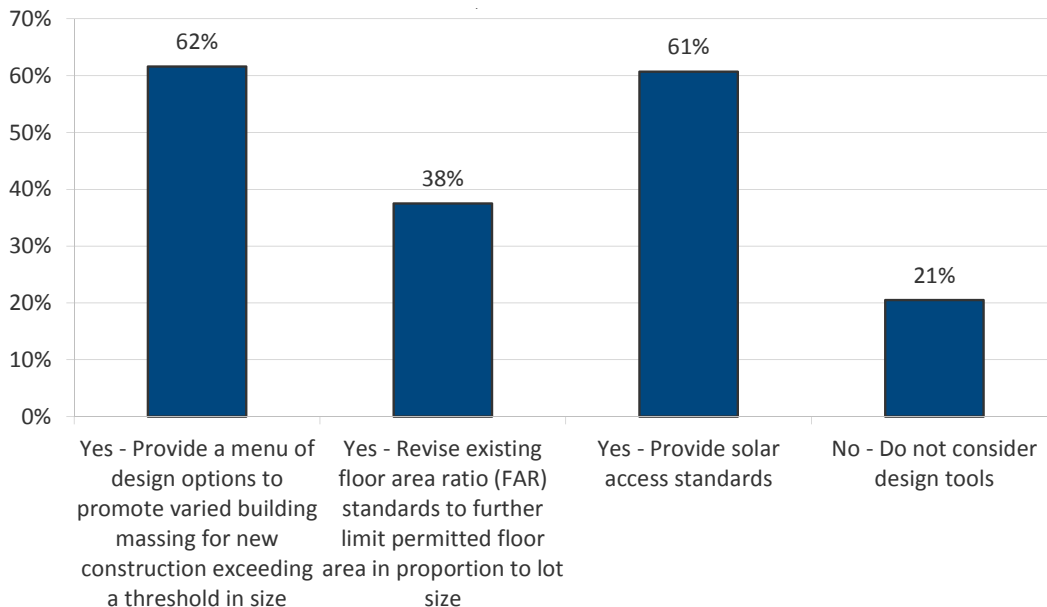

3. Some potential design scenarios are considered to be more compatible than others.

As illustrated on the next page, the visual survey tested a range of design scenarios to explore the interaction of overall building size with the character of the street front and a sidewalk, as well as overall height.

The survey responses indicate that varying building massing significantly improves perceptions of compatibility. This is especially true when the building front has substantial variations in wall planes. But, it does not completely reduce concerns about overall size. Designs that have a wide, two story front are perceived as being less compatible than those who have a varied front, even when the overall building size is greater.

Wall height at the side yard is also an important factor in compatibility. Even scenarios that contain more square footage than some others were considered more compatible with they had a lower wall height or a substantial one-story element.

4. There is support for context-sensitive application strategies.

Survey participants generally expressed support for applying tools in ways that would acknowledge the existing character and context of the neighborhoods. As summarized in the chart below, the two most commonly selected approaches were to vary application by neighborhood or character area (see "Character Areas" on page 28), or to vary application by lot size.

Note that the strategy options described on page 111 include design handbooks that would promote compatible design within each character area and design tools that would vary, to some extent, based on lot size.

If neighborhood tools are used, how should the City consider applying them?

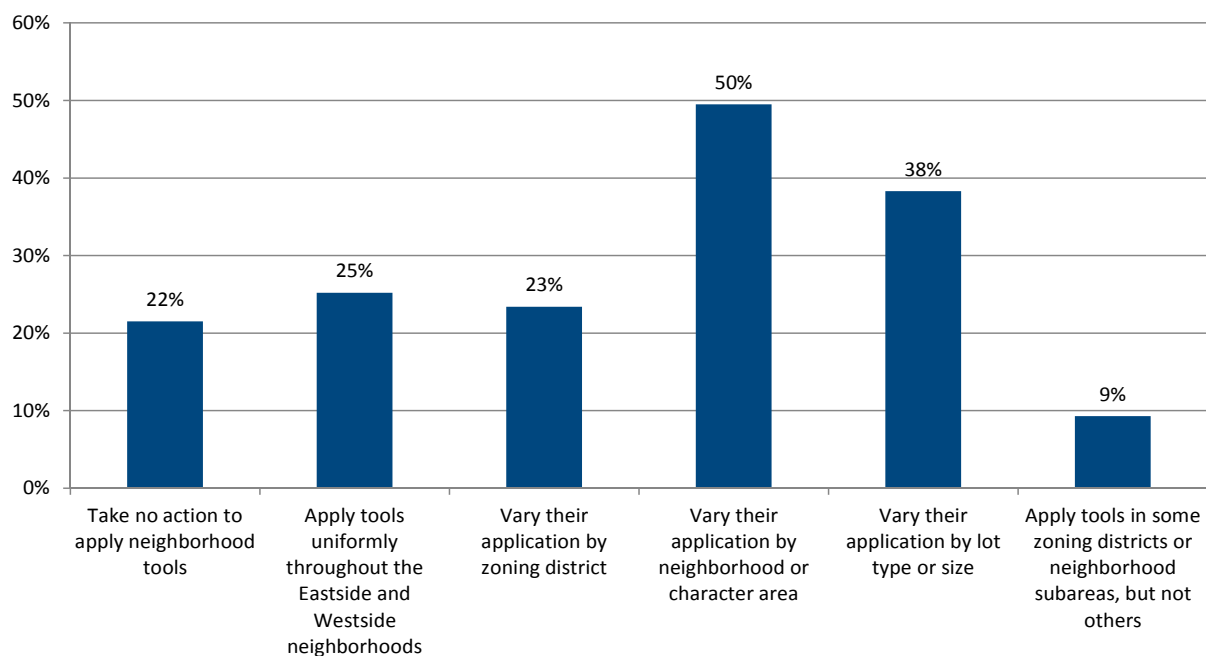

Visual Survey Design Scenarios

The visual survey presented five design scenarios modeled with simple building forms that were intentionally limited in their detail. Note that some participants felt that all of the models were too large.

Overall, survey participants felt that scenario D was the most compatible.

Scenario A

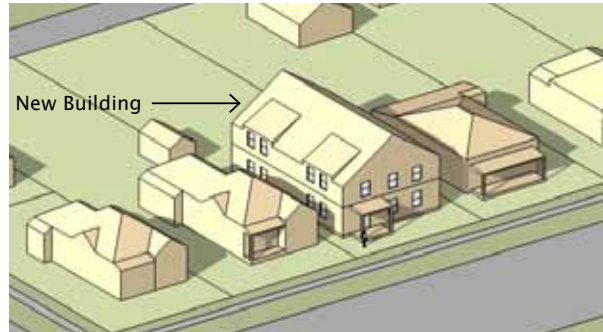

Scenario B

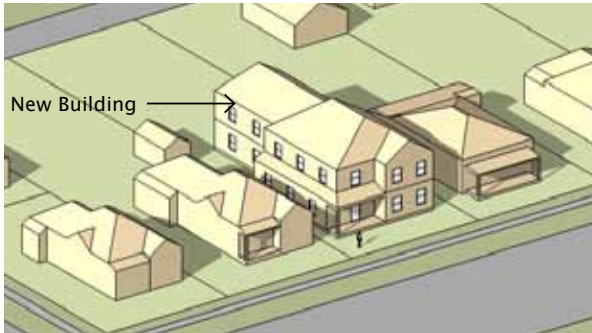

Scenario C

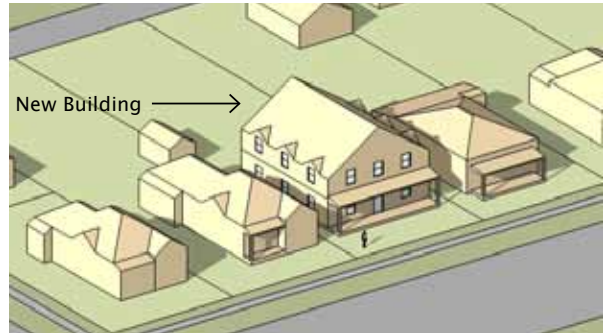

Scenario D

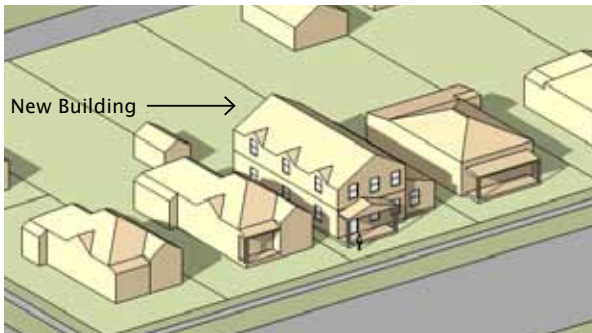

Scenario E

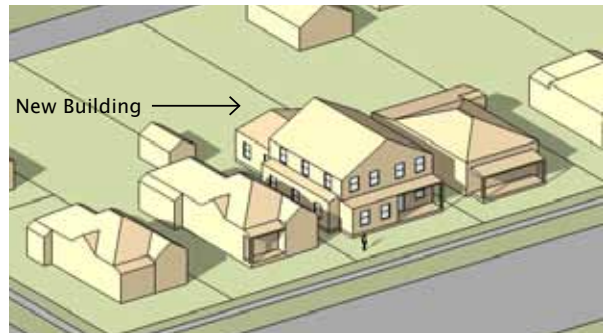

Community Comment Themes

"Diversity"



Residents often cite "diversity" as a defining characteristic of the Eastside and Westside Neighborhoods. The term is used in a variety of ways, to describe people, their beliefs and their social, economic and cultural differences. It also is used to describe variety in the built environment, such as differences in house size, period and style that occur in a limited range throughout the neighborhoods.

For some, the diversity of buildings and people is used as a rationale for accommodating new buildings that are different, and thereby add to the diversity of the area. For others, the perceived "sameness" of new construction is actually diluting the diversity of the neighborhoods.

From across the spectrum of community outreach venues, there is a consistent tone of concern that there is an issue with changes resulting from demolitions and new construction. However, this is not a universally held viewpoint. Some people, in all outreach venues, have said there is not a problem, or that no new regulatory changes should be made. These concerns are important to consider, and identifying ways to respond to them is still an area of exploration.

Reviewing research related to existing conditions and considering the comments received in neighborhood workshops, working groups and questionnaires/surveys, some general themes emerge:

1. The neighborhoods are highly valued.

This is perhaps stating the obvious, but a strong point of agreement is the belief that the Eastside and Westside Neighborhoods are special. Many of the reasons for saying so are also broadly recognized, even among those who disagree about the character and impacts of new construction. This is reflected in the passion with which residents and property owners engage in debates about the future of their neighborhoods.

2. Key features that define the neighborhoods are broadly recognized.

The valued characteristics of these neighborhoods focus on convenient location, a walking-oriented environment and diversity. The main themes of neighborhood character can be grouped thus:

- **Proximity to amenities.** Almost universally, people cite the convenient access to downtown, to schools and parks, to grocery stores, CSU and other services as “top of mind” features.
- **Livable Streets.** Tree-lined streets, continuity of pedestrian and bicycle routes and a walkable scale to each block are features people note. Homes that face the street, and signal a connection to it with porches and other friendly features contribute to this aspect.
- **Sense of Community.** These broad, somewhat intangible characteristics are those that have attracted people to these neighborhoods for decades.
- **Diversity.** “Diversity” is a fundamental feature of these neighborhoods, in terms of people and the built environment.



3. Use of key design tools can help buildings fit into the neighborhoods.

Although design diversity is a key feature of the neighborhoods, it is also recognized that there are key building design tools that designers can use to make new buildings more compatible with existing neighborhood character in certain contexts. Such tools generally address basic mass and scale relationships between properties as well as preservation of open space and solar access.

4. Living with change is a challenge.

Residents are struggling to grasp the nature of change in their neighborhoods. Most recognize that change will occur, and believe that it should, but many hope that this change will not completely transform the place where they live.

Neighborhood Objectives and Issues

Community comment generated by the public process for the Eastside and Westside Neighborhood Character Study has helped identify and clarify overall objectives for the neighborhoods. They are:

1. Promote awareness of what makes the neighborhoods great
2. Promote compatible redevelopment
3. Maintain a sense of community
4. Encourage communication among neighbors
5. Preserve flexibility for change and reinvestment
6. Acknowledge economic impacts

The public process has also identified a number of issues with ongoing changes that may negatively impact existing residents and the unique character and context of the neighborhoods. They are:

- A. New construction that appears to be overly large in relation to its context
- B. Building walls that appear to loom over neighbors
- C. Reduced solar access/shading issues
- D. Incompatible design features
- E. Loss of older/more affordable houses
- F. Loss of green space and mature trees

The neighborhood objectives and issues listed above inform an evaluation of the potential tools described in Part 3, Potential Tools, and provide a foundation for the strategy options described in Part 4, Strategy. It is important to note that some participants in the public process indicated that they do not believe there are issues with new construction and additions in the neighborhoods and feel that new tools should not be considered.

Part 3

Potential Tools

A number of potential tools could be used to address neighborhood issues and objectives identified during the public process. Most tools could be applied as voluntary policies, incentivized, or implemented as design standards (zoning requirements). They may be grouped into three primary categories:

1. Education and Communication

These tools focus on providing information to strengthen skills and build awareness of, and support for, neighborhood character and compatibility.

2. Process and Administration

These tools include neighborhood planning processes, as well as the procedures for review and permitting of new construction and additions in the neighborhoods.

3. Design Tools

These tools provide quantitative code requirements, or "design standards" for development such as maximum height and minimum setbacks.

This part of the report outlines tools in each category that could be used to address neighborhood issues and objectives. Tools suggested for formal consideration are described in Part 4: "Strategy Options" on page 111.



Part 3 Contents

Education and Communication	86
Design Handbooks/Guidelines	86
Neighborhood Character Descriptions	88
Awards Programs	88
Design Assistance	88
Process and Administration	89
Public Notice and Neighborhood Comment...	89
Neighborhood Plans	90
Historic and Conservation Districts	91
Design Tools	93
Neighborhood Level Tools	93
Site Level Tools	94
Building Level Tools	99
Potential Application Strategies	108



Design handbooks and guidelines may be used to support a design review process that provides an additional level of detail and allows for a high level of context sensitivity in the design approval process.

Education and Communication

These tools focus on providing information to strengthen skills and build awareness of, and support for, neighborhood character and compatibility. They may also provide channels for communication among neighbors, builders and the City.

Design Handbooks/Guidelines

Design handbooks and guidelines provide information to promote compatible, context-sensitive, design. They may cross reference information about context or neighborhood character as described on page 88.

Design handbooks (or pattern books) typically show how various building components, such as roof forms, porches and architectural details, can be combined to yield designs that will fit with the neighborhoods. Design guidelines are similar, but often provide more specific detail and direction and acknowledge an interactive dynamic between many design variables.

Some interpretation will generally be needed to consider the interaction between guidelines and whether a specific design solution meets the overall intent.

Design guidelines may be used in three ways:

- **Voluntary:** Residents, designers and builders use design handbooks or guidelines to inform compatible design, but compliance with the intent of the handbooks or guidelines is not required.
- **Advisory:** Designs are reviewed by a board or commission, but applicants are not required to comply with board suggestions. This approach is sometimes applied where a defined threshold is exceeded, such as above a specific floor area ratio (FAR).
- **Mandatory:** Designs are reviewed by a board or commission to determine whether designs meet the intent of the handbooks or guidelines. Applicants are required to comply with board requests to obtain approval.

Advantages of Design Guidelines:

- Helps ensure that additions and new construction are context-appropriate
- Allows for flexible design solutions
- May address a more detailed level of design than regulations can

Potential Disadvantages of Design Guidelines:

- Requires interpretation
- May not provide predictable outcomes
- May not always address issues if voluntary

Existing Design Guidelines: In 1996 a voluntary Design Guidelines document was developed but is no longer distributed.

Sample Design Guideline

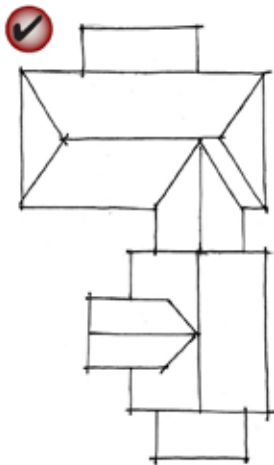

Subdividing the mass of a larger building into smaller “modules” that are similar in size to buildings seen traditionally is encouraged.

3.24 Construct a new structure to reflect the mass and scale of historic residential structures in the area.

Appropriate

- Subdivide the mass of a larger building into smaller “modules” that are similar in size to buildings seen traditionally.
- Design building features to incorporate traditional dimensions. Wall plate heights, window and door head heights and other vertical proportions should match the appropriate scale of the period.

Design guidelines for established residential areas in the City of Galveston encourage new construction and additions with compatible mass and scale.

Neighborhood Character Descriptions

Neighborhood character descriptions establish a clear understanding of the characteristics of an area that residents value. This includes the basic physical framework of a neighborhood, defines similarities of design in terms of building and site design and a description of the degree of diversity that appears. This analysis can help the community determine the degree of sensitivity that each area has to change, and can assist with the application of design handbooks or guidelines as described on page 86.

Existing Neighborhood Character Descriptions: Information about neighborhood character is provided in Part 1: "Neighborhood Profile" on page 7. This includes an identification of varied subareas or "character areas" throughout the neighborhoods as described on page 28. Older neighborhood character descriptions are provided in the 1996 design guidelines, as well as the 1980s neighborhood plans.

Awards Programs

These are special programs for the recognition of highly compatible projects that can stimulate investment in properties as well as encourage owners to maintain neighborhood compatibility.

Existing Programs: There are no existing awards programs in the neighborhoods.

Design Assistance

These are special programs offered through the City which give owners a certain amount of design assistance, often in the form of a design professional's time.

Existing Program: In late 2011, the City started a design assistance program that aims to enhance neighborhood compatibility through the assistance of experienced professionals with success in context-sensitive design. Through October of 2012, the program has been used to assist with 25 projects citywide. 4 of these projects were in the Eastside neighborhood and 6 were in the Westside neighborhood.

Participants in the public process for this study noted that many residents are not aware of the existing design assistance program.

Process and Administration

These tools include neighborhood planning processes, as well as the procedures for review and permitting of new construction and additions in the neighborhoods. They may also address enforcement programs.

Public Notice and Neighborhood Comment

Requiring public notice of a proposed project may inform neighbors of a planned demolition or new construction. Such a requirement may be combined with a neighborhood comment program that provides an opportunity for neighbors to comment on, or discuss plans.

Existing Requirements: The City currently requires mailed notice to property owners within 150' of a property where a zoning variance is requested. An existing demolition/alteration review process also provides notification of potential demolition of buildings or structures 50 years old, or older (See <http://www.fcgov.com/historicpreservation/review.php> for more information). However, there is not a formal process for demolition of newer structures or notification of plans for new construction.

Neighborhood Plans

Many communities use neighborhood plans to guide development within an established context. Such plans provide a future vision and can guide development of other, more specific tools, such as design handbooks and guidelines. They may also be used in reviewing projects, and especially in considering any variances that may be requested. In some cases, in order to issue a variance the review body must find that the proposed action is in compliance with the neighborhood plan. A neighborhood plan could also provide a blueprint for streetscape design and other improvements on the public realm.

Advantages of a Neighborhood Plan:

- Provides specific policies, goals and objectives for future development at the neighborhood level
- Provides a fine-tuned level of guidance for public improvements (parks, paths, streetscape, etc.)
- May guide development of context sensitive tools to promote desired design and development patterns

Potential Disadvantages of Neighborhood Plans:

- May be costly and time consuming
- May not address current issues in a timely manner
- May not be as strong as other regulations

Existing Plans: In the late 1980s, the first Neighborhood Plans were adopted for the Eastside and Westside Neighborhoods, establishing a policy basis for protecting the character of the neighborhoods. Updates to the neighborhood plans for the Eastside and Westside are currently on the City's work program for 2014.

Historic and Conservation Districts

Historic Districts

A historic district designation focuses on preserving the significance of all of the historic structures that combine to create a sense of time and place, as well as to assure that new construction is compatible with this context. Historic districts are established under local zoning regulations, within the framework of appropriate state enabling legislation.

The historic designation can be used for individual properties of historic significance, and neighborhoods that meet the criteria for listing as districts. This tool may also be used to protect certain significant properties from demolition.

Advantages of Historic Districts:

- Preserves the historic character and integrity of places of significance.

Potential Disadvantages of Historic Districts:

- Can create a regulatory burden if overly complex to administer

Existing Historic Districts: Portions of the Laurel School National Register Historic District are located in the study area. However, special preservation regulations apply only to locally-designated historic districts (the Old Town commercial district is currently the only locally-designated historic district in the city).

Historic and Conservation District Goals

The following goals typically motivate the creation of a Historic District:

- To preserve the integrity of all historic resources that contribute to the district
- To assure that the sense of time and place is maintained, through compatible new construction

The following goals typically motivate the creation of a Conservation District:

- To maintain neighborhood character
- To enhance livability
- To attract investment
- To promote community sustainability
- To preserve historic resources, if they exist in the area, as individual landmarks

Conservation Districts

The conservation district is a specialized form of zoning overlay which is specifically established to protect existing character. Conservation districts use broader criteria than historic districts, but still focus on respecting the established context. A typical conservation district focuses on new construction, large additions and site design; minor alterations are not typically reviewed.

A conservation district is used as an alternative to historic district designation for a variety of reasons, including:

- The area does not contain a sufficient percentage of historic resources,
- Or, politically, support does not exist for historic district designation,
- Or, the government is concerned about the administrative burden of adding more historic properties to the city's preservation review responsibilities.

Historic buildings also can be embedded in a conservation district. These are individually landmarked, and conventional preservation protections and incentives apply to them.

Advantages of a Conservation District:

- Less administrative burden than historic districts.
- A wider range of construction techniques may be available, assuring economical options.
- Design guidelines are generally more broad, providing flexibility in approaches.
- Political support may not exist for designating a historic district, while protecting livability of neighborhoods may enjoy wide support.

Potential Disadvantages of Conservation Districts:

- May not protect the historic integrity of a neighborhood
- May not maintain significant character-defining features on historic structures

Existing Conservation Districts: Conservation districts are not currently used in the N-C-M and N-C-L districts.

Design Tools

These tools provide quantitative code requirements, or "design standards" for development, such as maximum height and minimum setbacks.

Neighborhood Level Tools

Tools such as streetscape design standards and lot size standards help shape the public realm of the neighborhood and the overall density of development.

Streetscape Design Standards

The character of a neighborhood is substantially influenced by the design of the public realm. Standards for street trees, the use of planting strips along the curb, and the placement and materials of sidewalks are basic features. Street lights and other utilities also affect character.

Advantages of Streetscape Design Standards:

- Can support a cohesive street character

Potential Disadvantages of Streetscape Design Standards:

- May limit individuality of front yard designs

Existing Regulations: No streetscape design standards are in place in the neighborhoods.

Lot Size Standards

Lot size standards determine density and influence the general character of single-family neighborhoods. They generally set a minimum size for lots but may also set a maximum. Lots may not be subdivided if a resulting lot would be smaller than the minimum standard. In addition, existing lots that are smaller than the minimum standard may be considered as "non-standard" and require variances to obtain permits for additions and new construction.

Advantages of Lot Size Standards:

- In combination with building size and number regulations, can help maintain density

Potential Disadvantages of Lot Size Standards:

- Can limit the ability to subdivide large lots

Existing Regulations: Currently minimum lot size standards of 5,000 s.f. in N-C-M and 6,000 s.f. in N-C-L are in place.

Building Coverage Diagram

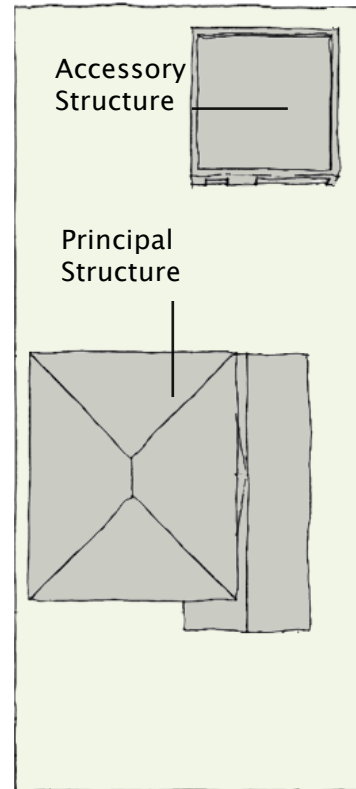

Building Coverage Calculation Example

Lot Size:	6,000 SF
Area Covered by Principal:	1,300 SF
Area Covered by Accessory:	500 SF
Total Area Covered:	1,800 SF

$$1,800 / 6,000 = 30\% \text{ Total Coverage}$$

Site Level Tools

Tools such as lot coverage, building coverage, open space and landscaping standards help preserve and promote an existing or desired character within and among individual lots. They may determine where buildings are located relative to the street and sidewalk and how much green space is visible from the street or separates structures from each other.

Building Coverage

Building coverage standards establish the maximum percentage of a lot surface that may be covered by structures. Additional elements are sometimes excluded (in part or in whole) from building coverage to provide additional flexibility or to promote specific design elements. These may include:

- Roof overhangs
- Accessory structures
- Roofed front porches
- Any deck or patio areas that are not roofed
- Gazebos that are not enclosed on more than two sides

Advantages of Building Coverage Standards:

- Helps maintain open space
- Helps preserve side and rear yard areas
- Mitigates privacy impacts by discouraging larger structures from extending substantially into the rear yard
- Can be used to provide an incentive for front porches or detached garages/accessory structures

Potential Disadvantages of Building Coverage Standards:

- Could encourage taller structures if not combined with specific height or floor area ratio standards

Existing Regulations: There is no building coverage standard currently in use.

Lot Coverage Standards

Lot coverage standards may dictate the maximum percentage of a lot surface that can be covered by built areas such as buildings or paved areas. Often, any impervious surface area (that which sheds water such as building roofs, patios, driveways and walkways) is considered as lot coverage.

Advantages of Lot Coverage or Standards:

- Helps maintain green space

Potential Disadvantages of Lot Coverage Standards:

- Could encourage taller structures (to allow for larger driveways, patios, etc.) if not combined with specific height or floor area ratio standards
- Limits on all hard surfaces would not have as significant an effect on building form as building coverage standards

Existing Regulations: A maximum hardscape area of 40% in the front of a lot is currently used in both the N-C-M and N-C-L zone districts.

Open Space Standards

Open space standards may generally be described as the inverse of lot coverage standards. That is, they specify a minimum amount of open space rather than a maximum area that may be covered by buildings or other surfaces and structures.

Open space standards may differ from lot coverage standards when specific standards are set for the quality or location of the required open space. They are also more likely to be applied at a neighborhood, or framework, level, specifying the minimum amount of combined open space for a larger development.

Existing Regulations: There is no open space standard currently in use. However, where a secondary dwelling is permitted it is required to have a separate yard of at least 120 square feet.

Lot Coverage Diagram

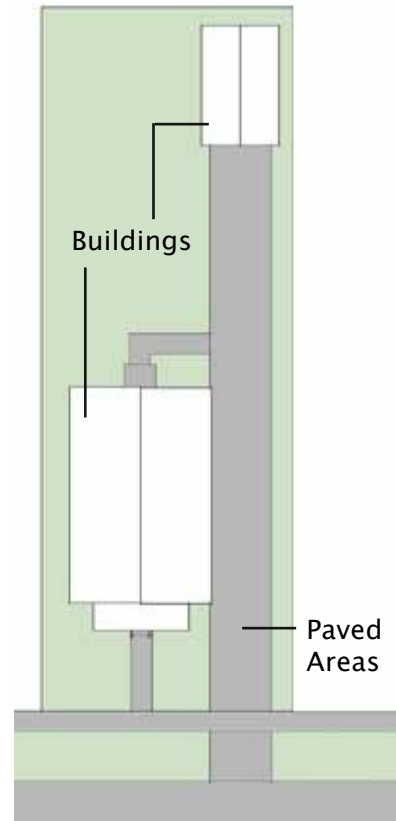

Lot coverage standards dictate a maximum percentage of a lot surface that can be covered, such as by buildings or paved areas. The illustration above shows a lot coverage of 40%.

Landscape Buffer Diagram

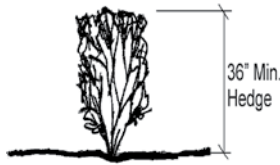
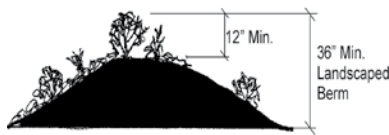
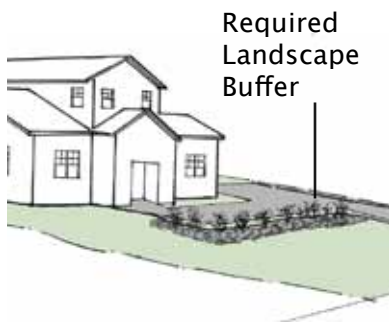

Landscape buffering standards may be used to screen certain areas from the street or a neighboring property. They may include a planting height requirement or an allowance for landscaped berms.

Landscape Buffering Standards

Landscape buffering standards require vegetation to screen incompatible structures and uses. Most frequently used where commercial or industrial uses abut single-family residential uses, landscape buffering may have a role in protecting the privacy of side and rear yards or in screening parking areas from neighbors or the street.

Landscape buffering is usually described as a planting area of a specified width along the property line. Detailed requirements for the plant material ensure that adequate buffering occurs. Some buffers also include a requirement for walls or fences.

Advantages of Landscape Buffering Standards:

- Evergreen vegetation provides a visual and functional screen between new development and existing homes.
- Additional vegetation has a beneficial effect on air quality and helps reduce the heat island effect of paved areas.

Potential Disadvantages of Landscape Buffering Standards:

- Landscape buffering could limit the ability to provide adequate solar access if placed in some locations.
- Most current landscape buffering requirements do not buffer "like from like," meaning single-family homes next to other single-family homes, because these are usually considered compatible enough not to require a buffer.
- May be difficult to enforce

Existing Regulations: There are no landscape buffering standards currently in use.

Landscape Volume Ratio (LVR) Standards

LVR measures soft vegetative volume. In mature residential communities this can be as important as building volume because lots are likely covered with mature landscaping. In many older neighborhoods, landscape volume may be larger than building volume. A tear down is likely to result in a loss of mature vegetation. The LVR provides a means of measuring this.

Advantages of Landscape Volume Ratio Standards:

- Unlike most buffer systems, LVR is sensitive to the actual height and volume of both existing and proposed trees and other vegetation.
- Relates amount of vegetation on the site to the size of the lot (large lots will require more vegetation to reach the same ratio).

Potential Disadvantages of Landscape Volume Ratio Standards:

- Difficult to calculate and enforce
- Volume ratio does not specify placement of vegetation to serve as a screen.
- Is not as effective in the winter when deciduous trees lose their leaves

Existing Regulations: Landscape volume ratio standards are not currently used.

Setback Diagram

Side and Rear Setbacks for Accessory Structure

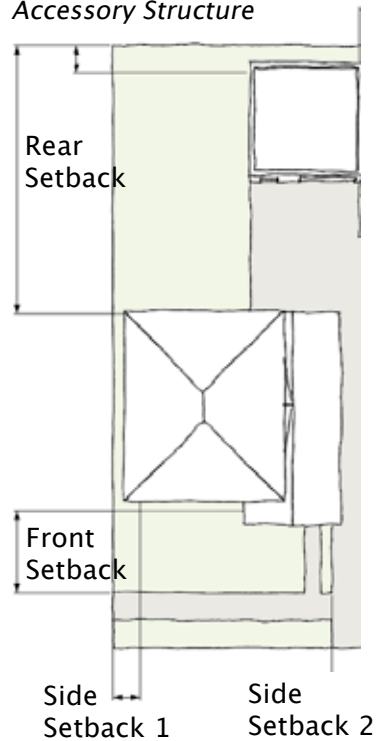

Setback Standards

Setback standards limit how close buildings may be placed to the front, sides or rear of a lot. The setback is usually calculated as the distance from the property line to the edge of the nearest building. Taken together, front, side and rear setback standards define the area of the lot where structures may be built.

Advantages of Setback Standards:

- Front setbacks help maintain a continuous pattern of open space along a block.
- Side and rear setback standards can protect privacy (especially when new construction involves a two-story building) by ensuring that buildings on adjoining lots are separated by a minimum distance.
- Incentives can also be included in setback standards to promote desirable design elements such as front porches or buildings that step down towards their neighbors (i.e. allowing front porches to encroach into the setback or providing different side setback standards for one and two-story building elements).

Potential Disadvantages of Setback Standards:

- In areas with varied setbacks, increased setback standards could cause some structures to become non-standard.

Existing Regulations: Front, side and rear setback standards for both the primary and accessory structures are currently used within both the N-C-M and N-C-L districts.

Building Level Tools

“Building level” tools govern the mass, scale and general design characteristics of buildings on individual lots.

Floor Area Ratio (FAR) Standards

Floor area ratio standards limit the total square footage of all structures on a lot. FAR is generally expressed as two decimal digits, calculated by dividing the total building square footage by the total lot square footage.

FAR standards do not alter the three-dimensional building envelope in which structures may be built, but will generally make it difficult or impossible to build a structure that fills the entire envelope. When the FAR is set at a level that is less than what otherwise could be constructed within setback, height and building coverage limits, then there is the opportunity for variation in building form. That is, different design solutions, with different massing arrangements, can occur.

Additional elements are sometimes excluded (in part or in whole) from FAR to provide additional flexibility or to promote specific design elements. These may include:

- Attic space
- Accessory structures
- Roofed porches

Advantages of FAR Standards:

- Directly relates the size of structures to the size of the lot
- Relatively easy to understand and calculate
- Can be combined with lot coverage and height limits to break down the overall scale of structures
- Can be used to provide an incentive for front porches or detached garages and accessory structures

FAR Diagrams

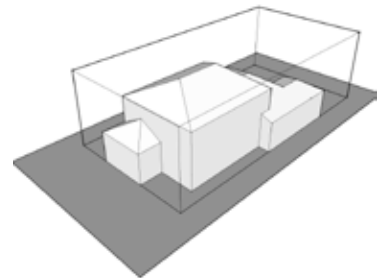
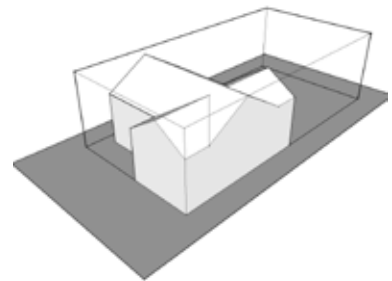
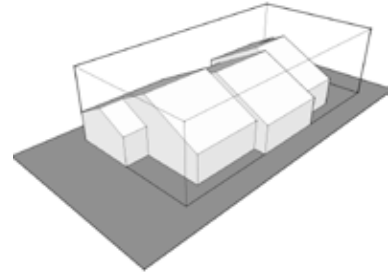

When the FAR is set at a level that is less than what otherwise could be constructed within setback, height and building coverage limits, then there is the opportunity for variation in building form. That is, different design solutions with different massing arrangements can occur. All of the structures illustrated above have a floor area ratio of 0.40.

FAR Diagram

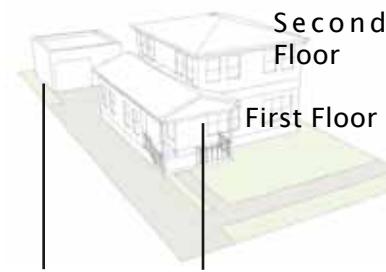

Accessory Structure Principal Structure

Lot Size: 6,000 SF
Principal 1st Floor
Area: 1,300 SF
Principal 2nd Floor
Area: 900 SF
Accessory Floor
Area: 500 SF
Total Floor Area: 2,700 SF

$$2,700 / 6,000 = 0.45 \text{ FAR}$$

Potential Disadvantages of FAR Standards:

- Could permit inappropriately tall or box-like structures when not combined with other standards and guidelines
- Could permit inappropriately large structures on large lots
- Could constrain the building potential of small lots

Existing Standards: The City currently specifies a minimum lot area in relation to the total floor area of buildings on the lot. This standard creates a de facto maximum FAR for the lot (0.40 in the N-C-L district and 0.5 in the N-C-M district). In addition, there is a separate FAR for the rear half of a lot (0.33 in the N-C-M district and 0.25 in the N-C-L district). Existing FAR standards include the floor area of the primary structure as well as the floor area of any accessory structures that are larger than 120 square feet.

Overall Height

Overall building height standards dictate the maximum height a building may reach.

Advantages of Height Standards:

- Helps ensure that structures do not loom over their neighbors
- Relatively easy to understand and calculate
- Can be used to provide an incentive for specific roof forms that are consistent with a specific neighborhood character or tradition (i.e., height may be calculated to the mid-point of a sloped roof to encourage pitched roof forms).

Potential Disadvantages of Height Standards:

- Could permit inappropriately tall structures near neighbors unless combined with other standards
- Can create confusion if methods of measurements are inconsistent

Existing Regulations: The current maximum allowable building height is determined by side setbacks, sidewall height, a two-story maximum, and a maximum roof pitch of 12:12. There is no maximum number for height measured in feet for primary structures. However, there is a maximum height for accessory structures of 24 feet. The maximum sidewall height currently does not include any alterations to grade, which can result in a higher relative height for projects using a raised grade as compared to those which do not.

Bulk Plane Diagram

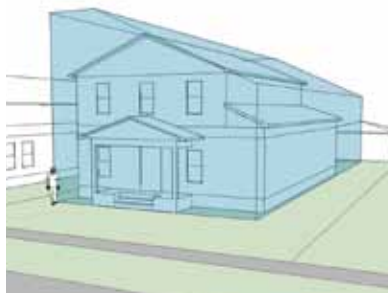

Bulk planes primarily serve to shape the three dimensional "envelope" in which a building can be built.

Bulk Plane Standards

Bulk plane standards shape the maximum permitted three-dimensional building envelope by limiting the height and mass of building elements on different parts of a lot. A bulk plane generally rises at a defined angle from the front, side or rear property line(s) or from the front, side or rear setback(s). It can begin at ground level, or at a predetermined point above ground level, and continue to rise toward the center of the lot until it meets the overall height limit or intersects a bulk plane rising from another side of the lot. Bulk planes ensure that taller portions of a structure are positioned in the center of the lot, rather than immediately adjacent to neighbors.

Building elements often exempted from bulk plane standards:

- Chimneys
- Dormers (often limited in size)
- Solar panels

Advantages of Bulk Plane Standards:

- Restricts taller or more massive building elements to certain portions of a lot
- Helps reduce the potential of tall walls or massive structures to adversely affect their neighbors
- Can be combined with lot coverage, FAR and/or CCR standards to mitigate mass and scale impacts while encouraging creative design solutions

Potential Disadvantages of Bulk Plane Standards:

- May not support existing conditions in areas where some traditional structures have tall exterior walls
- Can be difficult to visualize or understand
- May encourage longer buildings where very narrow lots occur

Existing Regulations: Bulk plane standards are not explicitly used in the project area. However, a *de facto* bulk plane is used which specifies a maximum building wall height based on distance from the side setback.

Solar Access Standards

Solar access standards limit the amount of shadow a building can cast on a neighboring property. The areas for which solar access is protected can vary by application, and include:

- Yards,
- Rooftops, and/or
- South-facing walls, or portions thereof.

Typically a certain amount of solar access is designated for protection for a certain time period on the winter solstice. Often this is defined by the amount of shadow that would be cast by a hypothetical fence of a certain height on that area.

Advantages of Solar Access Standards:

- Supports the use of both active and passive strategies for lighting, heating and energy generation
- Helps maintain the ability to garden in a yard
- Can be combined with other standards to mitigate mass and scale impacts while encouraging creative design solutions

Potential Disadvantages of Solar Access Standards:

- May be more restrictive on certain lot conditions than on others
- Can sometimes be difficult to visualize or understand
- May encourage a stepped building form depending on application of standards
- May encourage larger building mass along a southern property line

Existing Standards: The City does not currently have solar access standards that apply in established residential neighborhoods such as the Eastside and Westside. Solar access standards are, however, applied to new residential developments. Such standards prohibit casting shadow onto structures on adjacent properties greater than the shadow which would be cast by a 25' hypothetical wall located along the property lines of the project between the hours of 9:00 am and 3:00 pm, MST, on December 21.

Solar Access Diagram

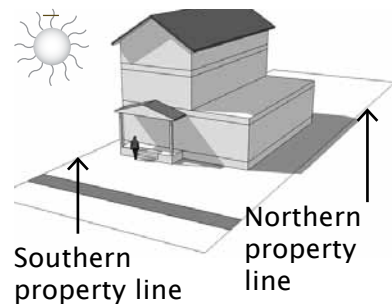

Solar access standards limit the amount of shadow that a building can cast on a neighboring property. In this example the building mass is pushed to the south side of the property to maintain solar access for the neighbor to the north.

Articulation and Wall Sculpting

Articulation standards further refine the perception of building scale by “sculpting” the exterior of buildings. The primary objective is to reduce the perceived mass of a building by dividing it into smaller components, or “modules.” Articulation can be required in several different ways or can be required to include a certain number of methods.

One Story Element

A one-story porch or other element can be required along one or more building facades. Typically this would be required on the street front of a building in order to help reduce the apparent mass of the structure from the street. As an alternative to requiring a one-story element, an incentive can also be included in FAR or building coverage standards to encourage one-story front porch elements.

Roof Ridge Articulation

A maximum length can be established for the ridge line of a roof before an offset must occur. This can help minimize the perceived mass of the roof area.

Wall Sculpting/Wall Height and Length

Wall length and height standards may be combined to help sculpt building forms and discourage overly large or box-like shapes. Wall length standards set a maximum length for the wall planes of exterior building walls before they must jog or incorporate an offset. Wall height standards set a maximum permitted height for exterior building walls before they must step back. Wall heights are usually measured from either grade or the first finished floor to the highest horizontal framing member, or wall plate, that intersects the wall. This is usually the point at which the roof eave meets the wall.

Wall height standards are often tied to setbacks to help ensure that taller or more massive building elements are located away from the edges of a lot. Such wall height standards can shape the permitted building envelope in a way that is similar to a bulk plane standard. Wall length standards may be tied to wall height to restrict the length of two-story walls while allowing longer walls if they are one story in height.

Advantages of Articulation and Wall Sculpting Standards:

- Reduces the perceived mass and scale of structures
- Helps ensure that the mass of larger infill structures is broken up to reflect the size of traditional structures
- Encourages division of building mass into modules
- Facilitates varying the setbacks of building walls along the sides of properties
- Helps mitigate the impacts of large side walls “looming” over neighbors

Potential Disadvantages of Articulation and Wall Sculpting Standards:

- May not support existing conditions in areas where traditional structures have tall or long walls
- May not support some desired interior floor plan layouts

Existing Regulations: Specific articulation and wall sculpting standards are not currently used within the neighborhoods.

Articulation and Wall Sculpting Diagram

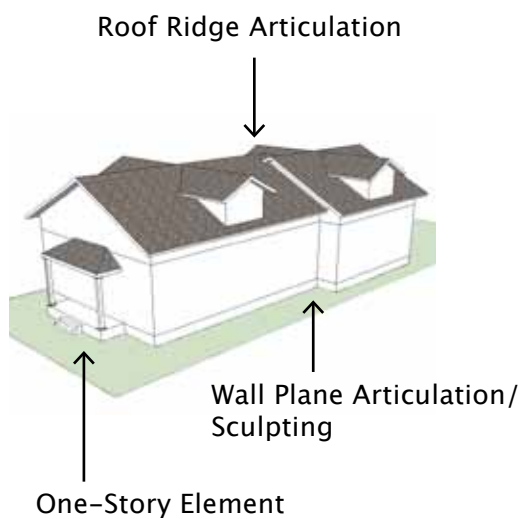

Alternative Wall Articulation Options

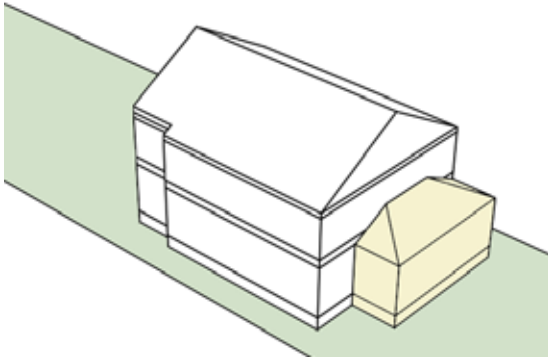

Front wall with one story element

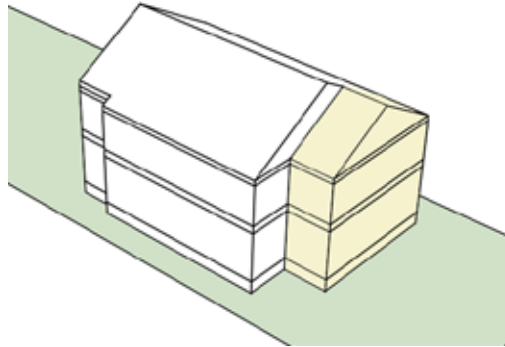

Front wall with offset

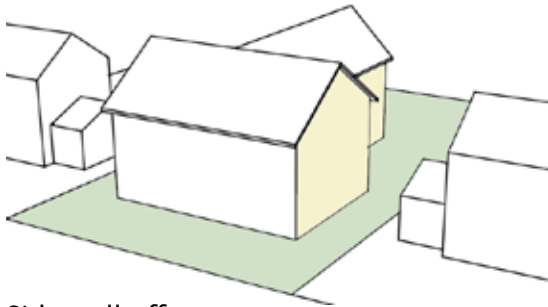

Side wall offset

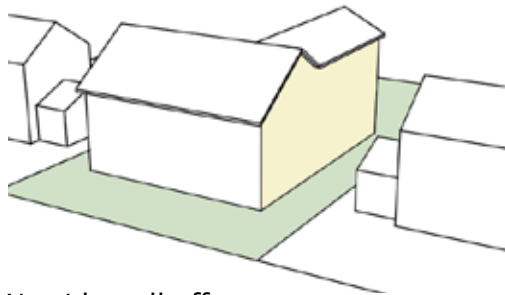

No side wall offset

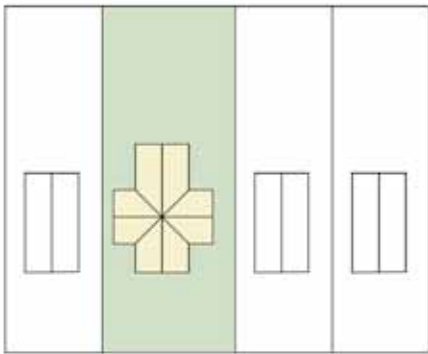

Maximum front wall plane

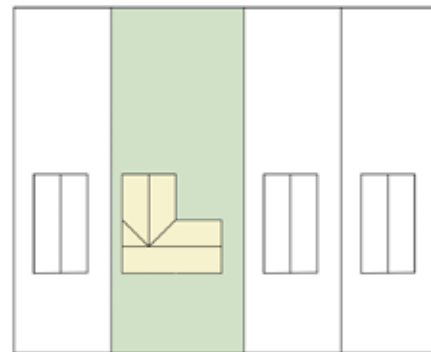

No maximum front wall plane

Some articulation standards provide a "menu" of choices to achieve variety in massing.

Cubic Content Ratio (CCR) Standards

Cubic Content Ratio standards limit the total volume of all structures on a lot. CCR is generally expressed as a whole number with two decimal digits. It is calculated by multiplying the maximum exterior height, width and depth of a structure and dividing the result by the total square footage of the lot. If a CCR standard of 7.50 was applied to a 10,000 square foot lot, a 15 foot tall (1-story) house could be about 70 feet wide and 71 feet deep. Both floors of a 30 foot tall (two-story) house could be approximately 50 feet wide and 50 feet deep. CCR standards do not directly alter the dimensions of the three-dimensional envelope in which buildings may be built. A CCR standard, however, will generally make it difficult or impossible to build a structure that fills the entire envelope. Accessory structures and porches are sometimes excluded from CCR calculations.

Advantages of CCR Standards:

- Directly relates the scale of structures to the size of the lot
- May encourage lower floor-to-floor heights
- Can be combined with lot coverage and height limits to break down the overall scale of structures
- Can be used to provide an incentive for front porches or detached garages and accessory structures

Potential Disadvantages of CCR Standards:

- Could encourage overly box-like structures when not combined with other standards and guidelines
- Could discourage wall sculpting and articulation
- Could permit overly large structures on large lots
- Could constrain the building potential of small lots
- Very difficult to calculate and understand

Existing Regulations: CCR standards are not currently used.

Cubic Content Ratio Standards

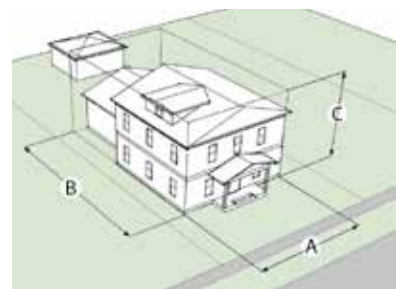

The primary structure illustrated above is on a 7,500 square foot lot and is 35 feet wide (A), 50 feet deep (B) and 23 feet high (C). The resulting CCR is 5.37. A box shaped structure filling the entire area would have the same CCR.

Potential Application Strategies

Each potential tool discussed in the previous sections could be applied in different ways. Several approaches are discussed below, including:

- Apply Tools Uniformly Throughout the Neighborhoods
- Vary Their Application by Neighborhood or by a Smaller Character Area
- Vary Their Application by Lot Size
- Vary Their Application by Zoning District
- Apply Tools Only in Certain Zoning Districts, Neighborhoods or Character Areas
- Combined Application

Option: Apply Tools Uniformly Throughout the Neighborhoods

Those tools selected to be used could be applied in a uniform manner across the neighborhoods. That is, their application would not vary based on zoning district, lot size or other criteria. For example, a new maximum building coverage limit of 30% could be applied to all properties in the project area.

Advantage of Uniform Application:

- Simple to administer and enforce

Potential Disadvantage of Citywide Application:

- “One Size Fits All” – may have unintended consequences due to its broad application in all situations

Option: Vary Application by Neighborhood or Area

The selected tools could be applied differently depending on specific neighborhoods or areas (such as the character areas described on page 28). For example, a certain building coverage standard could be applied in the Eastside and a different building coverage standard could be applied in the Westside, both of which are currently within the two project zoning districts.

Advantages of Varying Application by Neighborhood or Area:

- Avoids the “one size fits all” issues of a uniform approach
- Allows specific numeric standards to be developed for each neighborhood or area
- Sensitive to context

Disadvantages of Varying Application by Neighborhood or Area:

- May be difficult to determine where these areas should be mapped
- Multiple standards in different areas may be harder to enforce
- May depend on time-consuming neighborhood planning efforts

Option: Vary Application by Lot Size

One possible approach to matching homes to their underlying lot size is to establish standards that vary by the lot size itself. When the standards were applied to smaller lots, the result would be a smaller house.

Advantages:

- Avoids the “one size fits all” issues of a citywide approach.
- Allows specific numeric standards to be developed for each lot size. Matches house size to underlying lot.

Disadvantages:

- Multiple standards in a given zoning district may be harder to administer and enforce.

Option: Vary Application by Zoning District

Much like varying the standards by neighborhood or area, varying them by zoning district is possible. This approach assumes that areas zoned similarly have similar problems and should be treated in similar fashion.

Advantages:

- Avoids the “one size fits all” issues of a citywide approach
- Allows specific numeric standards to be developed for each district

Disadvantages:

- Zoning districts may not be similar in character.
- Multiple standards in different areas may be harder to enforce.

Option: Apply Selected Tools Using Thresholds

Another option is to “trigger” the use of a tool when a certain threshold is exceeded. For example, the existing FAR standard could be used as a filter for applying an additional requirement to articulate building form. In such a system, any new development that would result in a project exceeding an FAR of .35, for instance, would then be required to provide articulation, perhaps from a menu of choices, to break up the perceived mass of the building. Any project below that threshold would not be required to do so. Such a threshold system could also be used for public notice, or other process requirements.

Option: Apply Tools Only in Certain Zoning Districts, Neighborhoods or Areas

The recommended tools could be applied only to certain zoning districts, neighborhoods or areas. For example, they could be applied only in the N-C-L zoning district with no changes made in any other district.

Option: Combined Application

The final option worth considering is using a combination of the approaches. Some tools may be implemented on a neighborhood-wide basis, while others relate to a specific area, and still others to small or large lots. This fine-grained combination would likely yield the best result.

Part 4

Strategy Options

City Council's overall goal for the study is to retain and enhance the unique character and context of the Eastside and Westside Neighborhoods as they continue to change with renovations, additions and new housing construction.

Based on community comments to date, five strategy options have been identified to promote Council's goal. A sixth option, "Take no Action" acknowledges feedback from some participants that there is not an issue, or that new tools and strategies should not be considered. Strategy options 1–5 include the tools described in Part 3 that would best address the identified neighborhood objectives and issues while meeting criteria for fairness, predictability and effectiveness.

An early version of the strategy options was presented in a working paper dated October 2, 2012. Based on feedback from the October working group, they were then revised for inclusion in the *Preliminary Strategy Report* dated November 1, 2012. The strategy options included in this draft of the report have been further updated and refined based on feedback received at the November workshop and on the online visual survey. See "Selection Criteria" on page 112 for more information.

This part of the report begins with a description of selection criteria and application considerations for the strategy options, followed by a summary of the options, details on each option and its associated tools, and information about next steps.

City Council may provide direction to move forward with all of the suggested strategy options, or may select a smaller number of options for early implementation or additional evaluation and development.



Part 4 Contents

Selection Criteria.....	112
Scope and Application.....	113
Overview of Strategy Options	114
Strategy Options Detail	116
1. Promote Design Assistance.....	117
2. Expand Notification.....	118
3. Create Design Handbooks/Guidelines.....	119
4. Adjust Measurement	120
5. Address Building Massing / Solar Access	124
6. Take No Action	131
Annual Review.....	131
Other Strategies and Tools (not selected)....	131
Potential Future Strategies.....	132
Address N-C-B Zoning.....	132
Address Other Zoning Boundaries.....	132
Consider Citywide Application.....	132

Selection Criteria

Objectives and Issues

As described in Part 2: "Community Comments" on page 55, the study's public process identified a range of neighborhood objectives and issues.

Objectives include:

1. Promote awareness of what makes the neighborhoods great
2. Promote compatible redevelopment
3. Maintain a sense of community
4. Encourage communication among neighbors
5. Preserve flexibility for change and reinvestment
6. Acknowledge economic impacts

Issues include:

- A. New construction that appears to be overly large in relation to its context
- B. Building walls that appear to loom over neighbors
- C. Reduced solar access/shading issues
- D. Incompatible design features
- E. Loss of older/more affordable houses
- F. Loss of green space and mature trees

The strategy options are intended to address the neighborhood objectives and issues identified in the study's public process, as well as an initial evaluation of potential tools and preliminary strategy options in working group sessions and in the November workshop. These strategy options also include the following evaluation criteria:

1. Effectiveness

The tool should directly address one or more specific objectives or issues identified within the neighborhoods. For example, adjusting the way that building height is measured at the side yard setback to account for grade changes directly addresses the issue of new construction and additions that appear to be overly large and tall in relation to their neighbors.

2. Fairness

The tool should apply equally to all similar properties and should not create undue hardships on unique properties. For example, the maximum wall height at the side yard setback should be the same for all similarly sized lots located within the same zone district, and should allow for sufficient flexibility under unique conditions such as especially narrow or steeply sloping lots.

3. Predictability

The tool should be understandable by property owners, neighbors, architects and builders. It should also produce predictable results by clearly defining what is permitted and what is not. For example, an FAR standard should support a reasonable understanding of the total volume/mass and scale of construction that could occur on a particular lot.

4. Efficiency

The tool should be part of an easily administered process that is cost effective and sets clearly defined expectations for property owners, builders and architects. For example, a height measurement system that does not require extensive site surveys would be preferred.

Scope and Application

Although most participants in the public outreach process felt that there is an issue with demolitions, new construction and additions in the neighborhoods, they also indicated that they felt the issues were limited to certain areas or situations within the neighborhoods, or to a small number of construction projects. Therefore, some of the tools included in the strategy options, such as expanded notification, or standards to address perceived scale, would only apply to the largest new construction or additions based on thresholds to be determined. See page 74 for more information on community comments.

Other tools, such as voluntary design guidelines or adjusted measurement methods would apply to all new construction and additions in the N-C-L and N-C-M zone districts. If selected for further evaluation, any revisions to FAR standards could vary by zone district.

"Potential Application Strategies" on page 108 of the *Potential Tools* section describes other possible application considerations, such as varying application by neighborhood, character area or lot size. These application strategies may be considered based on additional community comment or City Council direction. However, they are not currently suggested because:

- Some participants from both neighborhoods indicated issues or concerns with demolition and new construction.
- It is not clear that issues or concerns occur most often on particular sizes or types of lots.
- Although issues or concerns may be more pronounced in some neighborhood areas, participants in other areas also have concerns. (See "Character Areas" on page 28 for more information)

Options Suggested for Early Implementation

Management staff requested identification of options that could be adopted and implemented relatively quickly to address identified objectives and issues while additional options are evaluated.

Promoting the City's existing design assistance program and expanding variance notification are suggested as potential early implementation options. They are indicated with diamond symbols in the following pages.

Options Suggested for Further Evaluation

Management staff also requested identification of additional options for further evaluation to address identified issues and objectives.

Creating design handbooks, adjusting measurement methods and addressing building massing are suggested for further evaluation. They are indicated with check marks in the following pages.



Overview of Strategy Options

The key strategy options are briefly summarized below, and in the table on the next page. The tools included within each option are also described in greater detail in "Tools Used in the Strategy Options" starting on page 116. City Council will provide direction on which options to pursue at a work session on November 27, 2012.

- ◆ **1. Promote Design Assistance.** This would promote access to, and use of the City's current design assistance program. Additional detail is provided on page 117.

- ◆ **2. Expand Notification.** This would extend notification of requested variances exceeding a certain project size or other thresholds as determined for comment on pending changes in the neighborhoods. Additional detail is provided on page 118.

- ✓ **3. Create Design Handbooks/Guidelines.** This would include development of voluntary design handbooks or guidelines to promote compatible development in unique character areas throughout the neighborhoods. Additional detail is provided on page 119.

- ✓ **4. Adjust Measurement.** This would adjust the method for measuring building height at the minimum side yard setback and FAR to better account for the impact of tall walls on raised grade and high volume spaces. Additional detail is provided on page 121.

- 5. Address Building Massing and Solar Access.** This would apply new or adjusted design standards (zoning requirements) to address the scale and solar access impacts of larger new construction and additions. One of the following options would be considered per direction from City Council:
 - ✗ **5a. Address Scale Directly** (not suggested). This would use revisions to existing maximum FAR standards to directly address building scale. Additional detail is provided on page 122.









 - ✗ **5b. Address Solar Access Directly** (not suggested). This would introduce a standard limiting the amount of shadow that new construction/additions could cast on a neighboring property based on an equivalent "solar fence." Note that this is not a suggested strategy option. Additional detail is provided on page 125.

 - ✓ **5c. Address Massing and Solar Impacts with Design Tools.** This would provide a menu of options for shaping the mass of new construction/additions exceeding a specific FAR threshold to address both massing and solar access. Additional detail is provided on page 125.

- 6. Take No Action.** This would not introduce new regulatory tools or strategies. Additional detail is provided on page 131.

- Legend**
- ◆ = Strategy option suggested for early implementation.
 - ✓ = Strategy option suggested for further evaluation and development.
 - ✎ = Strategy option that would apply only to targeted properties/projects (would not apply to most new construction/additions)
 - ✗ = Strategy option that is not suggested at this time, but may be considered by City Council as an alternative.

Summary of Strategy Options

Design Standards		Process and Education Tools				
Strategy Options	Relationship to Character/Context	Objectives Addressed	Issues Addressed	Potential Advantages	Potential Disadvantages	
<p> 1. Promote Design Assistance Market existing design assistance program</p> <p> 2. Expand Notification Notification of Variances</p>	<ul style="list-style-type: none"> Promotes context-sensitive design May have greater impact on small or unusual lots 	<ol style="list-style-type: none"> Awareness Compatibility Community Communication 	<ul style="list-style-type: none"> D. Design Features B. Looming C. Solar Access 	<ul style="list-style-type: none"> High level of agreement Relatively fast implementation 	<ul style="list-style-type: none"> Does not directly address key mass and scale concerns Requires administration by the City 	
<p> 3. Create Design Handbooks/ Guidelines Voluntary Design Handbooks or Guidelines</p>	<ul style="list-style-type: none"> Promotes context-sensitive design 	<ol style="list-style-type: none"> Awareness Compatibility Flexibility 	<ul style="list-style-type: none"> D. Design Features 	<ul style="list-style-type: none"> High level of agreement Context sensitivity 	<ul style="list-style-type: none"> Time/\$ to develop Voluntary guidelines may not address key mass and scale concerns 	
<p> 4. Adjust Measurement Height Measurement at the Side Yard FAR Measurement</p>	<ul style="list-style-type: none"> Primarily impacts existing low-scale character areas Primarily impacts character areas with larger construction on small lots 	<ol style="list-style-type: none"> Compatibility Compatibility 	<ul style="list-style-type: none"> A. Mass and Scale C. Solar Access F. Green Space 	<ul style="list-style-type: none"> Directly addresses key issues Relative ease of implementation 	<ul style="list-style-type: none"> Diversity of opinions (there is a relatively high level of support – especially for height) 	
<p> 5. Address Building Massing/Solar Access Select one alternative:  5a. Address Scale Directly Maximum FAR</p>	<ul style="list-style-type: none"> Primarily impacts character areas with larger construction on small lots 	<ol style="list-style-type: none"> Compatibility 	<ul style="list-style-type: none"> A. Mass and Scale C. Solar Access F. Green Space 	<ul style="list-style-type: none"> Directly addresses key mass and scale issues 	<ul style="list-style-type: none"> Diversity of opinions 	
<p> 5b. Address Solar Access Directly Solar Access Standards</p>	<ul style="list-style-type: none"> Primarily impacts character areas with taller new construction Greater impact on east-west oriented lots 	<ol style="list-style-type: none"> Economic Impacts 	<ul style="list-style-type: none"> C. Solar Access 	<ul style="list-style-type: none"> Directly addresses key issue Does not limit house size 	<ul style="list-style-type: none"> Diversity of opinions Complex implementation 	
<p> 5c. Address Massing and Solar Impacts with Design Tools Front Façade Massing Side Façade Massing and Solar Access</p>	<ul style="list-style-type: none"> Primarily impacts character areas with larger construction Primarily impacts character areas with larger construction 	<ol style="list-style-type: none"> Compatibility Community Compatibility Flexibility 	<ul style="list-style-type: none"> A. Mass and Scale A. Mass and Scale B. Looming C. Solar Access 	<ul style="list-style-type: none"> Does not limit house size 	<ul style="list-style-type: none"> Diversity of opinions May not address issues as directly as FAR 	
<p>6. Take No Action</p>		<ol style="list-style-type: none"> Flexibility 			<ul style="list-style-type: none"> Diversity of opinions Does not address issues 	



The strategy options presented in this report were refined based on community comments received during the November neighborhood workshop.

Strategy Options Detail

With the exception of option 6, each strategy option described in the following pages would implement one or more education, process or design tools to address the neighborhood objectives and issues summarized on page 112.

As described on page 113, strategy options 1 and 2 include voluntary or process tools that are suggested for early implementation. Option 3 includes a voluntary tool that is suggested for later evaluation and development, and options 4 and 5 include regulatory tools that are suggested for further evaluation and development. Option 6 is not suggested.

Each strategy option would be implemented with one or more tools. For example, strategy option 4 would use height measurement at the side yard and floor area ratio measurement tools. Strategy option 5 presents a choice of three alternative sets of tools that could be implemented to address building massing and solar access. One alternative is suggested, but City Council may provide direction to pursue other alternatives.

1. Promote Design Assistance

This strategy option would promote access to, and use of the City’s current program that provides free or reduced cost architectural services to applicants seeking assistance with compatible design. Details on the specific tool are provided below.



Education Tool: Market the Design Assistance Program

<p>Current Program</p>	<p>In late 2011, the City started a design assistance program that aims to enhance neighborhood compatibility through the assistance of experienced professionals with success in context-sensitive historic design. Participants in the public process for this study noted that many residents are not aware of the existing design assistance program.</p>		
<p>Character / Context</p>	<p>A design assistance program can take into account information about the character of the neighborhoods to promote context-sensitive design. For example, design professionals that are part of the program would be familiar with any design guidelines, character areas or other information available about designing new construction or additions to be compatible with existing conditions.</p>		
<p>Community Comment</p>	<p>Many residents indicated that a program to provide design assistance could help promote compatible additions and new construction in the neighborhoods.</p> <table border="0"> <tr> <td data-bbox="350 997 878 1136"> <p>Objectives Addressed:</p> <ol style="list-style-type: none"> 1. Promote awareness 2. Promote compatible redevelopment </td> <td data-bbox="878 997 1401 1136"> <p>Issues Addressed:</p> <ol style="list-style-type: none"> D. Incompatible design features </td> </tr> </table>	<p>Objectives Addressed:</p> <ol style="list-style-type: none"> 1. Promote awareness 2. Promote compatible redevelopment 	<p>Issues Addressed:</p> <ol style="list-style-type: none"> D. Incompatible design features
<p>Objectives Addressed:</p> <ol style="list-style-type: none"> 1. Promote awareness 2. Promote compatible redevelopment 	<p>Issues Addressed:</p> <ol style="list-style-type: none"> D. Incompatible design features 		
<p>Pro / Con</p>	<p>Design assistance programs received a high level of support in the public process and could be implemented relatively quickly. There were no disadvantages recognized with promotion of the programs.</p>		
<p>Scope</p>	<p>Expanded marketing of the design assistance program would apply to all qualifying properties Citywide.</p>		
	<p>This tool is suggested for early implementation as part of Strategy Option 1. It may be combined with later development and implementation of additional strategy options.</p>		

2. Expand Notification

This strategy option would extend notification of requested variances exceeding a certain project size or other thresholds, to be determined, to allow for comment on pending changes in the neighborhoods. Details on the specific tool are provided below.

Administrative Tool: Notification of Variances

<p>Current Program</p>	<p>The City currently requires mailed notice to property owners within 150' of a property where a zoning variance is requested. There is no requirement to post a sign. Notification is addressed in land use code section 2.10.2(F).</p>						
<p>Character / Context</p>	<p>Variances may be requested on any property citywide, and are reviewed using a process that determines if the particular conditions of the property present a hardship that requires a variance, or satisfies the "nominal, inconsequential" or the "equal to or better than" standard. In practice, the conditions for granting a variance may occur more often on small or unusual lots. This may be why variance requests in the Eastside and Westside neighborhoods account for almost 38% of variances citywide while the neighborhoods only account for 7% of all building permits citywide.</p>						
<p>Community Comment</p>	<p>Many residents indicated that the current notification program for variances was not sufficient, and that mailed notice should be provided to more property owners, and/or a sign should be posted.</p> <table border="0" data-bbox="331 1045 1409 1173"> <tr> <td data-bbox="331 1045 857 1077">Objectives Addressed:</td> <td data-bbox="865 1045 1409 1077">Issues Addressed:</td> </tr> <tr> <td data-bbox="331 1087 857 1119">3. Maintain a sense of community</td> <td data-bbox="865 1087 1409 1119">B. Looming building walls</td> </tr> <tr> <td data-bbox="331 1119 857 1150">4. Encourage communication</td> <td data-bbox="865 1119 1409 1150">C. Reduced solar access</td> </tr> </table>	Objectives Addressed:	Issues Addressed:	3. Maintain a sense of community	B. Looming building walls	4. Encourage communication	C. Reduced solar access
Objectives Addressed:	Issues Addressed:						
3. Maintain a sense of community	B. Looming building walls						
4. Encourage communication	C. Reduced solar access						
<p>Pro / Con</p>	<p>Most participants in the public process supported the concept of expanding notification of variance requests (which occur significantly more often in the Eastside and Westside than in other neighborhoods). While such a tool could promote communication about changes in the neighborhood and be implemented relatively quickly, it would not directly address resident concerns about the mass and scale of some new construction and additions in the neighborhoods.</p>						
<p>Scope </p>	<p>Extended notification would apply only to new construction and additions that exceed a certain project size or other thresholds, to be determined.</p>						
<p></p>	<p>This tool is suggested for early implementation as part of Strategy Option 2. It may be combined with later development and implementation of additional strategy options.</p> <p>Suggested extension of notification is to 500' or 800', with a posted sign on the subject property.</p> <p>Many residents also indicated that notice should be provided for larger new construction and additions in the neighborhoods. However, because such a program would apply to new construction that meets existing zoning standards, it could imply that neighborhood agreement is necessary before such a project could proceed. However, City Council may determine that notification of new construction should be evaluated further.</p>						

3. Create Design Handbooks/Guidelines

This strategy option would provide direction to pursue development of design handbooks, or guidelines to assist property owners, designers and builders with compatible, context-sensitive design. Details on the specific tool are provided below.



Education Tool: Voluntary Design Handbook or Guidelines

Existing	<p>In 1996 a voluntary Design Guidelines document was developed for the Eastside and Westside neighborhoods. However, this document is considered outdated and as a result, is used infrequently.</p>		
Character / Context	<p>Design handbooks can work closely with information about the existing character and context of the neighborhoods, such as that summarized in Part 1: "Neighborhood Profile" on page 7. They may also provide customized guidance for different character areas in the neighborhoods, such as those summarized on page 28.</p>		
Community Comment	<p>Many residents expressed a strong interest in providing design handbooks or guidelines to educate property owners, architects and builders about compatible, context-sensitive design in the neighborhoods. Interest was primarily in applying design guidelines as voluntary or linked to incentives rather than as requirements.</p> <table border="0" data-bbox="358 999 1435 1136"> <tr> <td data-bbox="358 999 878 1136"> <p>Objectives Addressed:</p> <ol style="list-style-type: none"> 1. Promote awareness 2. Promote compatible redevelopment 5. Preserve flexibility </td> <td data-bbox="878 999 1435 1136"> <p>Issues Addressed:</p> <ol style="list-style-type: none"> D. Incompatible design features </td> </tr> </table>	<p>Objectives Addressed:</p> <ol style="list-style-type: none"> 1. Promote awareness 2. Promote compatible redevelopment 5. Preserve flexibility 	<p>Issues Addressed:</p> <ol style="list-style-type: none"> D. Incompatible design features
<p>Objectives Addressed:</p> <ol style="list-style-type: none"> 1. Promote awareness 2. Promote compatible redevelopment 5. Preserve flexibility 	<p>Issues Addressed:</p> <ol style="list-style-type: none"> D. Incompatible design features 		
Pro / Con	<p>Most participants in the public process supported development of design handbooks or guidelines. While such tools provide context-sensitive guidance and are highly flexible, their voluntary nature may not directly address resident concerns about the mass and scale of some new construction and additions in the neighborhoods.</p>		
Scope	<p>Design handbooks or guidelines would provide guidance for all properties in the Eastside and Westside Neighborhoods (N-C-L and N-C-M zoning districts).</p>		
	<p>This tool is suggested for further evaluation and later development as part of Strategy Option 3. It may be combined with development and implementation of additional strategy options.</p> <p>Design handbooks or guidelines should illustrate compatible projects that comply with all standards and regulations to assist with an understanding of what can be built in the neighborhoods. Although they are suggested to be voluntary, design guidelines and handbooks could be linked to incentives such as the design assistance program.</p> <p>This tool would require additional staff or consultant resources to implement. If selected, future work programs may need to be adjusted to accommodate design handbook or guidelines development.</p>		

4. Adjust Measurement

This strategy option would provide for further evaluation and development of adjustments to the measurement method for building height at the minimum side yard setback and floor area ratio (FAR). Adjustments are intended to better account for the impact of tall walls on raised and high volume spaces. Details on each tool are provided below.

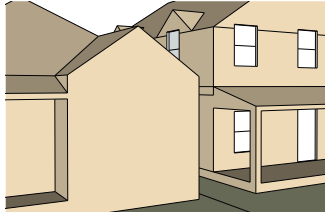
Design Tool: Height Measurement at the Side Yard

<p>Current Standard</p>	<p>The City currently limits building height to 18' at the 5' minimum side yard setback in the N-C-L and N-C-M zoning districts, with 2' of additional height allowed for each 1' of increased setback. Height is measured from actual grade at the base of the structure, allowing for a taller height in relation to neighbors when grade has been raised as illustrated at bottom right. Height in relation to side setback is addressed in land use code sections 4.7(E)(4) and 4.8(E)(4).</p>	
<p>Character / Context</p>	<p>Adjusting measurement of building height at the minimum side yard setback is likely to have the greatest impact in Character Areas 3, 5 and 6, where most existing buildings are one story and there is a higher potential for taller new construction or additions to loom over neighbors.</p>	
<p>Community Comment</p>	<p>Many residents indicated that the height of new construction in relation to neighbors was a key issue. They also noted that the current height measurement method may allow for structures that loom over their neighbors when they are built on a natural slope, or a site where the grade has been raised (73% of visual survey participants felt that "Measuring wall height from original grade can help promote neighborhood compatibility").</p> <p>Objectives Addressed:</p> <ul style="list-style-type: none"> 2. Promote compatible redevelopment <p>Issues Addressed:</p> <ul style="list-style-type: none"> A. Overly large new construction B. Looming building walls C. Reduced solar access 	
<p>Pro / Con</p>	<p>Most participants in the public process felt that this tool would directly address key mass and scale and looming issues related to new construction and additions built on raised grade or sloping sites. In addition, this tool could indirectly address issues with solar access. However, some participants felt that adjusting the measurement method would be overly restrictive on some sites, especially when grade must be raised to address flood standards.</p>	
<p>Scope</p>	<p>Adjusted measurement of height at the side yard would apply to all properties in the Eastside and Westside Neighborhoods (N-C-L and N-C-M zoning districts). This tool is not relevant to other neighborhoods in the city where building height at the side yard is not regulated.</p>	
<p></p>	<p>This tool is suggested for further evaluation and development as part of Strategy Option 4 (which also includes adjusting FAR measurement). It may be combined with development and implementation of additional strategy options.</p> <p>Height would be measured from the natural grade at the interior side lot line directly as illustrated on the next page. Limited exceptions may be considered for dormers and side-facing gables, as well as for situations where buildings or grade must be raised to promote safe and satisfactory drainage or comply with flood standards.</p>	

Design Tool: Height Measurement at the Side Yard (comparison of measurement methods)

As illustrated below, the existing 18' height limit at the side yard setback means that a portion of any second story built directly at the side setback must be built partly within the roof form. Adjusting the measurement method for building height at the side yard setback would lower the height of the second floor (more would be built within the roof form) where grade has been raised. Note that an increased side setback is necessary to build a full second story under either the existing or suggested measurement methods.

Overview of Current Measurement Method

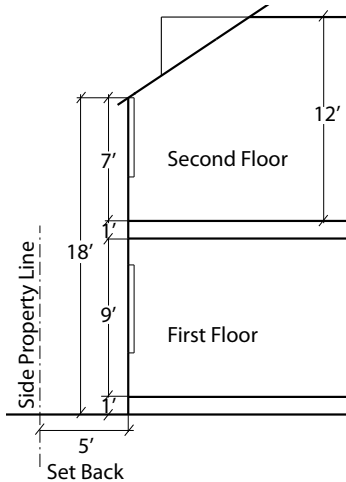

Currently, building height at the side setback is measured from the base of the wall.

Overview of Adjusted Method

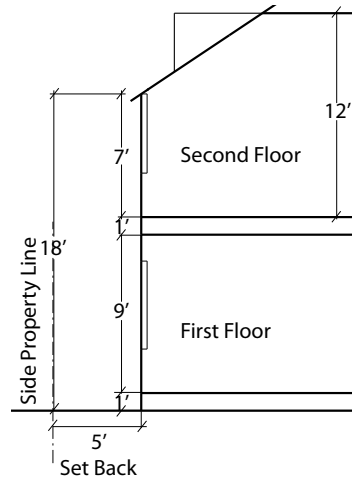

The adjusted method would measure height from natural grade at the side property line. This method would have no impact on a flat site that has not been re-graded.

Current Method on Raised Grade

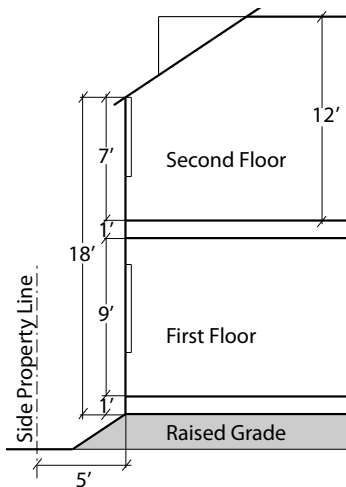

Where grade has been raised, or a property slopes upward from the property line, the current method measures height from the raised level at the base of the wall.

Adjusted Method on Raised Grade

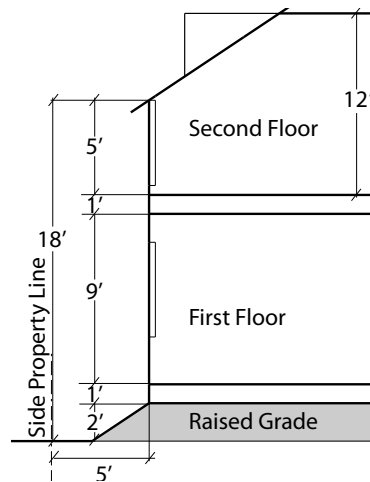

Because the adjusted method would measure building height from the natural grade at the side property line, the height of a second story would be lower where grade has been raised.

Design Tool: Floor Area Ratio (FAR) Measurement

Current Standard The City currently limits maximum FAR (or "lot ratio") in the N-C-L and N-C-M zoning districts. FAR measurement includes the floor area of the primary structure as well as the floor area of any accessory structures that are larger than 120 square feet. However, the current measurement method for FAR does not differentiate between interior building areas of different heights (a double height room with a cathedral ceiling is counted the same as a room with a typical ceiling height). FAR is addressed in land use code sections 4.7(D)(1), 4.7(D)(5), 4.8(D)(1) and 4.8(D)(5).

Character / Context Adjusting FAR measurement is likely to have the greatest impact in character areas where new construction and additions tend to have the highest FARs.

Community Comment Many residents have indicated that the current measurement method for Floor Area Ratio (FAR) may not adequately account for the total volume or perceived mass and scale of different building or floor area configurations.

Objectives Addressed:	Issues Addressed:
2. Promote compatible redevelopment	A. Overly large new construction C. Reduced solar access F. Loss of green space

Pro / Con Many participants in the public process felt that this tool would help "close a loop-hole" that allows for the construction of large volume spaces that are counted the same as rooms with a typical ceiling height. In addition, this tool could indirectly address issues with solar access. However, some participants felt that adjusting the FAR measurement method would be overly restrictive.

Scope Adjusted FAR measurement would apply to all properties in the Eastside and Westside Neighborhoods (N-C-L and N-C-M zoning districts). This tool is not relevant to other neighborhoods in the city where FAR is not regulated.

 **This tool is suggested for further evaluation and development as part of Strategy Option 4** (which also includes adjusting height measurement). It may be combined with development and implementation of additional strategy options including potential revisions to base FAR standards.

The measurement method would be adjusted to:

- Establish a "virtual floor area" for large volume spaces with floor-to-ceiling heights above 11', as illustrated on the next page.
- More clearly define basement floor area to ensure that only floor areas with external visual impacts are counted towards maximum FAR as illustrated on the next page.
- Exempt a portion of the floor area of a detached accessory building located at least 10' behind the principal building to promote separate building masses.

Design Tool: FAR Measurement (virtual floor area and basement calculation)

The FAR measurement method would be adjusted to better account for external visual impacts by recognizing the impact of high volume spaces and explicitly exempting basement square footage that has little or no external visual impact. Potential measurement methods are illustrated below. The measurement method used in Ordinance 003, 2011 (not currently adopted) could also be considered.

Virtual Floor Area Calculation to Account for High Volume Spaces

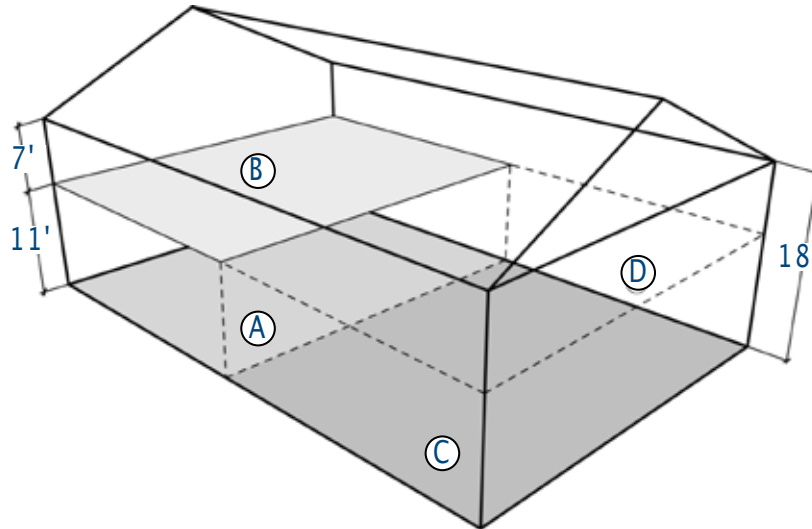

A virtual floor area calculation would be established to better account for the visual impacts of large volume spaces. Any interior area with a floor-to-floor height greater than 11' (as measured at the exterior walls) could be counted as having an additional "virtual floor." In the example illustrated above, floor areas (A) and (B) have floor-to-floor heights of 11' or less. Floor area C is a high volume space with a floor-to-floor height of 18', which creates a virtual second floor area (D) that would also count towards maximum FAR.

Basement Floor Area Calculation

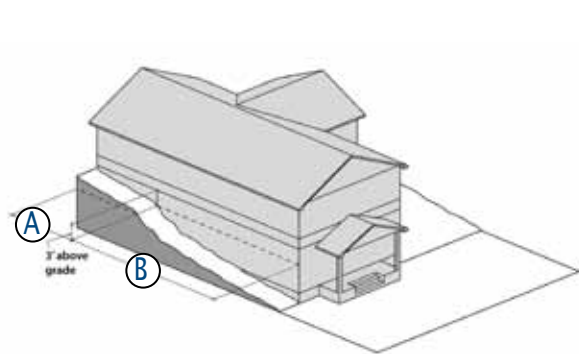
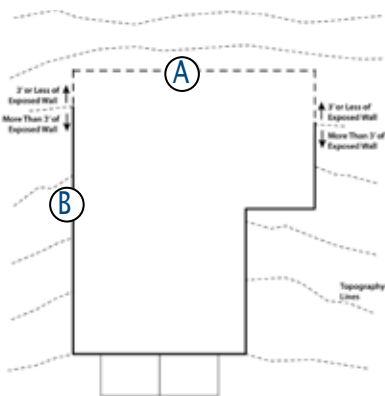

The floor area of basements with exterior walls that are not exposed above ground by more than 3' would not be counted towards maximum FAR while more exposed basement areas would be partially counted. In the example illustrated above, exterior wall area (A) is exposed by 3' or less while exterior wall area B is exposed by more than 3'. The percent of basement floor area counted towards maximum FAR could be calculated as $(\text{Length of wall B}) / (\text{Length of wall A} + \text{B})$.

5. Address Building Massing / Solar Access

This strategy option would provide for further evaluation and development of new or revised design standards (zoning requirements) to address the scale and solar access impacts of larger new construction and additions. As described below, City Council may select one of three alternative sets of tools to implement this strategy option (alternative "c" is suggested).

5a. Address Scale Directly

This would use revisions to maximum FAR standards to directly address building scale. Solar access would be addressed indirectly through reductions in building mass. Details on the specific tool are provided below.

Design Tool: Maximum Floor Area Ratio (FAR)

Current Standard	The City currently specifies a minimum lot area in relation to the total floor area of buildings on the lot in the N-C-L and N-C-M zoning districts. This standard creates a de facto maximum FAR of 0.40 in the N-C-L district and 0.50 in the N-C-M district as described in "Existing Regulations Summary" on page 46. FAR is addressed in land use code sections 4.7(D)(1), 4.7(D)(5), 4.8(D)(1) and 4.8(D)(5).		
Character / Context	Adjusting base FAR standards is likely to have the greatest impact in character areas where new construction and additions tend to have the highest FARs.		
Community Comment	<p>Many residents expressed concern with some new construction that is seen as inappropriately large in relation to its neighbors or the traditional scale of the neighborhood, noting that adjustments to the City's current maximum FAR standards could help address mass and scale issues in the neighborhoods.</p> <table border="0"> <tr> <td data-bbox="331 1255 852 1386"> <p>Objectives Addressed:</p> <p>2. Promote compatible redevelopment</p> </td> <td data-bbox="860 1255 1412 1386"> <p>Issues Addressed:</p> <p>A. Overly large new construction C. Reduced solar access F. Loss of green space</p> </td> </tr> </table>	<p>Objectives Addressed:</p> <p>2. Promote compatible redevelopment</p>	<p>Issues Addressed:</p> <p>A. Overly large new construction C. Reduced solar access F. Loss of green space</p>
<p>Objectives Addressed:</p> <p>2. Promote compatible redevelopment</p>	<p>Issues Addressed:</p> <p>A. Overly large new construction C. Reduced solar access F. Loss of green space</p>		
Pro / Con	Many participants in the public process felt that FAR adjustments could most directly address issues with the mass and scale of some new construction. In addition, this tool could indirectly address issues with solar access. However, some participants felt that FAR adjustments would be overly restrictive.		
Scope	If selected for revision, maximum FAR would differ by N-C-L and N-C-M zone districts and could also use a sliding scale to differ by lot size as described on the next page.		
Not Suggested	This tool is not suggested for further development. However, it provides a potential alternative tool for addressing building massing as part of Strategy Option 5. Although it directly addresses key issues, many residents and other stakeholders feel that it is an overly restrictive tool that limits flexibility for expansion.		

5b. Address Solar Access Directly

This would implement a solar access standard to regulate the amount of shadow that new construction or additions may cause on neighboring properties. Building massing would be addressed indirectly through changes in building form necessary to meet the solar access standard. Details on the specific tool are provided below.

Design Tool: Solar Access Standards

Current Standard	<p>The City does not currently apply solar access standards in the N-C-L and N-C-M zoning districts, or in other zoning districts that apply to established neighborhoods. Solar access standards are, however, applied to new residential developments. Such standards prohibit casting shadow onto structures on adjacent properties greater than the shadow which would be cast by a 25' hypothetical wall located along the property lines of the project between the hours of 9:00 am and 3:00 pm, MST, on December 21.</p> <p>Although the City does not have solar access standards for existing neighborhoods, related standards, such as the height limit at the side yard setback, encourage solar access on neighboring properties.</p>				
Character / Context	<p>Addressing solar access is likely to have the greatest impact on narrow lots with an east/west orientation.</p>				
Community Comment	<p>Many residents indicated that maintenance of solar access is an important consideration as the Eastside and Westside neighborhoods continue to change and develop. Some have noted that, unlike other issues with neighborhood compatibility, solar access is also an economic issue.</p> <table border="0" style="width: 100%;"> <tr> <td style="width: 50%;">Objectives Addressed:</td> <td style="width: 50%;">Issues Addressed:</td> </tr> <tr> <td>6. Acknowledge economic impacts</td> <td>C. Reduced solar access</td> </tr> </table>	Objectives Addressed:	Issues Addressed:	6. Acknowledge economic impacts	C. Reduced solar access
Objectives Addressed:	Issues Addressed:				
6. Acknowledge economic impacts	C. Reduced solar access				
Pro / Con	<p>Solar access tools would directly address a key issue without limiting floor area. However, they would not address mass and scale issues directly and may be complex to create and administer. In addition, some have noted that solar access regulation can result in looming impacts on the south side of a lot because the north side must step down to preserve solar access as illustrated on the next page.</p>				
Scope	<p>Any tools to address solar access would likely apply uniformly to both the N-C-L and N-C-M zone districts.</p>				
Not Suggested	<p>This tool is not suggested for further development. However, it provides a potential alternative tool for addressing solar access as part of Strategy Option 5. Although they directly addresses key issues, solar access standards can be complex to administer. Their impact also differs by lot size and orientation, which could create restrictive conditions on some lots. In addition, other suggested tools to address building massing, such as adjusting measurement of height at the side yard and addressing the character of side walls would help address concerns with solar access.</p>				

5c. Address Massing and Solar Impacts

This would provide a menu of options for shaping the mass of new construction and additions exceeding a specific FAR threshold. The menu options would use design tools to address building massing by shaping the character of front and side building façades, and address solar access by applying additional standards to north-facing side building façades. Details on each specific tool are provided below.

Design Tool: Front Façade Massing

Current Standard
 The City does not currently address the character of the front façade in the N-C-L and N-C-M zoning districts. However, the City does require that the primary entrance to a dwelling be located along the front wall of the building and include an architectural entry feature unless an alternative is required for handicap access.

Character / Context
 Addressing the character of side walls is likely to have the greatest impact in character areas where larger or taller new construction and additions are being built on relatively small lots.



Community Comment
 As illustrated at right, community workshop participants selected design features that they felt would promote compatible new construction in the Eastside and Westside neighborhoods. Lower-scale elements at the street, and covered front porches were among the most commonly selected elements.

Objectives Addressed: Issues Addressed:

2. Promote compatible redevelopment	A. Overly large new construction
3. Maintain a sense of community	



Pro / Con
 Tools to address the character of the front façade may promote compatible buildings and help maintain a sense of community without limiting floor area. However, they do not address mass and scale issues as directly as FAR.

Scope
 This tool would apply only to new construction and additions that exceed an FAR of 0.35 on lots wider than 40'. This would impact about 7% of all projects (new construction/remodels/additions) and 29% of new construction projects (new infill homes), based on the project FARs over the last 10 years in the neighborhoods.

While this tool would not address scale as directly as revisions the maximum FAR standard, the threshold would provide an incentive to remain below an FAR of 0.35.

Checkmark
This tool is suggested for further evaluation and development as part of Strategy Option 5c (which also includes a menu of side façade options). It may be combined with development and implementation of additional strategy options.

A menu of options would be provided to encourage compatible, pedestrian-friendly façades. Such options would include wall offsets, front porches and one-story elements as illustrated on the next page.

Design Tool: Front Façade Massing (menu of design options)

A menu of options to address the character of the front façade to promote compatible mass and scale could include the design features illustrated below (incorporating at least one menu option could be required).

Wall Offsets

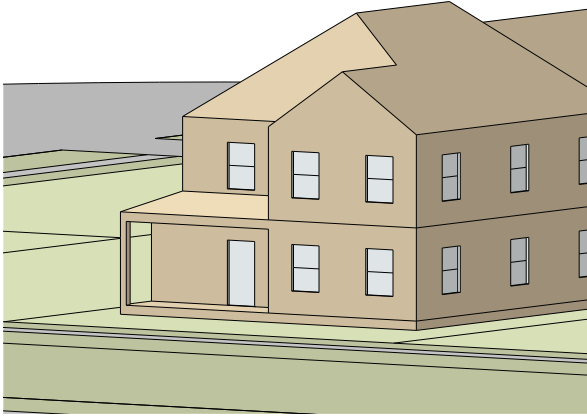

Front Porch

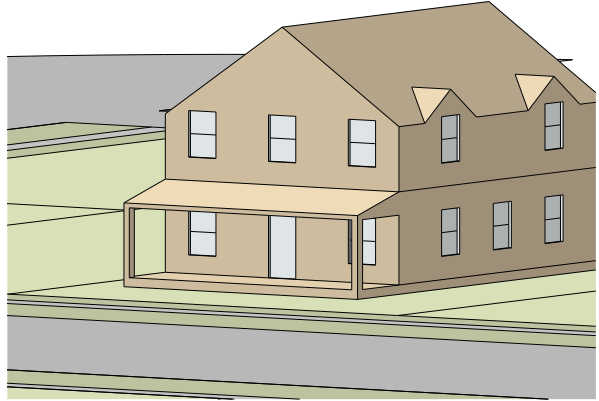

One-Story Element

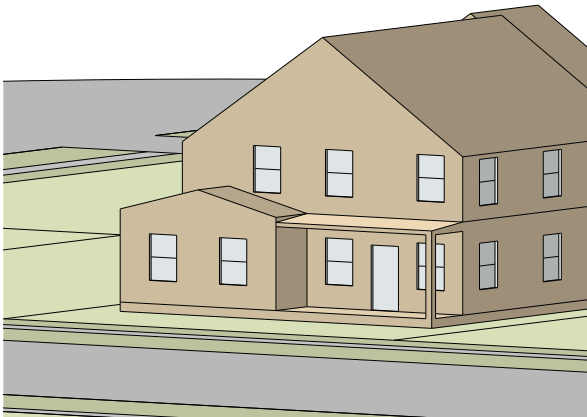

Limited Façade Width

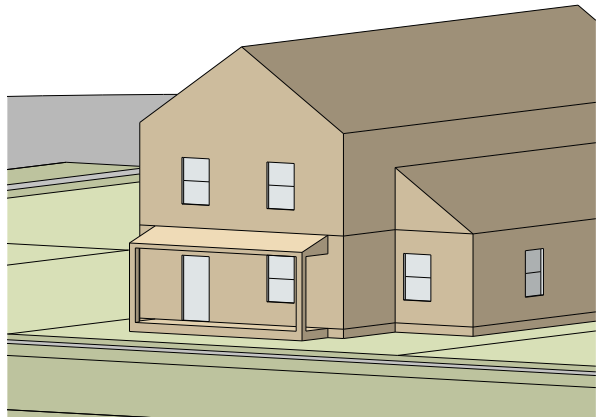

Design Tool: Side Façade Massing and Solar Access

Current Standard As described on page 121, the City currently limits building height at the minimum side yard setback in the N-C-L and N-C-M zoning districts, which partially addresses the massing and potential solar access impacts of side façades. The City does not, however, address the length of taller side façades or provide specific standards for façades that may have solar impacts on neighboring properties.

Character / Context Addressing the massing and potential solar access impacts of side façades is likely to have the greatest impact in character areas where larger or taller new construction and additions are being built. As described on page 130, special standards to promote solar access would primarily impact lots with an east-west orientation (lots facing north-south streets).

Community Comment Community workshop participants reviewed alternative designs for new construction in a variety of contexts throughout the Eastside and Westside neighborhoods and identified which designs they felt were most compatible. The new construction that was most often identified as compatible featured articulated building masses that reduced the appearance of long walls and did not appear to loom over, or block sunlight to, neighboring properties.

Objectives Addressed:

- 2. Promote compatible redevelopment
- 5. Preserve flexibility
- 6. Acknowledge economic impacts

Issues Addressed:

- A. Overly large new construction
- B. Looming building walls
- C. Reduced solar access

Pro / Con Tools to address the massing of side walls and promote solar access may address the perceived mass and scale of a building without limiting its floor area. However, they do not address mass and scale issues as directly as FAR or solar access issues as directly as a solar access standard.

Scope  This tool would apply only to new construction and additions that exceed an FAR of 0.35 on lots wider than 40'. This would impact about 7% of all projects (new construction/remodels/additions) and 29% of new construction projects (new infill homes), based on the project FARs over the last 10 years in the neighborhoods.

This tool is suggested for further evaluation and development as part of Strategy Option 5c (which also includes a menu of front façade options). It may be combined with development and implementation of additional strategy options.



A menu of options would be provided to break down the mass and scale of long, tall side building walls on the side façades of the largest new construction and additions (see "Scope" above). Such options would include wall offsets, varied rooflines and one-story elements as illustrated on the next page. Special height standards would apply to north-facing side façades to address solar access to neighboring properties as illustrated on page 130.

Design Tool: Side Façade Massing and Solar Access (menu of design options for non north-facing façades)

Non north-facing side façades, or north-facing side façades that do not face a neighbor (corner lot), generally do produce significantly reduced solar access for their neighbors. However, such façades may contribute to identified issues with the appearance of overly large new construction and looming building walls.

To implement strategy option 5c, a menu of options would be provided to break down the mass and scale of long, tall building walls on the side façade. An initial assumption is that this standard would apply only to projects/properties meeting all of the following conditions:

- Overall FAR over 0.35
- Two-story side façade greater than 42' in length
- Lot width greater than 40'
- Side façade located within 10' of the minimum side yard setback

Thus, the standards would not apply to narrow lots, buildings with an FAR of 0.35 or less, one-story buildings, or buildings with an increased side setback. A menu of options to address the character of the side façade could include the design features illustrated below (incorporating at least one menu option could be required).

Wall Offset

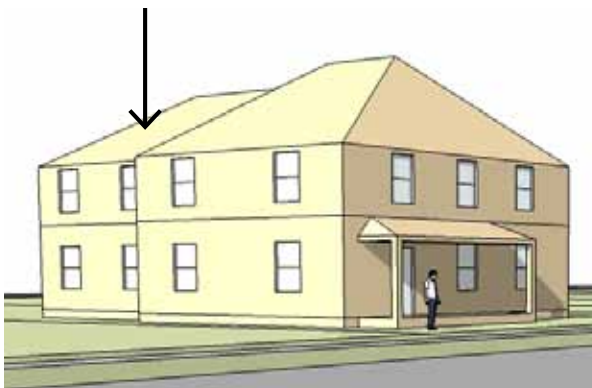

A wall offset to add interest and reduce the perceived mass and scale of a two-story building wall greater than 42' in length.

Step Down in Height



A step down in height to one story. The illustrated example steps down to one-story at the maximum two-story wall length of 42'.

One-Story Element

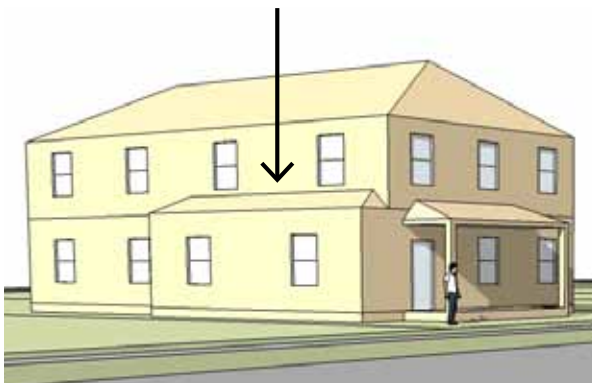

A one-story element to add interest and reduce the perceived mass and scale of a two-story building wall greater than 42' in length.

Wall Notch

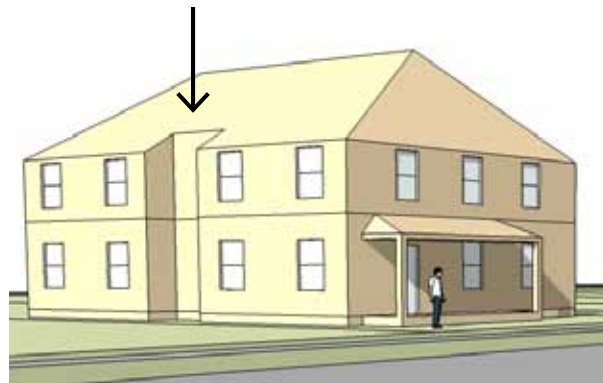

A notch to add interest and reduce the perceived mass and scale of a two-story building wall greater than 42' in length.

Design Tool: Side Façade Massing and Solar Access (standards for façades facing a neighbor to the north)

Tall side façades may produce reduced solar access on a neighboring property to the north.

To implement strategy option 5c, and preserve solar access, maximum height at the side yard setback could be lowered for north-facing side façades, and the angle of potential wall height increase could be reduced to better align with the angle of the winter sun. An initial assumption is that this standard would apply only to projects/properties meeting all of the following conditions:

- Overall FAR over 0.35
- Side façade facing a property to the north
- Lot width greater than 40'
- Side façade located within 10' of the minimum side yard setback

Thus, the standards would not apply to non north-facing side façades, narrow lots, average/modest projects, one-story buildings, or buildings with an increased side setback (note that this narrows the scope of application to about 5% of all projects and 17% of new construction projects). The standard illustrated below would apply in lieu of the menu of options illustrated on page 129.

Lower Wall Height and Reduced Angle to Promote Solar Access

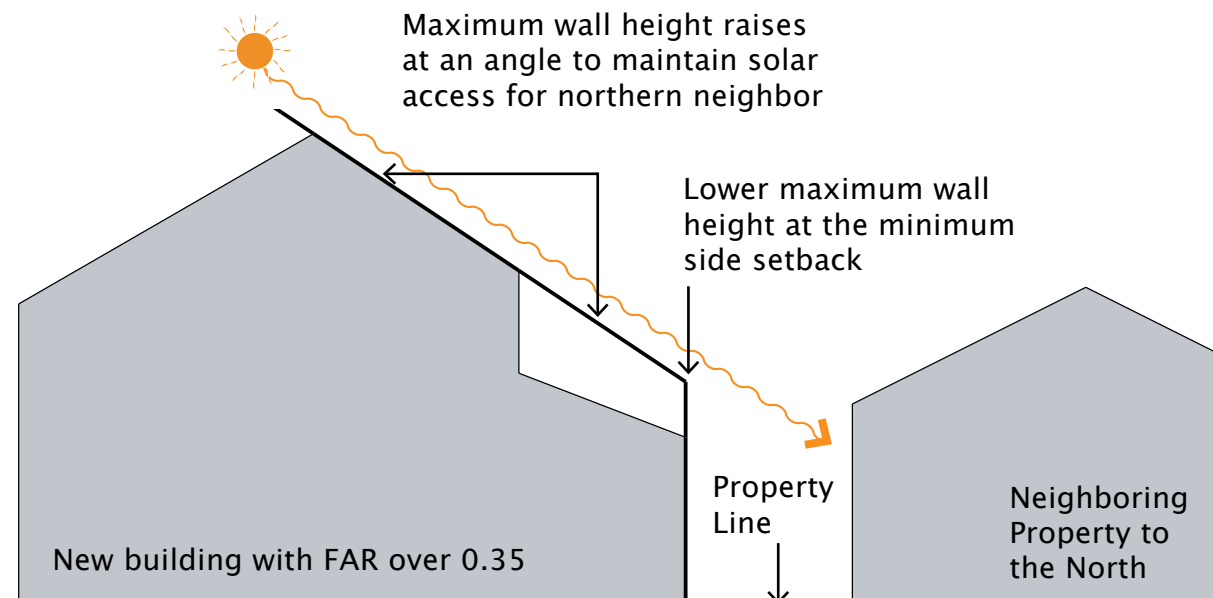

A lower maximum wall height and reduced angle of height increase help maintain solar access on a neighboring property to the north.

Impact on Building Form

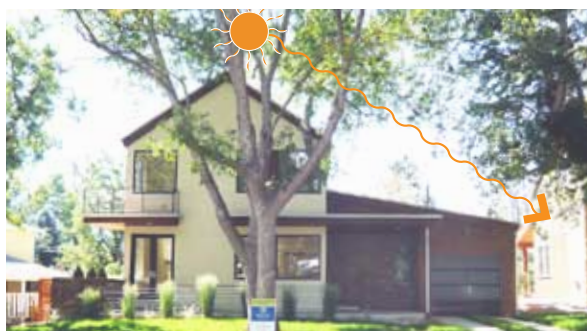

Lowering maximum wall height to protect solar access promotes building forms that step down to the north. Note that the house illustrated at right steps down more than necessary to preserve solar access.

6. Take No Action

This strategy option would not introduce any new tools for early implementation or further evaluation in development. Some residents indicated that they do not feel there is an issue and would like to ensure that City Council continues to consider taking no action, or only limited action to implement voluntary educational or administrative tools.

Any new strategies and tools that are developed for Council review should also consider that not all residents feel there is an issue, and that many residents would like to preserve a high level of flexibility for new construction in the neighborhoods.

Annual Review

Any ordinance for adoption of one or more of the strategies and tools described in this report should include a provision requiring annual review of the impact of adopted tools. City staff would prepare an annual report with details on the use of the tools and possible recommendations to the Planning and Zoning Board and City Council for changes or revisions to streamline tools or promote more effective application. This annual review provision should apply for a period of three to five years with any additional future review occurring at longer intervals.

Other Strategies and Tools (not selected)

Part 3: "Potential Tools" on page 85 summarizes a wide range of tools that were considered to address the identified neighborhood issues and objectives. The suggested strategy options described above were selected by City staff and the consultant team in consultation with working group and community workshop participants because they:

- Best balance identified neighborhood objectives and issues (i.e., balancing the issue of new construction that appears to be overly large in relation to its context with the objective to preserve flexibility for change and reinvestment) as summarized in the table on page 119.
- Best meet criteria for fairness, predictability and effectiveness as described on page 112.
- Could be successfully implemented in the Eastside and Westside neighborhoods based on the consulting team's experience in peer communities.

Tools described in Part 3: "Potential Tools" on page 85 that were not included in the suggested strategy options could be reconsidered for further evaluation per direction from City Council.



Potential Future Strategies

As described below, other tools and strategies that are beyond the scope of the current Eastside and Westside Neighborhood character study, or would apply to properties outside of the project area, may also be considered to address neighborhood objectives and issues.

Address N-C-B Zoning

Some residents have expressed concern regarding the possibility of larger, higher density, construction replacing existing single-family structures in portions of the Laurel School National Register Historic District that are within the Neighborhood Conservation Buffer (N-C-B) zoning district.

The N-C-B district lies outside the scope of this study, but the City should continue to evaluate possible zoning adjustments to remove all or part of the historic district from the N-C-B zone to encourage more compatible redevelopment. Such adjustments may be best considered as part of a neighborhood planning process.

Address Other Zoning Boundaries

Some residents have indicated that neighborhood areas outside of the N-C-L and N-C-M zoning district experience similar issues and could benefit from the tools developed for this study.

The City should continue to evaluate zoning boundaries to ensure they are properly applied to address objectives and issues in centrally-located traditional neighborhoods. Such adjustments may be best considered as part of a neighborhood planning process. Updates to the neighborhood plans for the Eastside and Westside are currently on the City's work program for 2014.

Consider Citywide Application

Some residents indicated that the Eastside and Westside should not receive special consideration, and that any tools and strategies developed for the neighborhoods should be considered for other neighborhoods.

Once the Eastside and Westside Neighborhood Character study is complete, and selected strategies have been in place for a year or more, the City should review each tool for possible application in other neighborhoods and zone districts throughout the city.

Appendix A: GIS Mapping Data

GIS data was collected to visually portray the physical characteristics of the Eastside and Westside neighborhoods. This data helps to define the character of the neighborhoods as a whole, as well as to identify sub-areas with unique features. Eight maps for each of the neighborhoods are attached. The maps include:

- Building Age
- Building Remodels
- House Size
- Floor Area Ratio (FAR)
- Building Height
- Lot Size
- Lot Frontage
- Lot Coverage

Eastside Neighborhood: Building Age

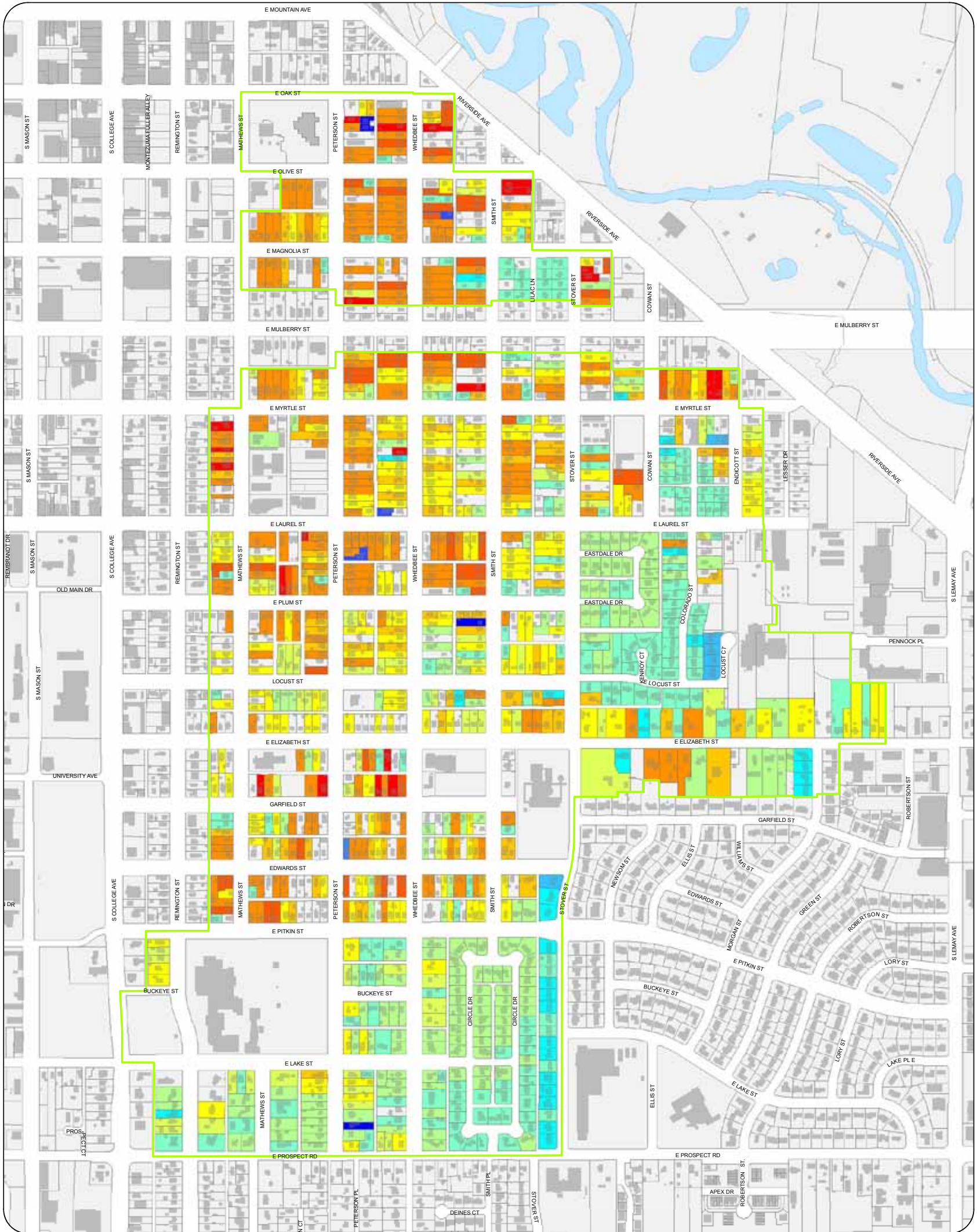

CITY OF FORT COLLINS
GEOGRAPHIC INFORMATION SYSTEM MAP PRODUCTS
 These map products and all underlying data are developed for use by the City of Fort Collins for its internal purposes only, and were not designed or intended for general use by members of the public. The City makes no representation or warranty as to the accuracy, timeliness, or completeness, and in particular, its accuracy in labeling or displaying dimensions, contours, property boundaries, or placement of location of any map features herein. THE CITY OF FORT COLLINS MAKES NO WARRANTY OF MERCHANTABILITY OR FITNESS FOR USE FOR PARTICULAR PURPOSE, EXPRESSED OR IMPLIED, WITH RESPECT TO THESE MAP PRODUCTS OR THE UNDERLYING DATA. Any users of these map products, map applications, or data, accept them AS IS, WITH ALL FAULTS, and assume all responsibility of use thereof, and further covenants and agrees to hold the City harmless from and against all damage, loss, or liability arising from any use of this map product, in consideration of the City's having made this information available. Independent verification of all data contained herein should be obtained by any users of these products, or underlying data. The City disclaims, and shall not be held liable for any and all damage, loss, or liability, whether direct, indirect, or consequential, which arises or may arise from these map products or the use thereof by any person or entity.

	Buildings	Year Built		1920		1970
	Water Features		Prior to 1890			1980
	Parcels		1890			1990
	City Limits		1900			2000 to Present
	Eastside Neighborhood		1910			



Printed: May 23, 2012

The Building Age map shows patterns in construction throughout the history of the neighborhood. In the Eastside the oldest areas are north of E. Mulberry Street and then moving south along Peterson, Whedbee and Smith Streets. These areas filled in slowly between the 1890s and the 1920s. The south and east portions of the neighborhood, near Circle Drive and Eastdale Drive, developed in a much shorter period of time in the 1950s and '60s, leading to less variety in building types in these areas. Recent construction (the darkest blue) is relatively sparse and scattered throughout the area.

Eastside Neighborhood: Building Remodels

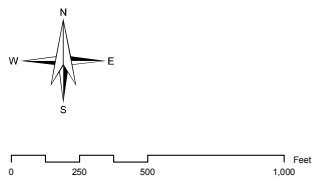
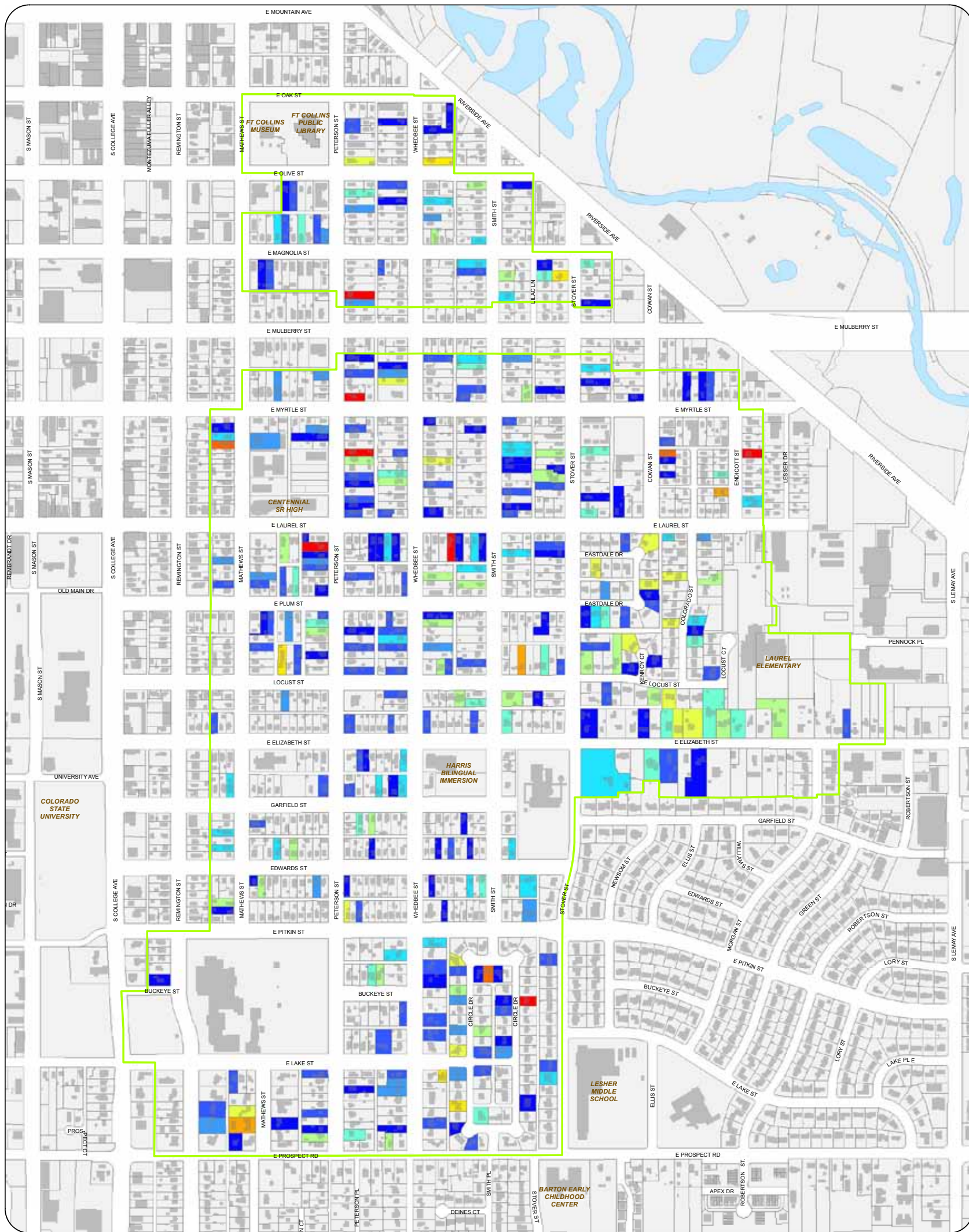

**CITY OF FORT COLLINS
GEOGRAPHIC INFORMATION SYSTEM MAP PRODUCTS**
 These map products and all underlying data are developed for use by the City of Fort Collins for its internal purposes only, and were not designed or intended for general use by members of the public. The City makes no representation or warranty as to its accuracy, timeliness, or completeness, and in particular, its accuracy in labeling or displaying dimensions, contours, property boundaries, or placement of location of any map features thereon. THE CITY OF FORT COLLINS MAKES NO WARRANTY OF MERCHANTABILITY OR FITNESS FOR USE FOR PARTICULAR PURPOSE, EXPRESSED OR IMPLIED, WITH RESPECT TO THESE MAP PRODUCTS OR THE UNDERLYING DATA. Any users of these map products, map applications, or data, accept them AS IS, WITH ALL FAULTS, and assumes all responsibility of the use thereof, and further covenants and agrees to hold the City harmless from and against all damage, loss, or liability arising from any use of this map product, in consideration of the City's having made this information available. Independent verification of all data contained herein should be obtained by any users of these products or underlying data. The City disclaims, and shall not be held liable for any and all damage, loss, or liability, whether direct, indirect, or consequential, which arises or may arise from these map products or the use thereof by any person or entity.

	Buildings	Year Remodeled		1970 - 1974		1990 - 1994
	Water Features		Prior to 1960			1995 - 1999
	Parcels		1960 - 1964			2000 - 2004
	City Limits		1965 - 1969			2005 to Present
	Eastside Neighborhood					



Printed: July 05, 2012

The Building Remodels map shows the years in which remodels of homes have occurred. This map shows that remodels have occurred throughout the history of the Eastside. However, the vast majority of them have occurred since 2000 (the darker shades of blue).

Eastside Neighborhood: House Size

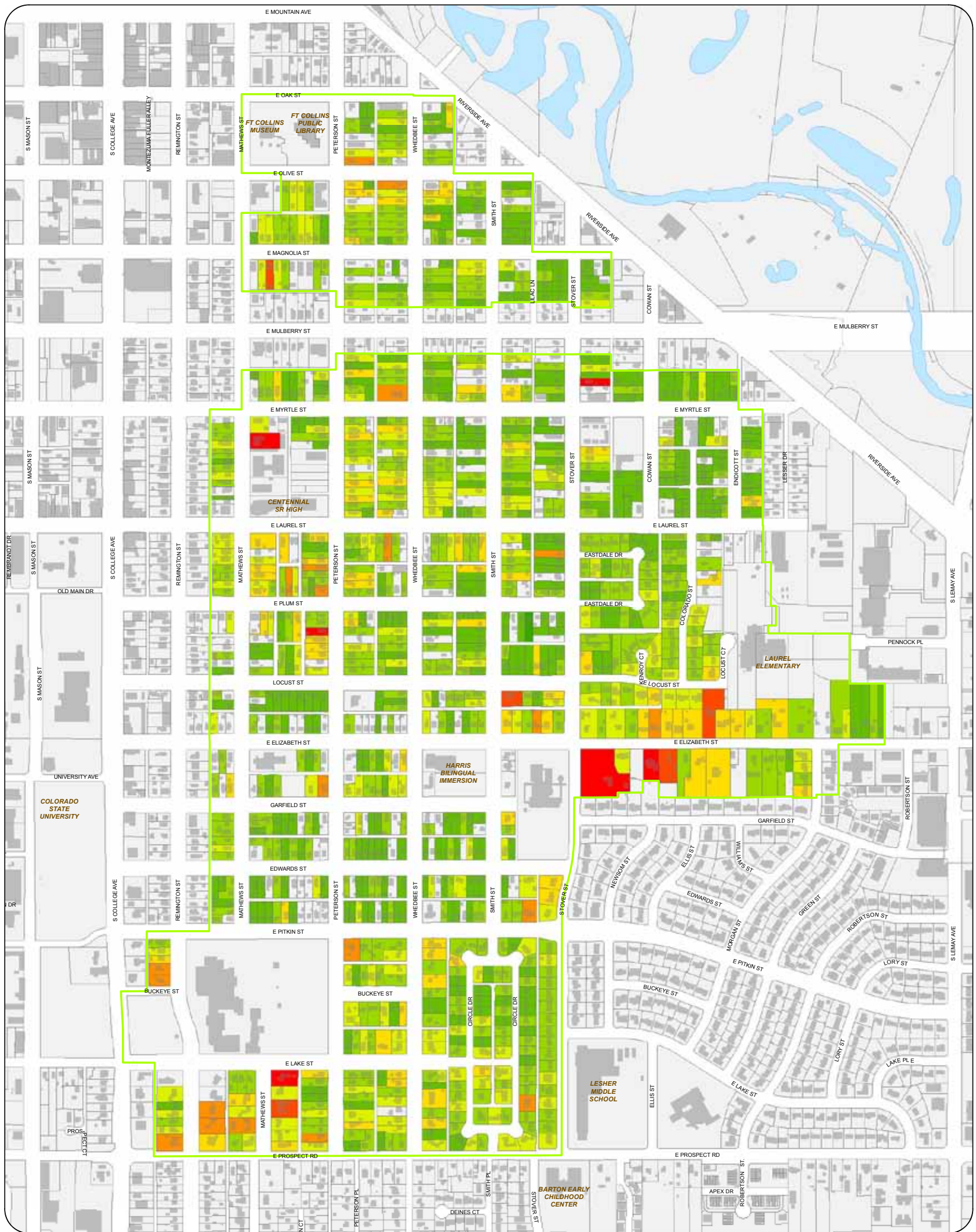

CITY OF FORT COLLINS
GEOGRAPHIC INFORMATION SYSTEM MAP PRODUCTS
 These map products and all underlying data are developed for use by the City of Fort Collins for its internal purposes only, and were not designed or intended for general use by members of the public. The City makes no representation or warranty as to the accuracy, timeliness, or completeness, and in particular, its accuracy in labeling or displaying dimensions, contours, property boundaries, or placement of location of any map features hereon. THE CITY OF FORT COLLINS MAKES NO WARRANTY OF MERCHANTABILITY OR WARRANTY FOR FITNESS OF USE FOR PARTICULAR PURPOSE, EXPRESSED OR IMPLIED, WITH RESPECT TO THESE MAP PRODUCTS OR THE UNDERLYING DATA. Any users of these map products, map applications, or data, accepts them AS IS, WITH ALL FAULTS, and assumes all responsibility of the use thereof, and further consents and agrees to hold the City harmless from and against all damage, loss, or liability arising from any use of this map product, in consideration of the City's having made this information available. Independent verification of all data contained herein should be obtained by any users of these products, or underlying data. The City disclaims, and shall not be held liable for any and all damage, loss, or liability, whether direct, indirect, or consequential, which arises or may arise from these map products or the use thereof by any person or entity.

	Buildings		1,000		2,500
	Water Features		1,500		3,000
	Parcels		2,000		3,500 +
	City Limits				
	Eastside Neighborhood				

	Less than 500
	500



Printed: July 05, 2012.

The House Size map shows patterns in the size of homes throughout the neighborhood. In the Eastside, the homes are predominantly 1,500 s.f. or less, with a few larger homes scattered throughout the area.

Eastside Neighborhood: Floor Area Ratio (FAR)

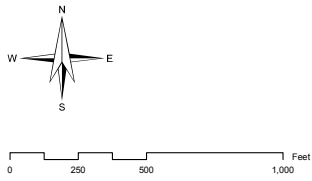
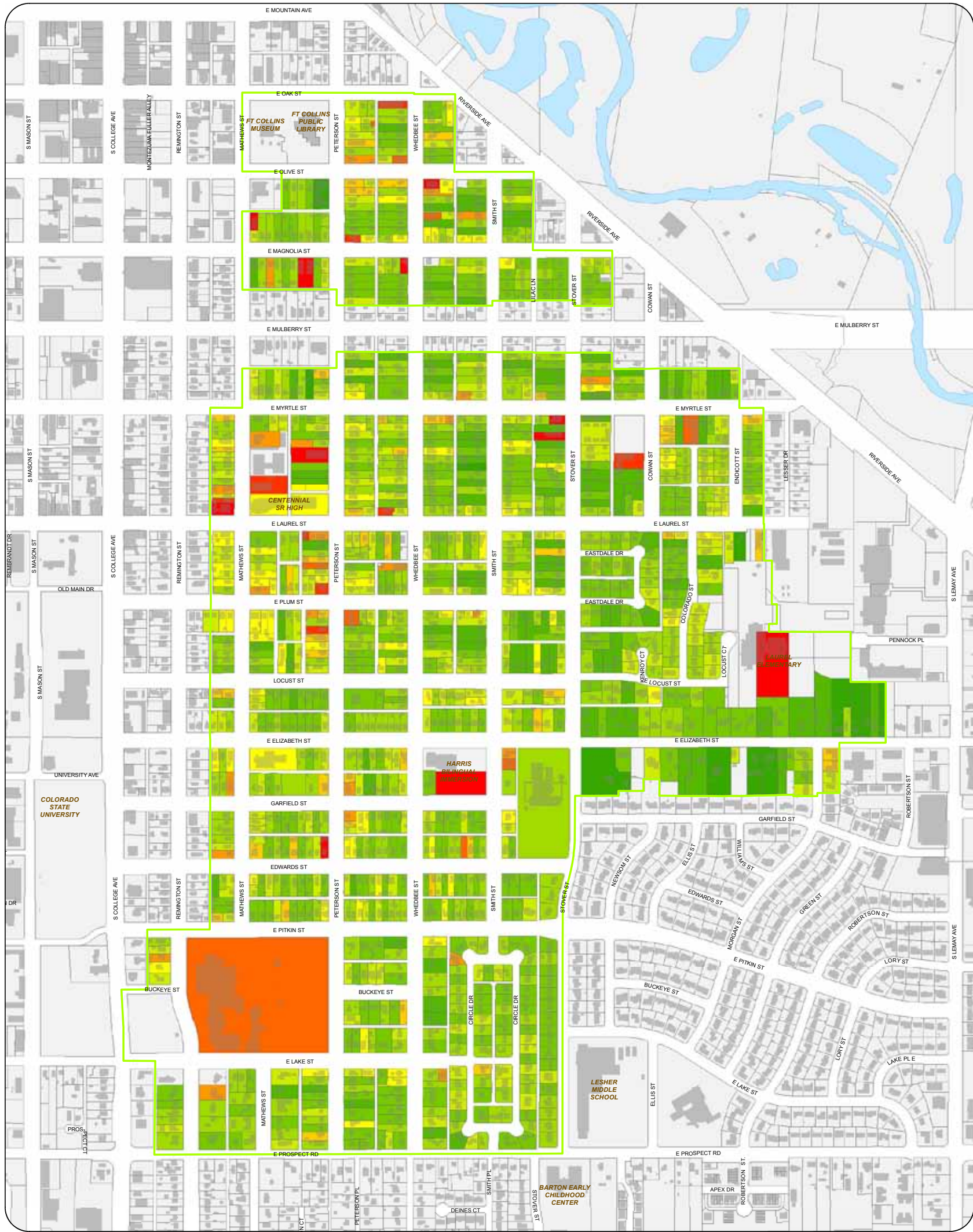

**CITY OF FORT COLLINS
GEOGRAPHIC INFORMATION SYSTEM MAP PRODUCTS**
 These map products and all underlying data are developed for use by the City of Fort Collins for its internal purposes only, and were not designed or intended for general use by members of the public. The City makes no representation or warranty as to the accuracy, timeliness, or completeness, and in particular, its accuracy in labeling or displaying dimensions, contours, property boundaries, or placement of location of any map features thereon. THE CITY OF FORT COLLINS MAKES NO WARRANTY OF MERCHANTABILITY OR WARRANTY OF FITNESS FOR PARTICULAR PURPOSE, EXPRESSED OR IMPLIED, WITH RESPECT TO THESE MAP PRODUCTS OR THE UNDERLYING DATA. Any users of these map products, map applications, or data, accept them AS-IS, WITH ALL FAULTS, and assumes all responsibility of the use thereof, and further covenants and agrees to hold the City harmless from and against all damage, loss, or liability arising from any use of this map product, in consideration of the City's having made this information available. Independent verification of all data contained herein should be obtained by any users of these products or underlying data. The City disclaims, and shall not be held liable for any and all damage, loss, or liability, whether direct, indirect, or consequential, which arises or may arise from these map products or the use thereof by any person or entity.

	Buildings	Floor Area Ratio			0.16 - 0.20		0.36 - 0.40
	Water Features		0.03 - 0.05		0.21 - 0.25		0.41 - 0.45
	Parcels		0.06 - 0.10		0.26 - 0.30		0.46 - 0.50
	City Limits		0.11 - 0.15		0.31 - 0.35		0.51 - 1.18
	Eastside Neighborhood						



Printed: July 05, 2012.

The Floor Area Ratio (FAR) map shows patterns in the FAR of homes throughout the neighborhood. In the Eastside, the homes predominantly have an FAR of 0.25 or less, with a few homes with larger FARs scattered throughout the area.

Eastside Neighborhood: Building Height

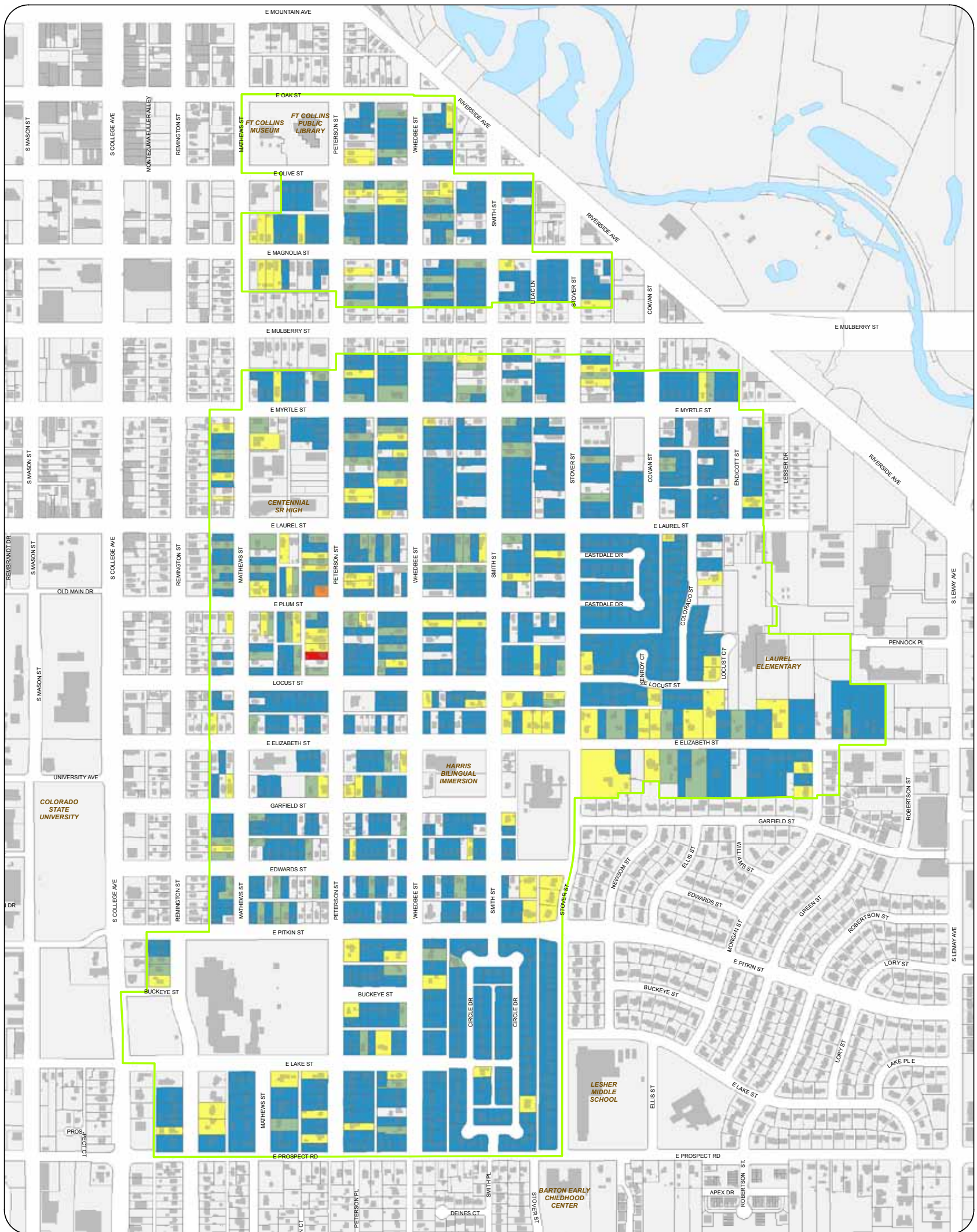

0 250 500 1,000 Feet

CITY OF FORT COLLINS
GEOGRAPHIC INFORMATION SYSTEM MAP PRODUCTS
 These map products and all underlying data are developed for use by the City of Fort Collins for its internal purposes only, and were not designed or intended for general use by members of the public. The City makes no representation or warranty as to the accuracy, timeliness, or completeness, and in particular, its accuracy in labeling or depicting dimensions, contours, property boundaries, or placement of location of any map features herein. THE CITY OF FORT COLLINS MAKES NO WARRANTY OF MERCHANTABILITY OR WARRANTY FOR FITNESS FOR USE FOR PARTICULAR PURPOSE, EXPRESSED OR IMPLIED, WITH RESPECT TO THESE MAP PRODUCTS OR THE UNDERLYING DATA. Any uses of these map products, map applications, or data, except those AGED, WITH ALL FAULTS, and assumes all responsibility of the use thereof, and further covenants and agrees to hold the City harmless from and against all damage, loss, or liability arising from any use of the map product. In consideration of the City's having made this information available, independent verification of all data contained herein should be obtained by any users of these products, or underlying data. The City disclaims, and shall not be held liable for any and all damage, loss, or liability, whether direct, indirect, or consequential, which arises or may arise from these map products or the use thereof by any person or entity.

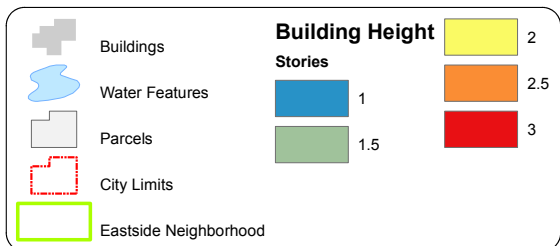

Printed: July 05, 2012

The Building Height map shows patterns in the height of homes throughout the neighborhood. In the Eastside, the homes are predominantly one story. Several more are one-and-a-half and two story, and only two are taller than two stories.

Eastside Neighborhood: Lot Size

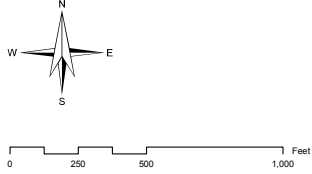
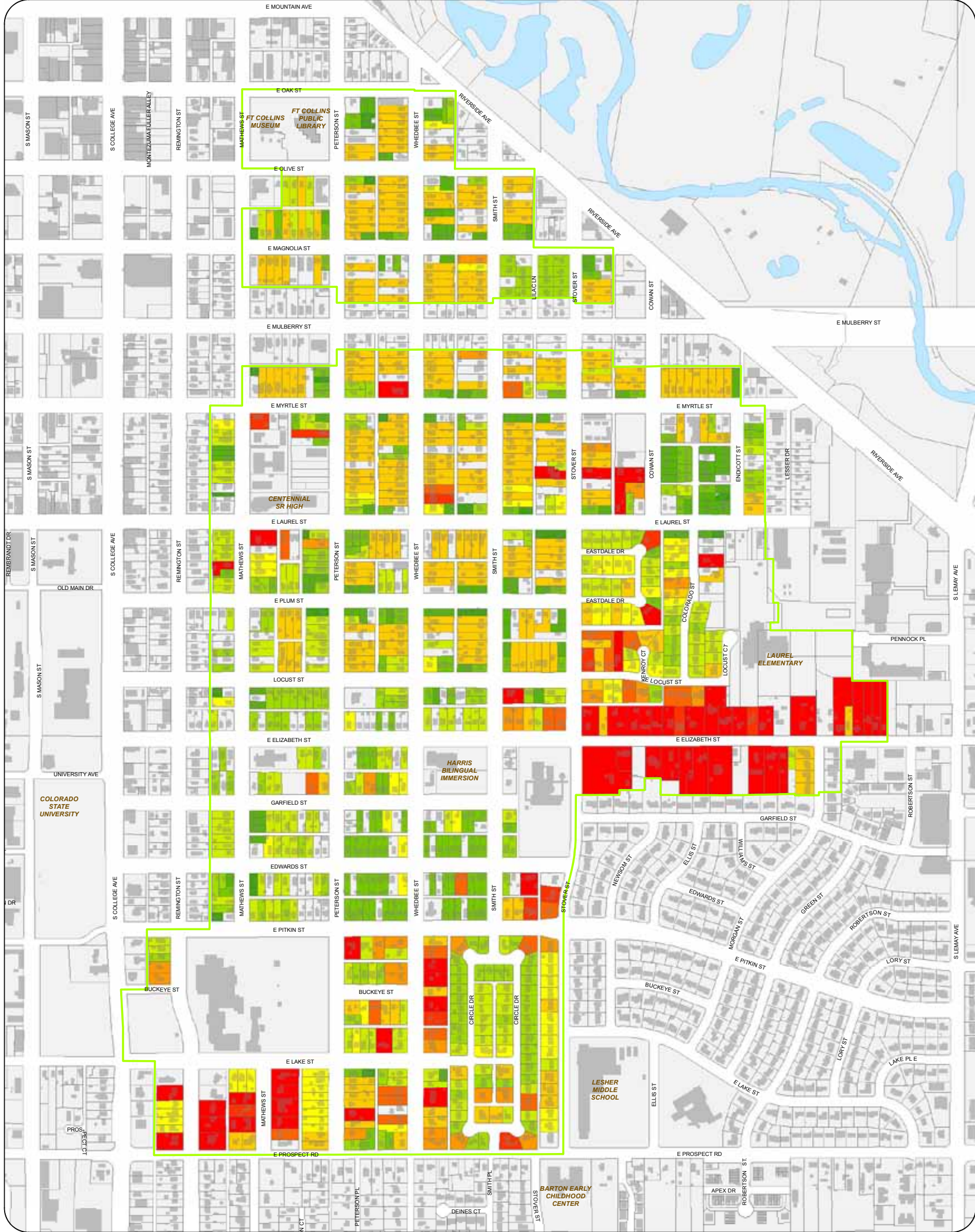

CITY OF FORT COLLINS
 GEOGRAPHIC INFORMATION SYSTEM MAP PRODUCTS
 These map products and all underlying data are developed for use by the City of Fort Collins for its internal purposes only, and were not designed or intended for general use by members of the public. The City makes no representation or warranty as to the accuracy, timeliness, or completeness, and in particular its accuracy in labeling or displaying dimensions, contours, property boundaries, or placement of location of any map features thereon. THE CITY OF FORT COLLINS MAKES NO WARRANTY OF MERCHANTABILITY OR WARRANTY OF FITNESS FOR USE FOR PARTICULAR PURPOSE, EXPRESSED OR IMPLIED, WITH RESPECT TO THESE MAP PRODUCTS OR THE UNDERLYING DATA. Any users of these map products, map applications, or data, accept them AS IS, WITH ALL FAULTS, and assumes all responsibility of the use thereof, and further covenants and agrees to hold the City harmless from and against all damage, loss, or liability arising from any use of this map product. In consideration of the City's having made this information available, independent verification of all data contained herein should be obtained by any users of these products, or underlying data. The City disclaims, and shall not be held liable for any and all damage, loss, or liability, whether direct, indirect, or consequential, which arises or may arise from these map products or the use thereof by any person or entity.

	Buildings		
	Water Features		
	Parcels		
	City Limits		
	Eastside Neighborhood		

Lot Size		Square Feet	
	Less than 4,000		6,000
	4,000		7,000
	5,000		8,000
			9,000
			10,000
			11,000
			12,000
			13,000 +



Printed: July 05, 2012

The Lot Size map shows patterns in square-footage of lots throughout the neighborhood. In the Eastside, most blocks have a predominant lot size, with the exception of curvilinear street patterns and smaller or subdivided corner lots.

Eastside Neighborhood: Lot Frontage

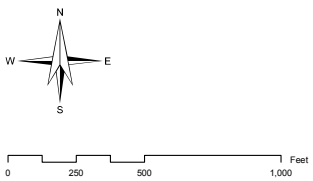
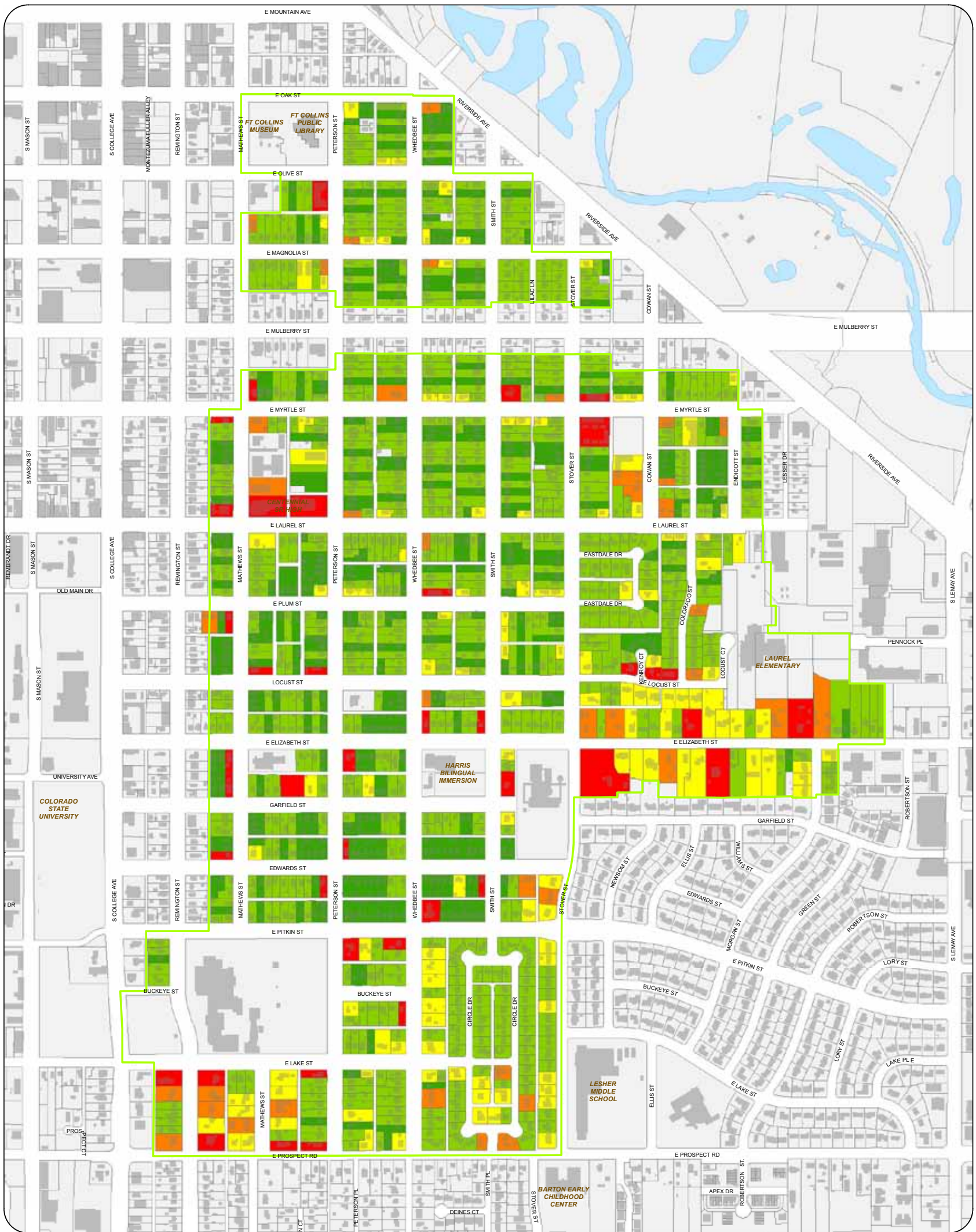

**CITY OF FORT COLLINS
GEOGRAPHIC INFORMATION SYSTEM MAP PRODUCTS**

These map products and all underlying data are developed for use by the City of Fort Collins for its internal purposes only, and were not designed or intended for general use by members of the public. The City makes no representation or warranty as to its accuracy, timeliness, or completeness, and in particular, its accuracy in labeling or displaying dimensions, contours, property boundaries, or placement of location of any map features shown. THE CITY OF FORT COLLINS MAKES NO WARRANTY OF MERCHANTABILITY OR WARRANTY FOR FITNESS OF USE FOR PARTICULAR PURPOSE, EXPRESSED OR IMPLIED, WITH RESPECT TO THESE MAP PRODUCTS OR THE UNDERLYING DATA. Any uses of these map products, map applications, or data, except those AS IS, WITH ALL FAILS, and assumes all responsibility of the use thereof, and further covenants and agrees to hold the City harmless from and against all damage, loss, or liability arising from any use of the map product. In consideration of the City's having made this information available, independent verification of all data contained herein should be obtained by any users of these products, or underlying data. The City disclaims, and shall not be held liable for any and all damage, loss, or liability, whether direct, indirect, or consequential, which arises or may arise from these map products or the use thereof by any person or entity.

	Buildings		76 - 100
	Water Features		101 - 125
	Parcels		More than 125
	City Limits		25 - 50
	Eastside Neighborhood		51 - 75



Printed: July 05, 2012

The Lot Frontage map shows patterns in width of lots throughout the neighborhood. Combined with lot size, the frontage will help determine if a lot may legally be subdivided. In the Eastside, lot frontage is typically 75 feet or less. Exceptions occur on corner lots, along curvilinear streets, and near E. Elizabeth Drive and Mathews Street where larger lot patterns occur.

Eastside Neighborhood: Lot Coverage

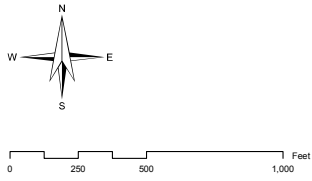
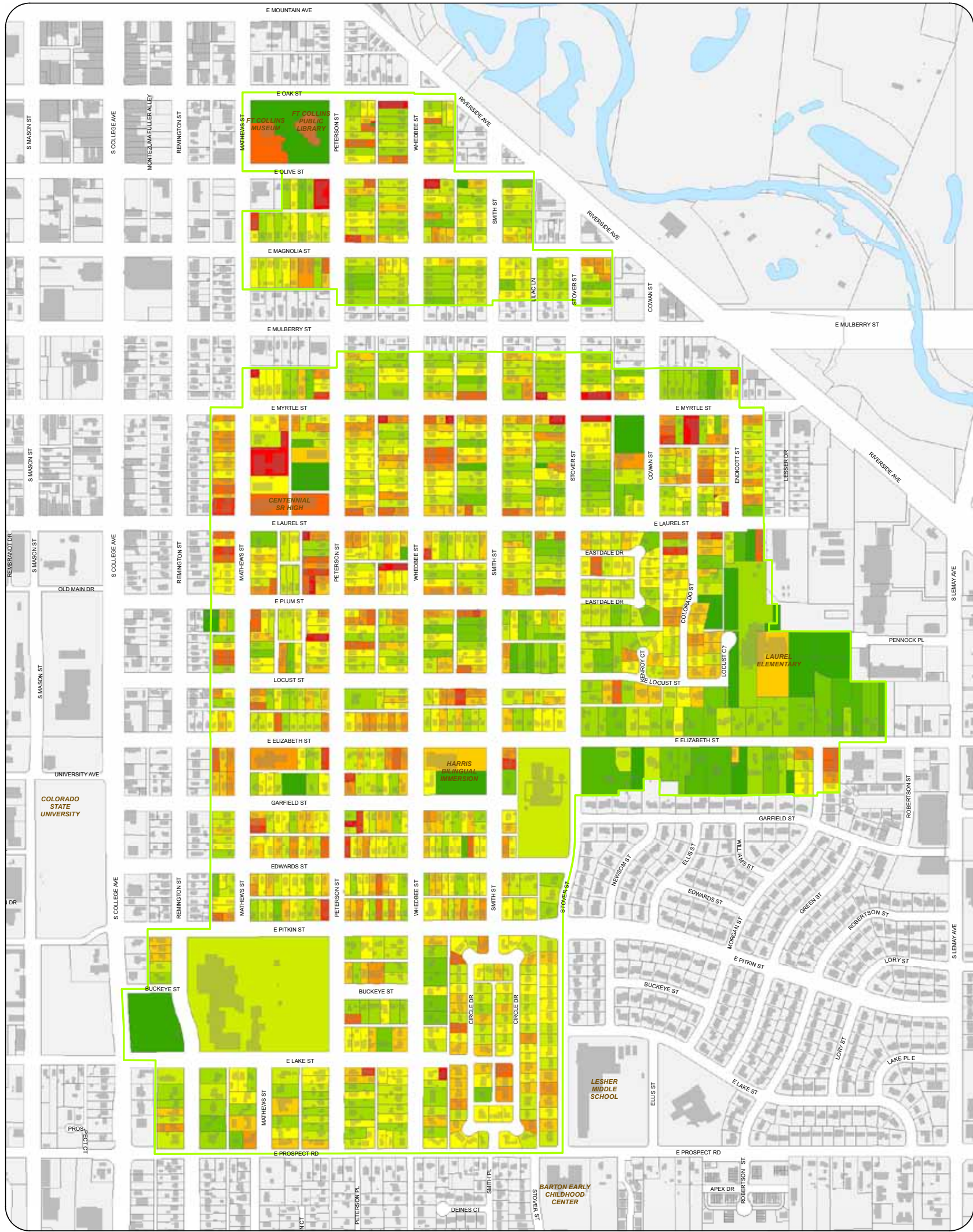

**CITY OF FORT COLLINS
GEOGRAPHIC INFORMATION SYSTEM MAP PRODUCTS**
 These map products and all underlying data are developed for use by the City of Fort Collins for its internal purposes only, and were not designed or intended for general use by members of the public. The City makes no representation or warranty as to its accuracy, timeliness, or completeness, and in particular, its accuracy in labeling or displaying dimensions, contours, property boundaries, or placement of location of any map features thereon. THE CITY OF FORT COLLINS MAKES NO WARRANTY OF MERCHANTABILITY OR WARRANTY OF FITNESS FOR USE FOR PARTICULAR PURPOSE, EXPRESSED OR IMPLIED, WITH RESPECT TO THESE MAP PRODUCTS OR THE UNDERLYING DATA. Any users of these products, map applications, or data, accepts them AS-IS, WITH ALL FAULTS, and assumes all responsibility of the use thereof, and further covenants and agrees to hold the City harmless from and against all damage, loss, or liability arising from any use of this map product, in consideration of the City's having made this information available. Independent verification of all data contained herein should be obtained by any users of these products or underlying data. The City disclaims, and shall not be held liable for any and all damage, loss, or liability, whether direct, indirect, or consequential, which arises or may arise from these map products or the use thereof by any person or entity.

Buildings		Water Features		Parcels		City Limits		Eastside Neighborhood	
[Symbol]	Buildings	[Symbol]	Water Features	[Symbol]	Parcels	[Symbol]	City Limits	[Symbol]	Eastside Neighborhood

Lot Coverage			
[Green]	Less than 5%	[Light Green]	15% - 19%
[Light Green]	5% - 9%	[Yellow-Green]	20% - 24%
[Yellow-Green]	10% - 14%	[Yellow]	25% - 29%
[Yellow]		[Light Orange]	30% - 34%
		[Orange]	35% - 39%
		[Dark Orange]	40% - 44%
		[Red-Orange]	45% - 49%
		[Red]	50% +



Printed: July 05, 2012

The Lot Coverage map shows patterns in percentage of covered lot throughout the neighborhood. Lot coverage typically varies throughout each block in the Eastside. Most lots are less than 50% covered.

Westside Neighborhood: Building Age

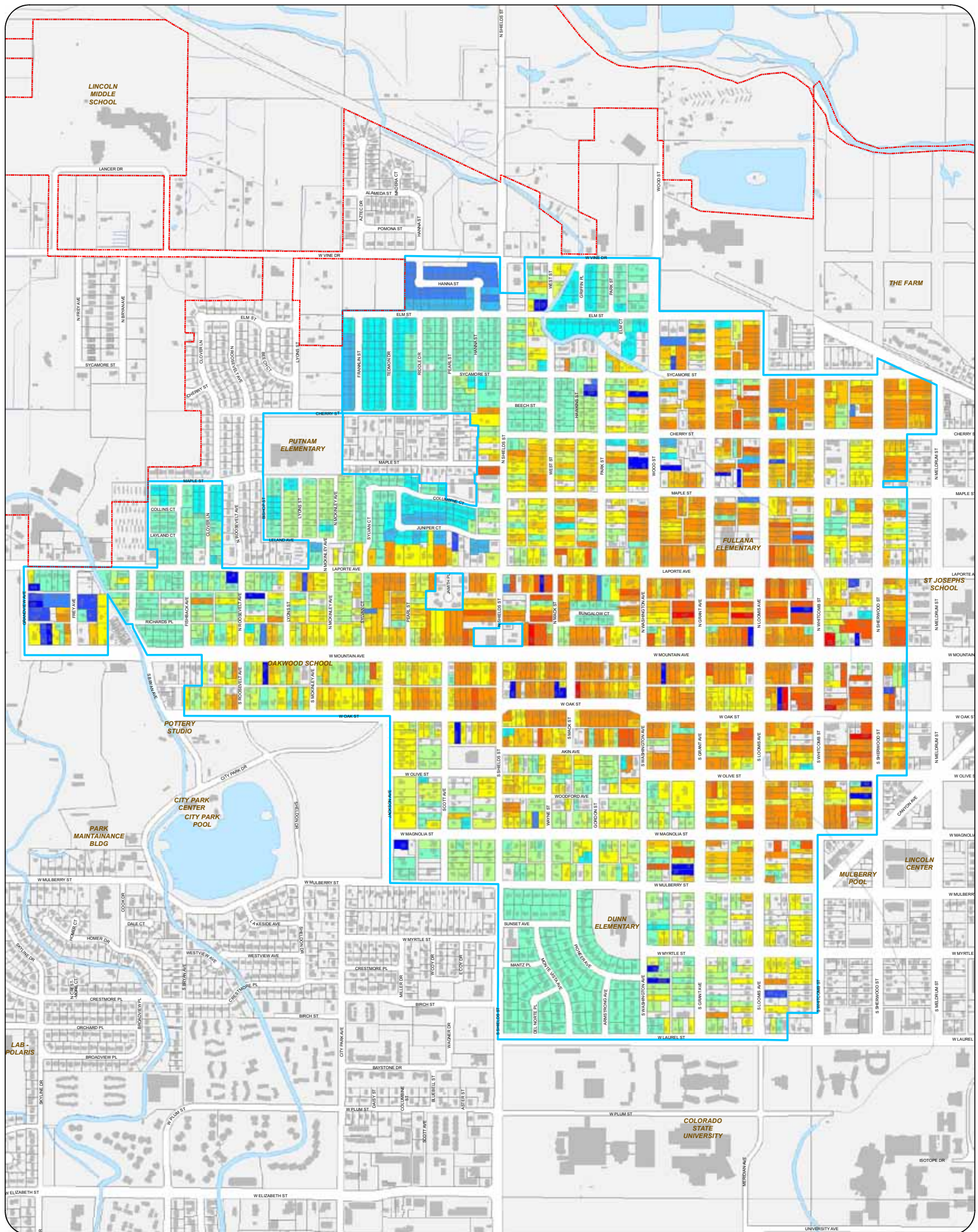

0 500 1,000 2,000 Feet

CITY OF FORT COLLINS
GEOGRAPHIC INFORMATION SYSTEM MAP PRODUCTS

These map products and all underlying data are developed for use by the City of Fort Collins for its internal purposes only, and were not designed or intended for general use by members of the public. The City makes no representation or warranty as to the accuracy, timeliness, or completeness, and in particular, its accuracy in labeling or depicting dimensions, contours, property boundaries, or placement of location of any map features shown. THE CITY OF FORT COLLINS MAKES NO WARRANTY OF MERCHANTABILITY OR FITNESS FOR FITNESS OF USE FOR PARTICULAR PURPOSE, EXPRESSED OR IMPLIED, WITH RESPECT TO THESE MAP PRODUCTS OR THE UNDERLYING DATA. Any uses of these map products, map applications, or data, except those AS IS, WITH ALL FAILS, and assumes all responsibility of the use thereof, and further covenants and agrees to hold the City harmless from and against all damage, loss, or liability arising from any use of this map product. In consideration of the City's having made this information available, independent verification of all data contained herein should be obtained by any users of these products, or underlying data. The City disclaims, and shall not be held liable for any and all damage, loss, or liability, whether direct, indirect, or consequential, which arises or may arise from these map products or the use thereof by any person or entity.

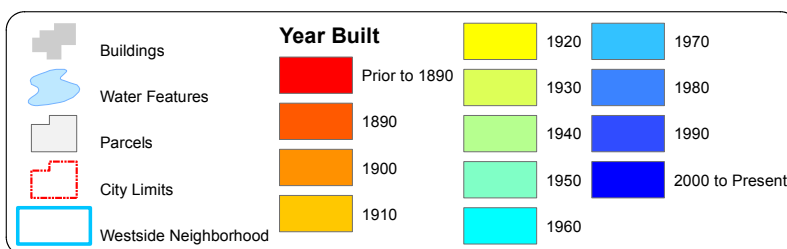

Printed: July 05, 2012

The Building Age map shows patterns in construction throughout the history of the neighborhood. In the Westside, the oldest areas spread out along W. Mountain Avenue and the areas closest to downtown. These areas filled in slowly between the 1890s and the 1920s. The edges of the neighborhood furthest from downtown developed in much shorter periods of time between the 1940s and the 1960s, leading to less variety in building types in these areas. Recent construction (the darkest blue) is scattered throughout the area and most lots are within a four-block radius of recent construction.

Westside Neighborhood: Building Remodels

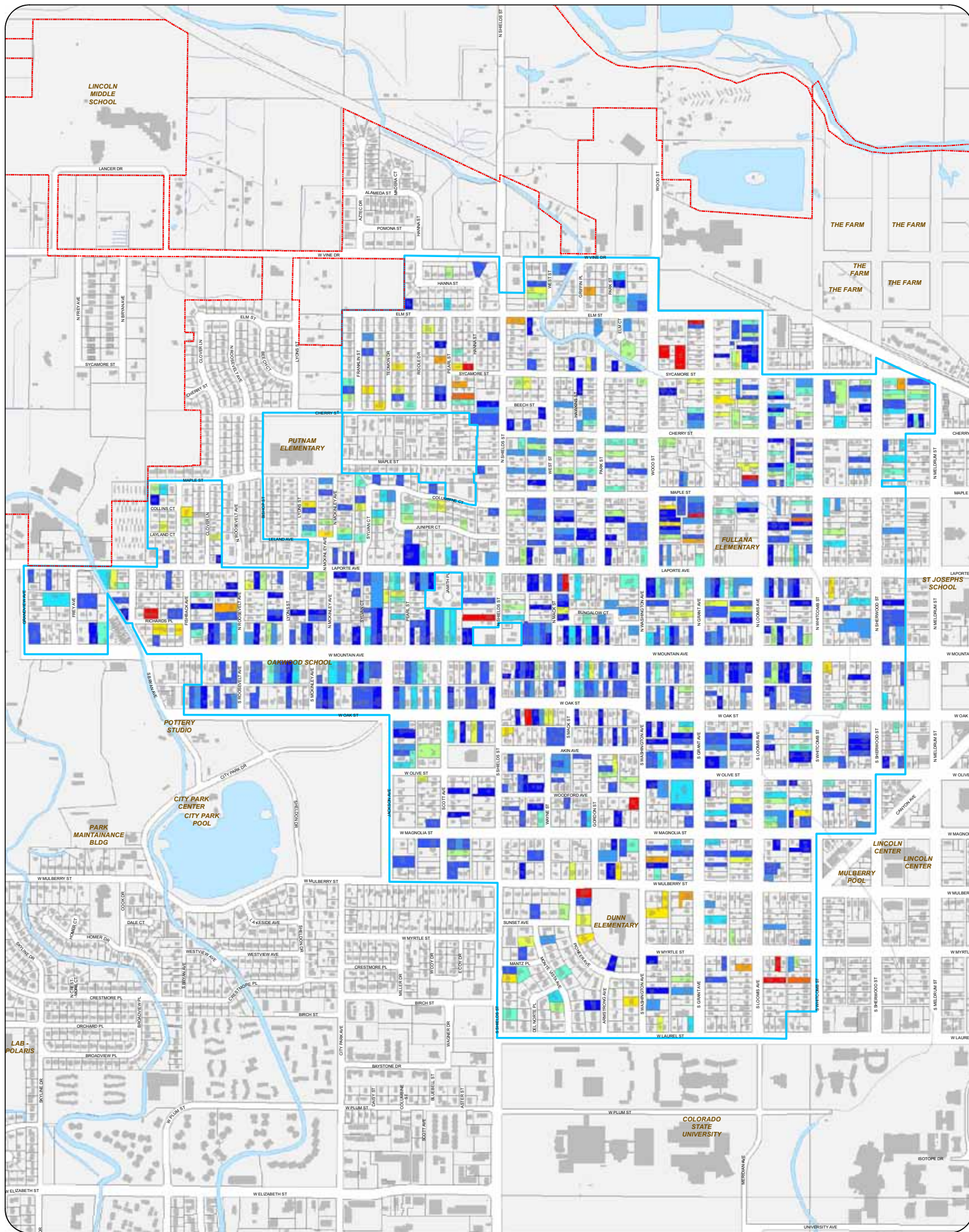

0 500 1,000 2,000 Feet

CITY OF FORT COLLINS
GEOGRAPHIC INFORMATION SYSTEM MAP PRODUCTS
 These map products and all underlying data are developed for use by the City of Fort Collins for its internal purposes only, and were not designed or intended for general use by members of the public. The City makes no representation or warranty as to its accuracy, timeliness, or completeness, and in particular, its accuracy in labeling or displaying dimensions, contours, property boundaries, or placement of location of any map features thereon. THE CITY OF FORT COLLINS MAKES NO WARRANTY OF MERCHANTABILITY OR FITNESS FOR USE FOR PARTICULAR PURPOSE, EXPRESSED OR IMPLIED, WITH RESPECT TO THESE MAP PRODUCTS OR THE UNDERLYING DATA. Any use of these map products, map applications, or data, except those AS IS, WITH ALL FAULTS, and assumes all responsibility of the use thereof, and further covenants and agrees to hold the City harmless from and against all damage, loss, or liability arising from any use of the map products, in consideration of the City's having made this information available. Independent verification of all data contained herein should be obtained by any users of these products or underlying data. The City disclaims, and shall not be held liable for any and all damage, loss, or liability, whether direct, indirect, or consequential, which arises or may arise from these map products or the use thereof by any person or entity.

	Buildings		Prior to 1960		1970 - 1974		1990 - 1994
	Water Features		1960 - 1964		1975 - 1979		1995 - 1999
	Parcels		1965 - 1969		1980 - 1984		2000 - 2004
	City Limits				1985 - 1989		2005 to Present
	Westside Neighborhood						



Printed: July 05, 2012

The Building Remodels map shows the years in which remodels of homes have occurred. This map shows that remodels have occurred throughout the history of the Westside. However, the vast majority of them have occurred since 2000 (the darker shades of blue). Recent remodels are also heavily concentrated along or near W. Mountain Avenue.

Westside Neighborhood: House Size

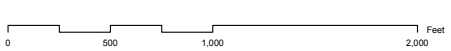
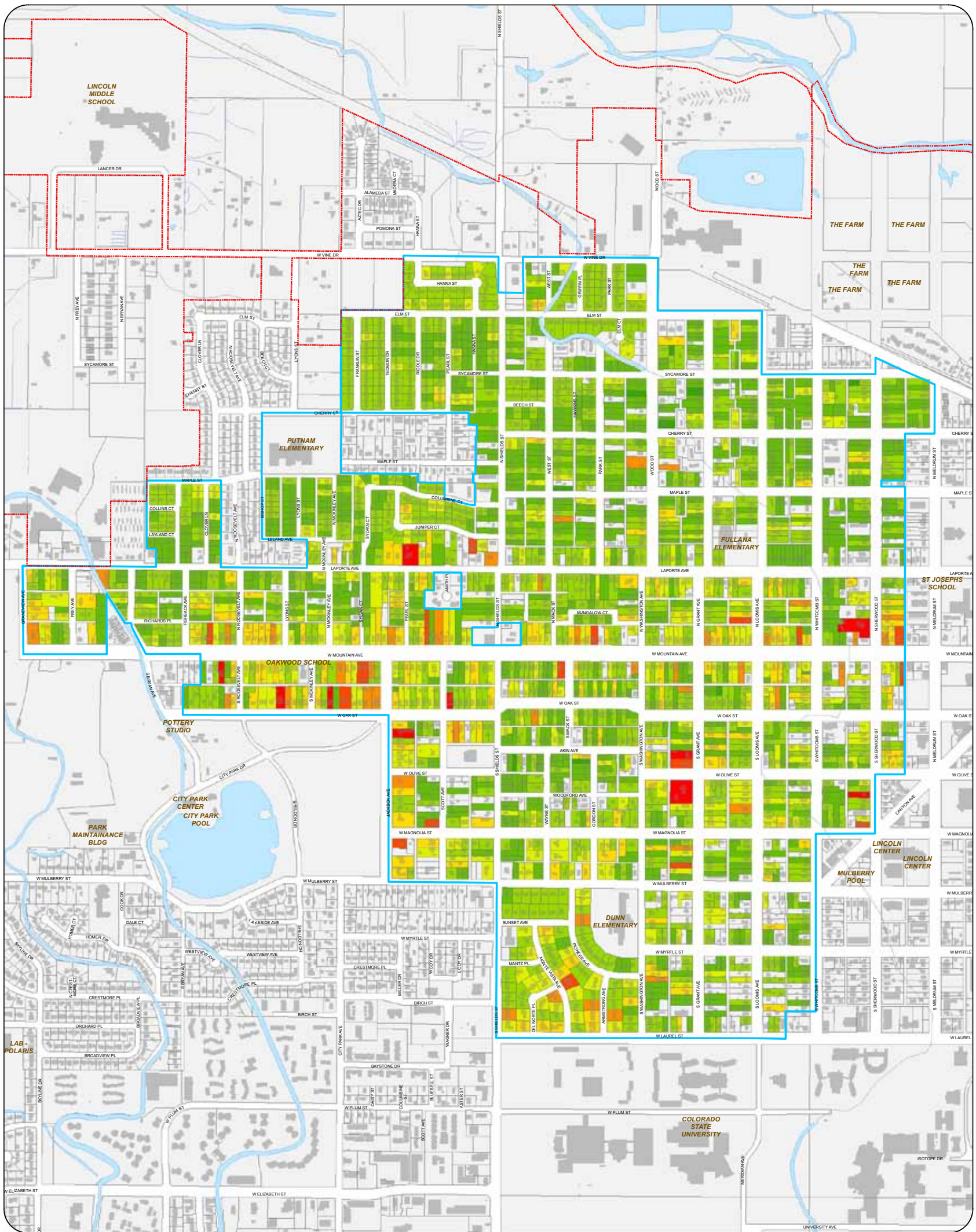

**CITY OF FORT COLLINS
GEOGRAPHIC INFORMATION SYSTEM MAP PRODUCTS**
These map products and all underlying data are developed for use by the City of Fort Collins for its internal purposes only, and were not designed or intended for general use by members of the public. The City makes no representation or warranty as to its accuracy, timeliness, or completeness, and in particular, its accuracy in labeling or depicting dimensions, contours, property boundaries, or placement of location of any map features shown. THE CITY OF FORT COLLINS MAKES NO WARRANTY OF MERCHANTABILITY OR FITNESS FOR FITNESS OF USE FOR PARTICULAR PURPOSE, EXPRESSED OR IMPLIED, WITH RESPECT TO THESE MAP PRODUCTS OR THE UNDERLYING DATA. Any uses of these map products, map applications, or data, accept these AS IS, WITH ALL FAILS, and assumes all responsibility of the use thereof, and further covenants and agrees to hold the City harmless from and against all damage, loss, or liability arising from any use of this map product, in consideration of the City's having made this information available. Independent verification of all data contained herein should be obtained by any users of these products, or underlying data. The City disclaims, and shall not be held liable for any and all damage, loss, or liability, whether direct, indirect, or consequential, which arises or may arise from these map products or the use thereof by any person or entity.

	Buildings	House Size			
	Water Features	Square Feet			
	Parcels		Less than 500		1,000
	City Limits		500		1,500
	Westside Neighborhood				2,000
					2,500
					3,000
					3,500 +



Printed: July 05, 2012

The House Size map shows patterns in the size of homes throughout the neighborhood. In the Westside, homes are predominantly similar in size along a block and 1,500 s.f. or less. However, along W. Mountain Avenue the average house size is larger and varies more across an individual block.

Westside Neighborhood: Floor Area Ratio (FAR)

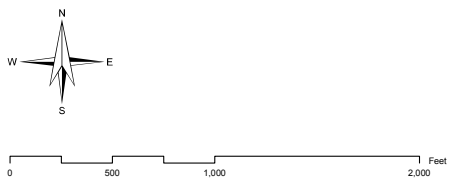
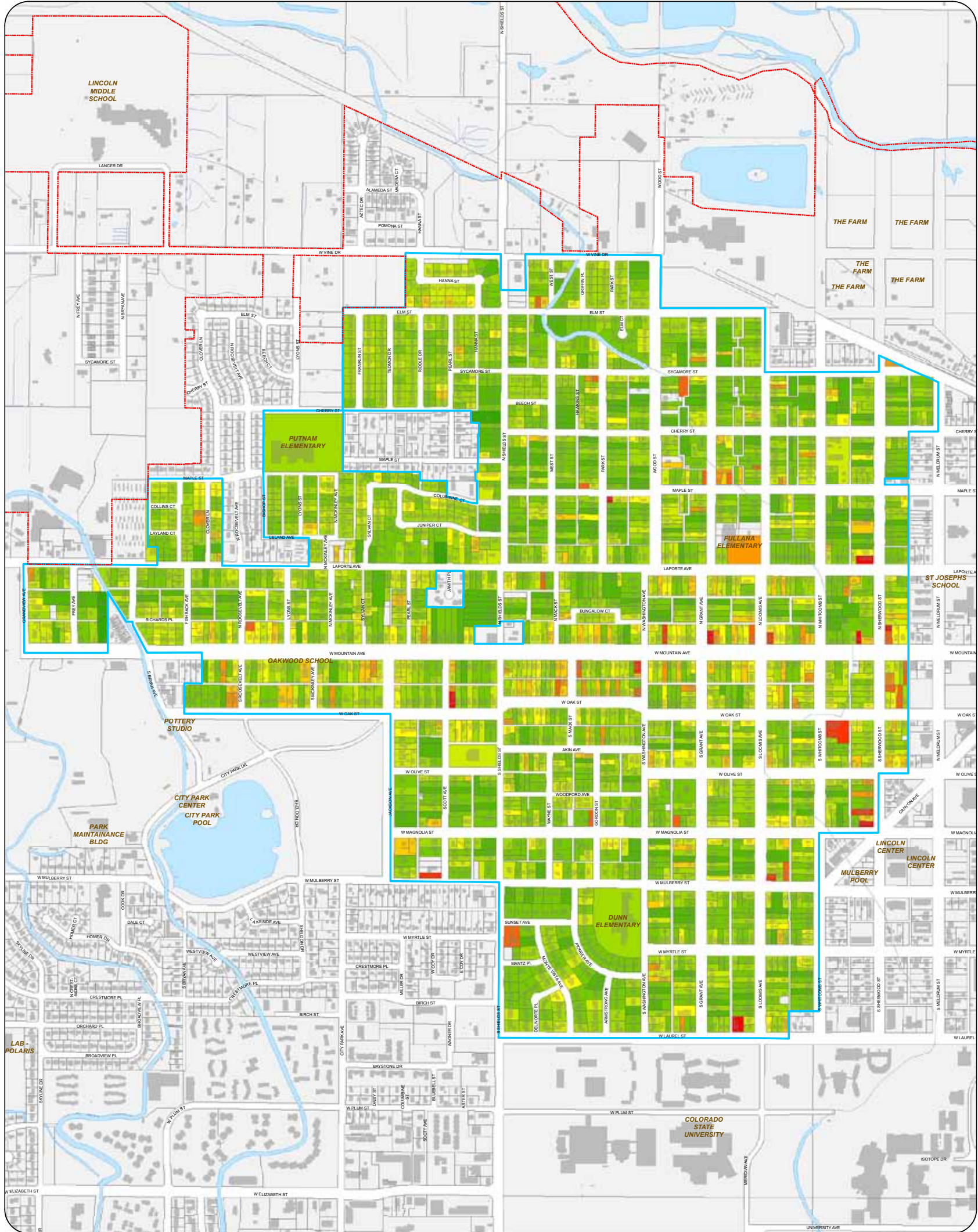

CITY OF FORT COLLINS
GEOGRAPHIC INFORMATION SYSTEM MAP PRODUCTS
 These map products and all underlying data are developed for use by the City of Fort Collins for its internal purposes only, and were not designed or intended for general use by members of the public. The City makes no representation or warranty as to the accuracy, timeliness, or completeness, and in particular its accuracy in labeling or displaying dimensions, contours, property boundaries, or placement of location of any map features thereon. THE CITY OF FORT COLLINS MAKES NO WARRANTY OF MERCHANTABILITY OR WARRANTY OF FITNESS FOR USE FOR PARTICULAR PURPOSE, EXPRESSED OR IMPLIED, WITH RESPECT TO THESE MAP PRODUCTS OR THE UNDERLYING DATA. Any use of these map products, map applications, or data, except those AS IS, WITH ALL FAULTS, and assumes all responsibility of the user thereof, and further warrants and agrees to hold the City harmless from and against all damage, loss, or liability arising from any use of the map product. In consideration of the City's having made this information available, independent verification of all data contained herein should be obtained by any users of these products or underlying data. The City disclaims, and shall not be held liable for any and all damage, loss, or liability, whether direct, indirect, or consequential, which arises or may arise from these map products or the use thereof by any person or entity.

	Buildings		0.03 - 0.05		0.16 - 0.20		0.36 - 0.40
	Water Features		0.06 - 0.10		0.21 - 0.25		0.41 - 0.45
	Parcels		0.11 - 0.15		0.26 - 0.30		0.46 - 0.50
	City Limits				0.31 - 0.35		0.51 - 1.18
	Westside Neighborhood						



Printed: July 05, 2012

The Floor Area Ratio (FAR) map shows patterns in the FAR of homes throughout the neighborhood. In the Westside, homes predominantly have an FAR of 0.25 or less, with a few homes of larger FARs scattered throughout the area. Along and near W. Mountain Avenue average FARs are larger and vary more across an individual block.

Westside Neighborhood: Building Height

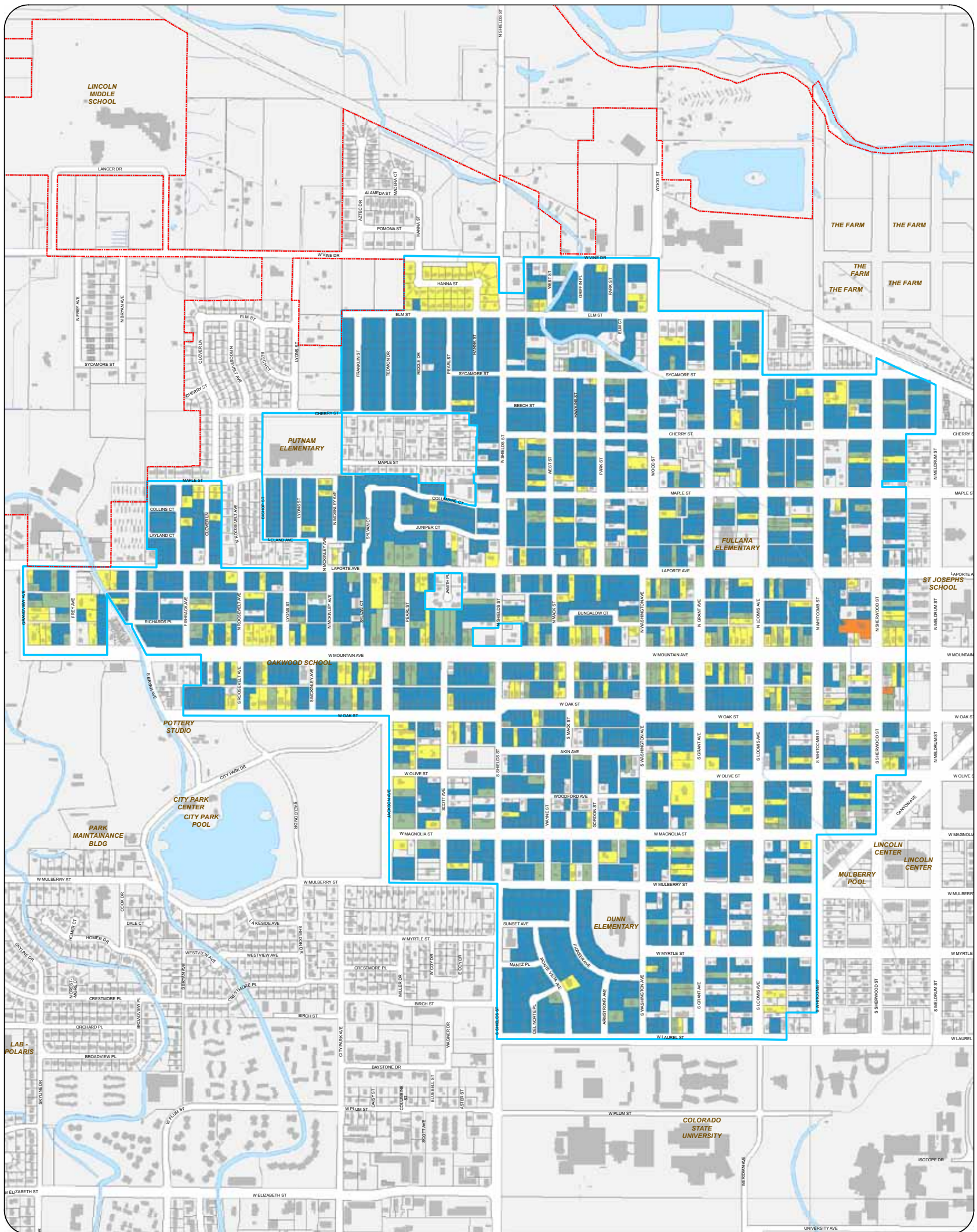

0 500 1,000 2,000 Feet

**CITY OF FORT COLLINS
GEOGRAPHIC INFORMATION SYSTEM MAP PRODUCTS**
These map products and all underlying data are developed for use by the City of Fort Collins for its internal purposes only, and were not designed or intended for general use by members of the public. The City makes no representation or warranty as to its accuracy, timeliness, or completeness, and in particular, its accuracy in labeling or displaying dimensions, contours, property boundaries, or placement of location of any map features thereon. THE CITY OF FORT COLLINS MAKES NO WARRANTY OF MERCHANTABILITY OR WARRANTY FOR FITNESS OF USE FOR PARTICULAR PURPOSE, EXPRESSED OR IMPLIED, WITH RESPECT TO THESE MAP PRODUCTS OR THE UNDERLYING DATA. Any uses of these map products, map applications, or data, except those AS IS, WITH ALL FAILS, and assumes all responsibility of the use thereof, and further covenants and agrees to hold the City harmless from and against all damage, loss, or liability arising from any use of this map product, in consideration of the City's having made this information available. Independent verification of all data contained herein should be obtained by any users of these products, or underlying data. The City disclaims, and shall not be held liable for any and all damage, loss, or liability, whether direct, indirect, or consequential, which arises or may arise from these map products or the use thereof by any person or entity.

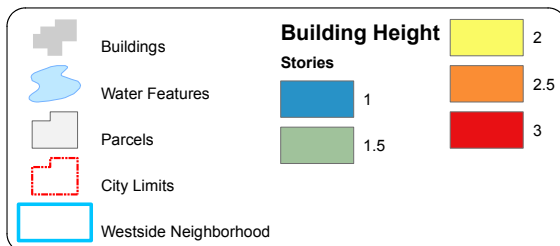

Printed: July 05, 2012

The Building Height map shows patterns in the height of homes throughout the neighborhood. In the Westside, homes are typically one story, with scattered one-and-a-half and two story as well. Along and near W. Mountain Avenue average heights are taller, typically at one-and-a-half stories with several two-story homes as well.

Westside Neighborhood: Lot Size

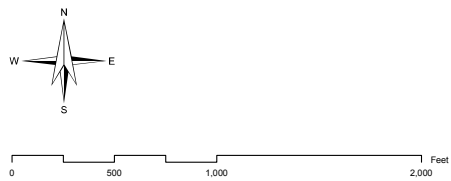
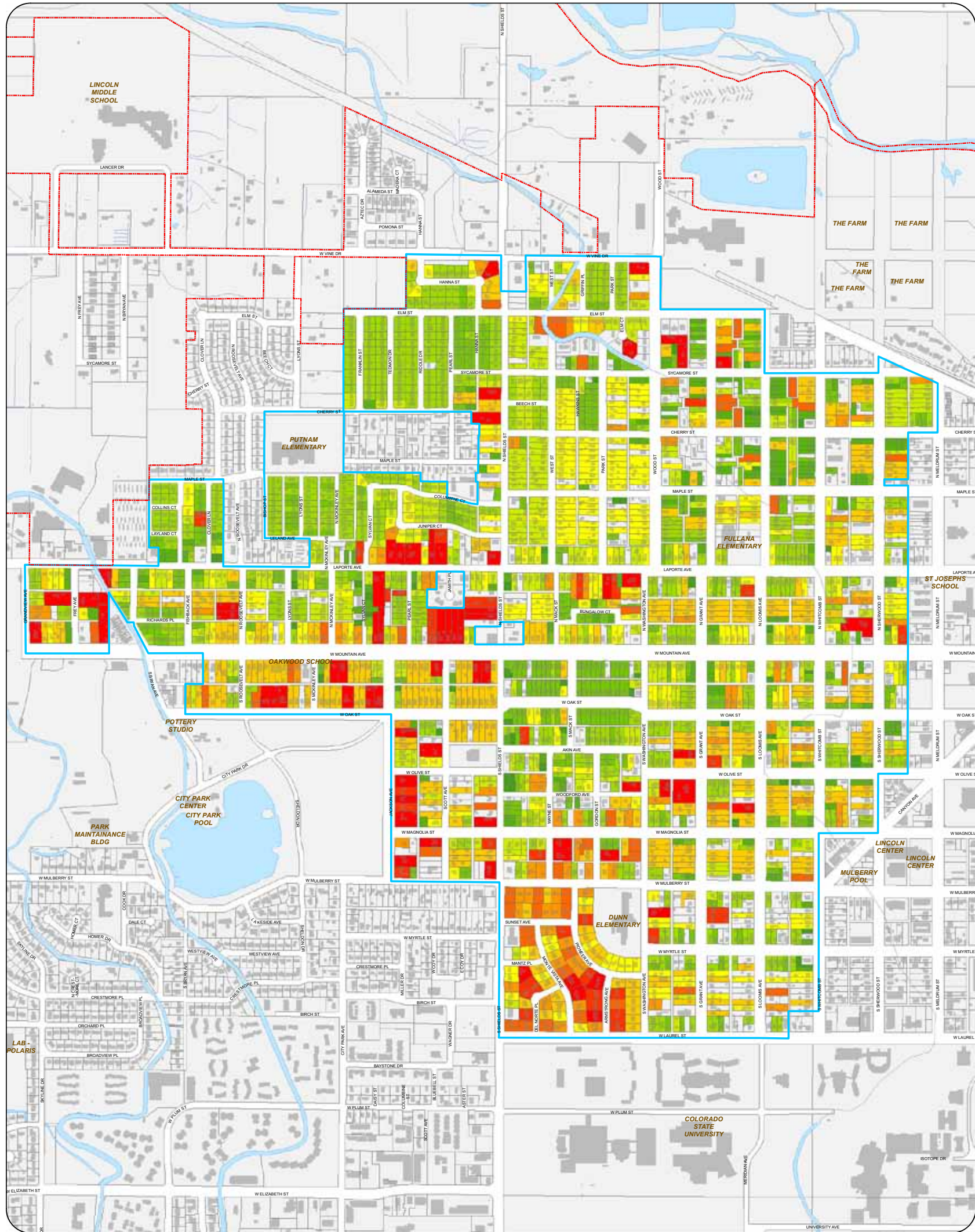

CITY OF FORT COLLINS
GEOGRAPHIC INFORMATION SYSTEM MAP PRODUCTS
 These map products and all underlying data are developed for use by the City of Fort Collins for its internal purposes only, and were not designed or intended for general use by members of the public. The City makes no representation or warranty as to its accuracy, timeliness, or completeness, and in particular, its accuracy in labeling or displaying dimensions, contours, property boundaries, or placement of location of any map features thereon. THE CITY OF FORT COLLINS MAKES NO WARRANTY OF MERCHANTABILITY OR FITNESS FOR USE FOR PARTICULAR PURPOSE, EXPRESSED OR IMPLIED, WITH RESPECT TO THESE MAP PRODUCTS OR THE UNDERLYING DATA. Any use of these map products, map applications, or data, except those AS IS, WITH ALL FAULTS, and assumes all responsibility of the user thereof, and further covenants and agrees to hold the City harmless from and against all damage, loss, or liability arising from any use of the map products, in consideration of the City's having made this information available. Independent verification of all data contained herein should be obtained by any users of these products or underlying data. The City disclaims, and shall not be held liable for any and all damage, loss, or liability, whether direct, indirect, or consequential, which arises or may arise from these map products or the use thereof by any person or entity.

	Buildings	Lot Size			
	Water Features	Square Feet			
	Parcels		Less than 4,000		7,000
	City Limits		4,000		10,000
	Westside Neighborhood		5,000		13,000 +



Printed: July 05, 2012

The Lot Size map shows patterns in square footage of lots throughout the neighborhood. In the Westside, most blocks have a predominant lot size, with the exception of curvilinear street patterns and smaller or subdivided corner lots. Areas with "H"-shaped alleys will also have a large range in lot sizes, typically with several larger lots along a block of smaller lots. More variety in lot size also occurs along W. Mountain Avenue, though several individual blocks remain consistent.

Westside Neighborhood: Lot Frontage

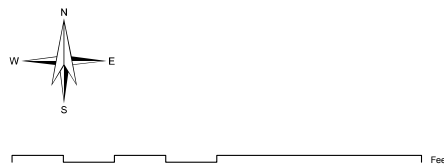
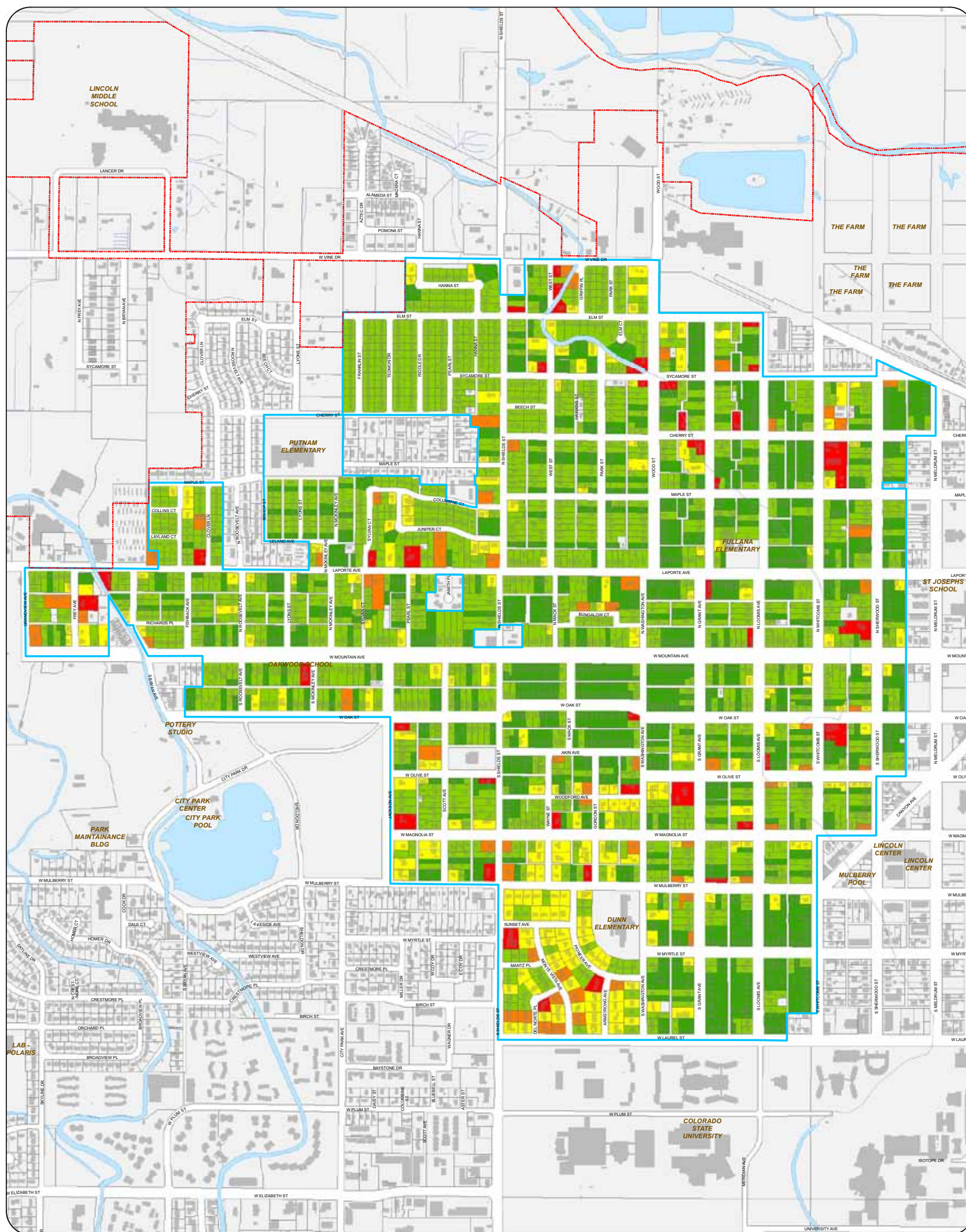

**CITY OF FORT COLLINS
GEOGRAPHIC INFORMATION SYSTEM MAP PRODUCTS**

These map products and all underlying data are developed for use by the City of Fort Collins for its internal purposes only, and were not designed or intended for general use by members of the public. The City makes no representation or warranty as to the accuracy, timeliness, or completeness, and in particular, its accuracy in labeling or depicting dimensions, contours, property boundaries, or placement of location of any map features herein. THE CITY OF FORT COLLINS MAKES NO WARRANTY OF MERCHANTABILITY OR FITNESS FOR FITNESS OF USE FOR PARTICULAR PURPOSE, EXPRESSED OR IMPLIED, WITH RESPECT TO THESE MAP PRODUCTS OR THE UNDERLYING DATA. Any uses of these map products, map applications, or data, except those AS IS, WITH ALL FAILS, and assumes all responsibility of the use thereof, and further covenants and agrees to hold the City harmless from and against all damage, loss, or liability arising from any use of the map product. In consideration of the City's having made this information available, independent verification of all data contained herein should be obtained by any users of these products, or underlying data. The City disclaims, and shall not be held liable for any and all damage, loss, or liability, whether direct, indirect, or consequential, which arises or may arise from these map products or the use thereof by any person or entity.

	Buildings		25 - 50
	Water Features		51 - 75
	Parcels		76 - 100
	City Limits		101 - 125
	Westside Neighborhood		More than 125



Printed: July 05, 2012

The Lot Frontage map shows patterns in width of lots throughout the neighborhood. Combined with lot size, the frontage helps determine if a lot may legally be subdivided. In the Westside, lot frontage is typically 75 feet or less, with some areas of slightly wider lots. Exceptions occur on corner lots, along curvilinear streets, and where "H"-shaped alleys occur. Several areas along W. Mountain Avenue also differ, having much narrower lot frontage than the neighborhood's average.

Westside Neighborhood: Lot Coverage

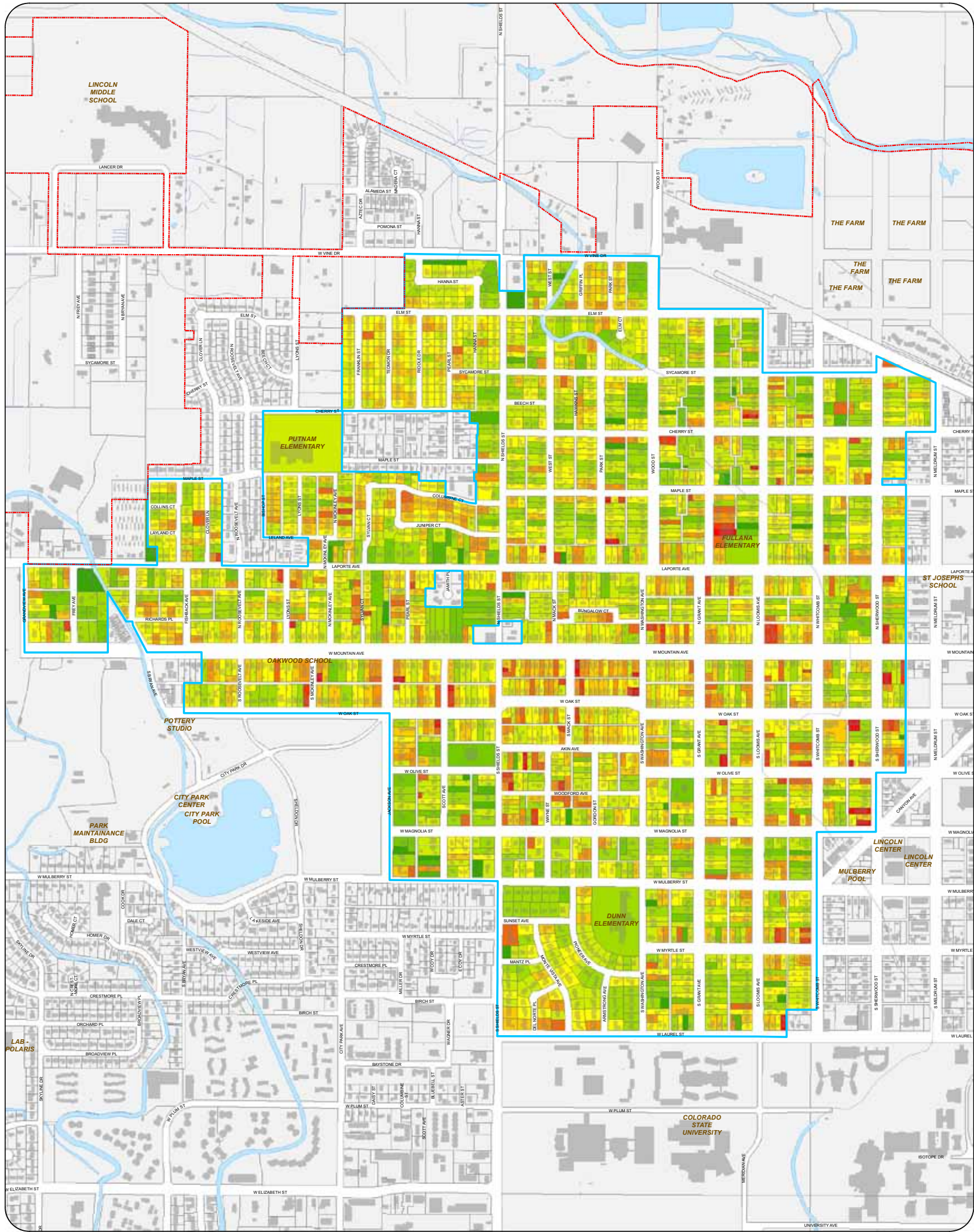

CITY OF FORT COLLINS
GEOGRAPHIC INFORMATION SYSTEM MAP PRODUCTS
These map products and all underlying data are developed for use by the City of Fort Collins for its internal purposes only, and were not designed or intended for general use by members of the public. The City makes no representation or warranty as to its accuracy, timeliness, or completeness, and in particular, its accuracy in labeling or displaying dimensions, contours, property boundaries, or placement of location of any map features thereon. THE CITY OF FORT COLLINS MAKES NO WARRANTY OF MERCHANTABILITY OR WARRANTY FOR FITNESS FOR PARTICULAR PURPOSE, EXPRESSED OR IMPLIED, WITH RESPECT TO THESE MAP PRODUCTS OR THE UNDERLYING DATA. Any users of these map products, map applications, or data, accept them AS IS, WITH ALL FAULTS, and assumes all responsibility of the use thereof, and further consents and agrees to hold the City harmless from and against all damage, loss, or liability arising from any use of the map product, in consideration of the City's having made this information available. Independent verification of all data contained herein should be obtained by any users of these products or underlying data. The City disclaims, and shall not be held liable for any and all damage, loss, or liability, whether direct, indirect, or consequential, which arises or may arise from these map products or the use thereof by any person or entity.

	Buildings	Lot Coverage Less than 5% 5% - 9% 10% - 14% 15% - 19% 20% - 24% 25% - 29% 30% - 34% 35% - 39% 40% - 44% 45% - 49% 50% +
	Water Features	
	Parcels	
	City Limits	
	Westside Neighborhood	



Printed: July 05, 2012

The Lot Coverage map shows patterns in percentage of covered lot throughout the neighborhood. Lot coverage typically varies throughout each block in the Westside. Most lots are less than 50% covered. Blocks along W. Mountain Avenue have a higher average lot coverage than is typical of the rest of the neighborhood.

Appendix B: Character Area Maps

See Part 1: Neighborhood Profile for full descriptions of the Character Areas.

Eastside and Westside Neighborhoods Character Study Draft Character Areas - Eastside Neighborhood

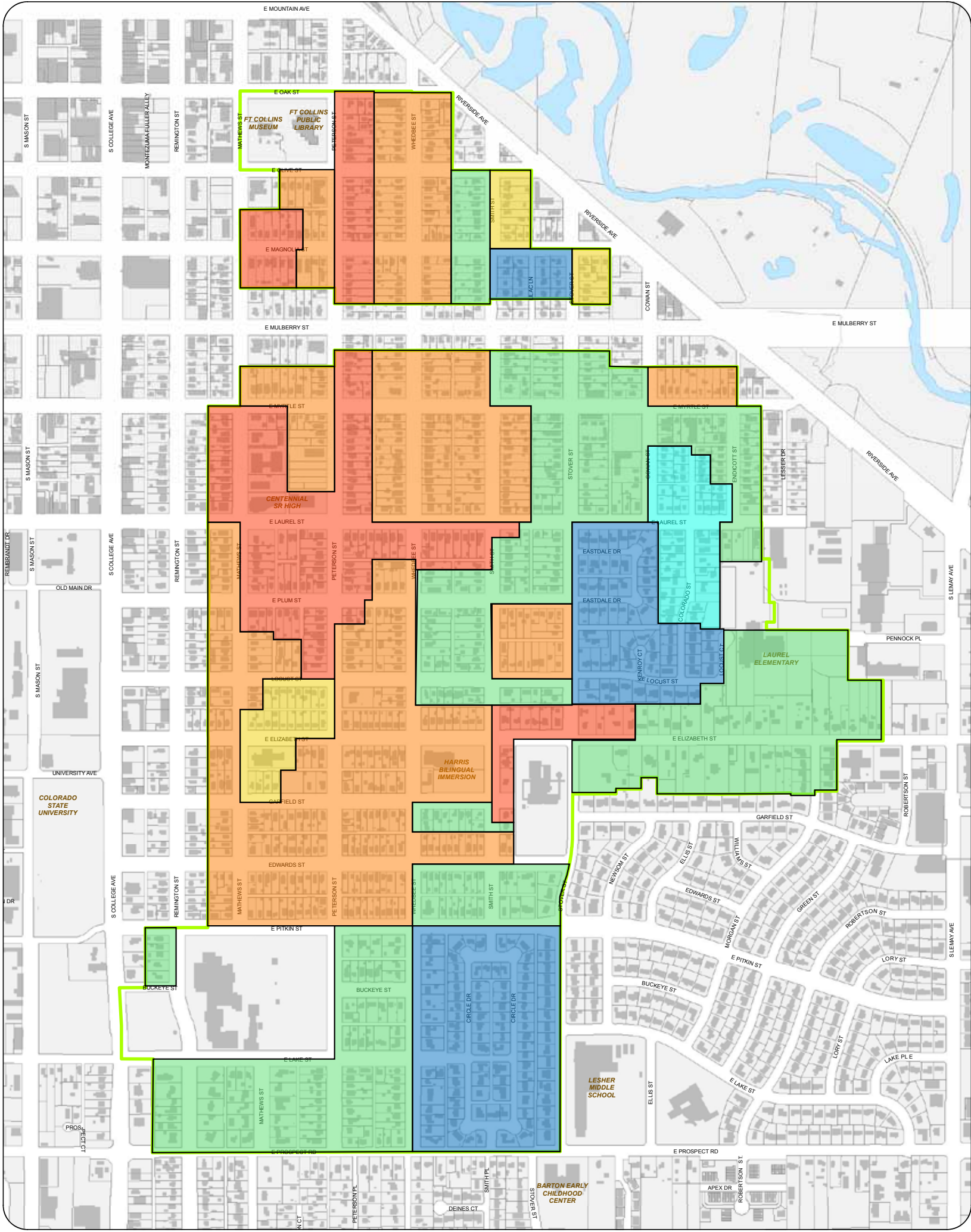

0 250 500 1,000 Feet

**CITY OF FORT COLLINS
GEOGRAPHIC INFORMATION SYSTEM MAP PRODUCTS**
These map products and all underlying data are developed for use by the City of Fort Collins for its internal purposes only, and were not designed or intended for general use by members of the public. The City makes no representation or warranty as to its accuracy, timeliness, or completeness, and in particular, its accuracy in labeling or displaying dimensions, contours, property boundaries, or placement of location of any map features herein. THE CITY OF FORT COLLINS MAKES NO WARRANTY OF MERCHANTABILITY OR FITNESS FOR USE FOR PARTICULAR PURPOSE, EXPRESSED OR IMPLIED, WITH RESPECT TO THESE MAP PRODUCTS OR THE UNDERLYING DATA. Any users of these map products, map applications, or data, accept them AS IS, WITH ALL FAULTS, and assumes all responsibility of the use thereof, and further covenants and agrees to hold the City harmless from and against all damage, loss, or liability arising from any use of this map product, in consideration of the City's having made this information available. Independent verification of all data contained herein should be obtained by any users of these products, or underlying data. The City disclaims, and shall not be held liable for any and all damage, loss, or liability, whether direct, indirect, or consequential, which arises or may arise from these map products or the use thereof by any person or entity.

- Character Area 1
- Character Area 2
- Character Area 3
- Character Area 4
- Character Area 5
- Character Area 6



Printed: October 01, 2012

Eastside and Westside Neighborhoods Character Study

Draft Character Areas - Westside Neighborhood

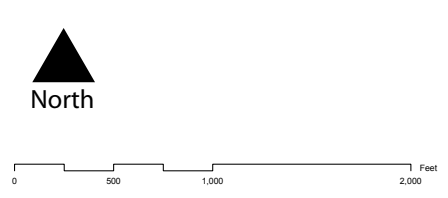
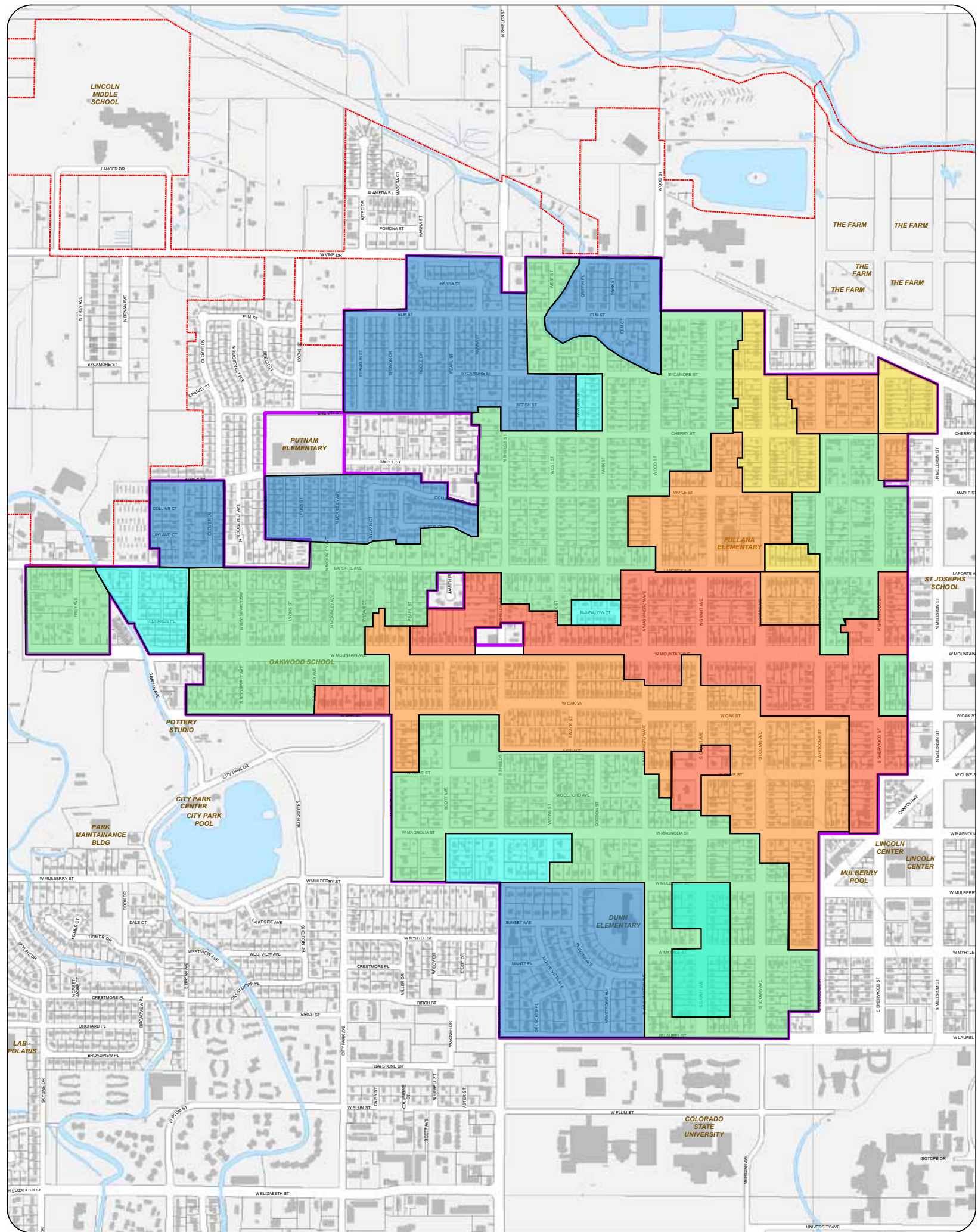

CITY OF FORT COLLINS
GEOGRAPHIC INFORMATION SYSTEM MAP PRODUCTS
 These map products and all underlying data are developed for use by the City of Fort Collins for its internal purposes only, and were not designed or intended for general use by members of the public. The City makes no representation or warranty as to the accuracy, timeliness, or completeness, or in particular, its accuracy in labeling or displaying dimensions, contours, property boundaries, or placement of location of any map features hereon. THE CITY OF FORT COLLINS MAKES NO WARRANTY OF MERCHANTABILITY OR WARRANTY FOR FITNESS FOR USE FOR PARTICULAR PURPOSES, EXPRESSED OR IMPLIED, WITH RESPECT TO THESE MAP PRODUCTS OR THE UNDERLYING DATA. Any users of these map products, map applications, or data, access them AS IS, WITH ALL FAULTS, and assumes all responsibility of the use thereof, and further covenants and agrees to hold the City harmless from and against all damages, loss, or liability arising from any use of this map product. If consideration of the City's having made this information available. Independent verification of all data contained herein should be obtained by any users of these products, or underlying data. The City disclaims, and shall not be held liable for any and all damages, loss, or liability, whether direct, indirect, or consequential, which arises or may arise from these map products or the use thereof by any person or entity.

- Character Area 1
- Character Area 2
- Character Area 3
- Character Area 4
- Character Area 5
- Character Area 6



Printed: October 01, 2012

Appendix C: Building Permits

GIS data was collected to visually portray building permits granted since 1997. See Part 1: Neighborhood Profile for further information.

Eastside and Westside Neighborhoods Character Study Eastside Building Permits: 1997-2012 (YTD)

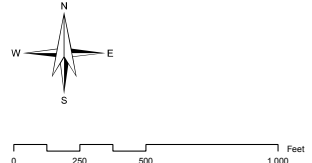
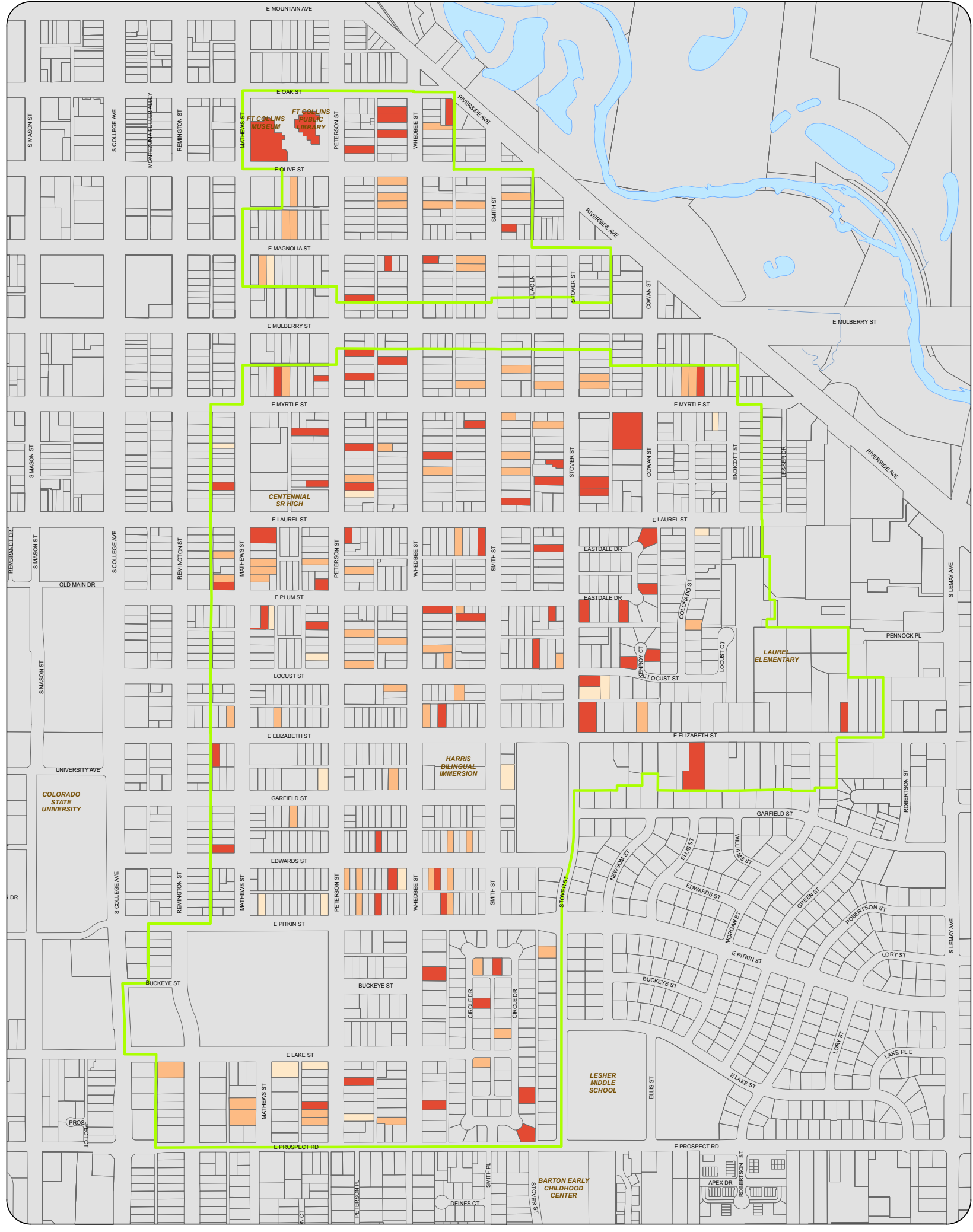

**CITY OF FORT COLLINS
GEOGRAPHIC INFORMATION SYSTEM MAP PRODUCTS**

These map products and all underlying data are developed for use by the City of Fort Collins for its internal purposes only, and were not designed or intended for general use by members of the public. The City makes no representation or warranty as to its accuracy, timeliness, or completeness, and in particular, its accuracy in labeling or displaying dimensions, contours, property boundaries, or placement of location of any map features shown. THE CITY OF FORT COLLINS MAKES NO WARRANTY OF MERCHANTABILITY OR FITNESS FOR USE FOR PARTICULAR PURPOSES, EXPRESS OR IMPLIED, WITH RESPECT TO THESE MAP PRODUCTS OR THE UNDERLYING DATA. Any users of these map products, map applications, or data, accept them AS IS, WITH ALL FAULTS, and assume all responsibility of the use thereof, and further covenants and agrees to hold the City harmless from any and all claims, loss, or liability arising from any use of the map product. In consideration of the City's having made this information available, independent verification of all data contained herein should be obtained by any users of these products, or underlying data. The City disclaims, and shall not be held liable for any and all damage, loss, or liability, whether direct, indirect, or consequential, which arises or may arise from these map products or the use thereof by any person or entity.

Building Permits	
Year	
	1997 - 2001
	2002 - 2006
	2007 - 2012 (YTD)

	Water Features
	Parcels
	City Limits
	Eastside Neighborhood



Printed: October 30, 2012

GIS data on building permits granted since 1997 show recent increases in construction activity in the Eastside and Westside Neighborhoods. A lesser percentage of this activity is concentrated in the Eastside Neighborhood.

Eastside and Westside Neighborhoods Character Study

Westside Building Permits: 1997-2012 (YTD)

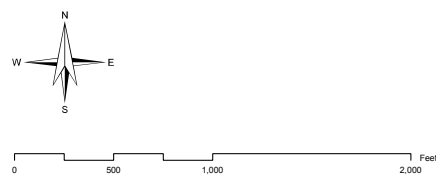
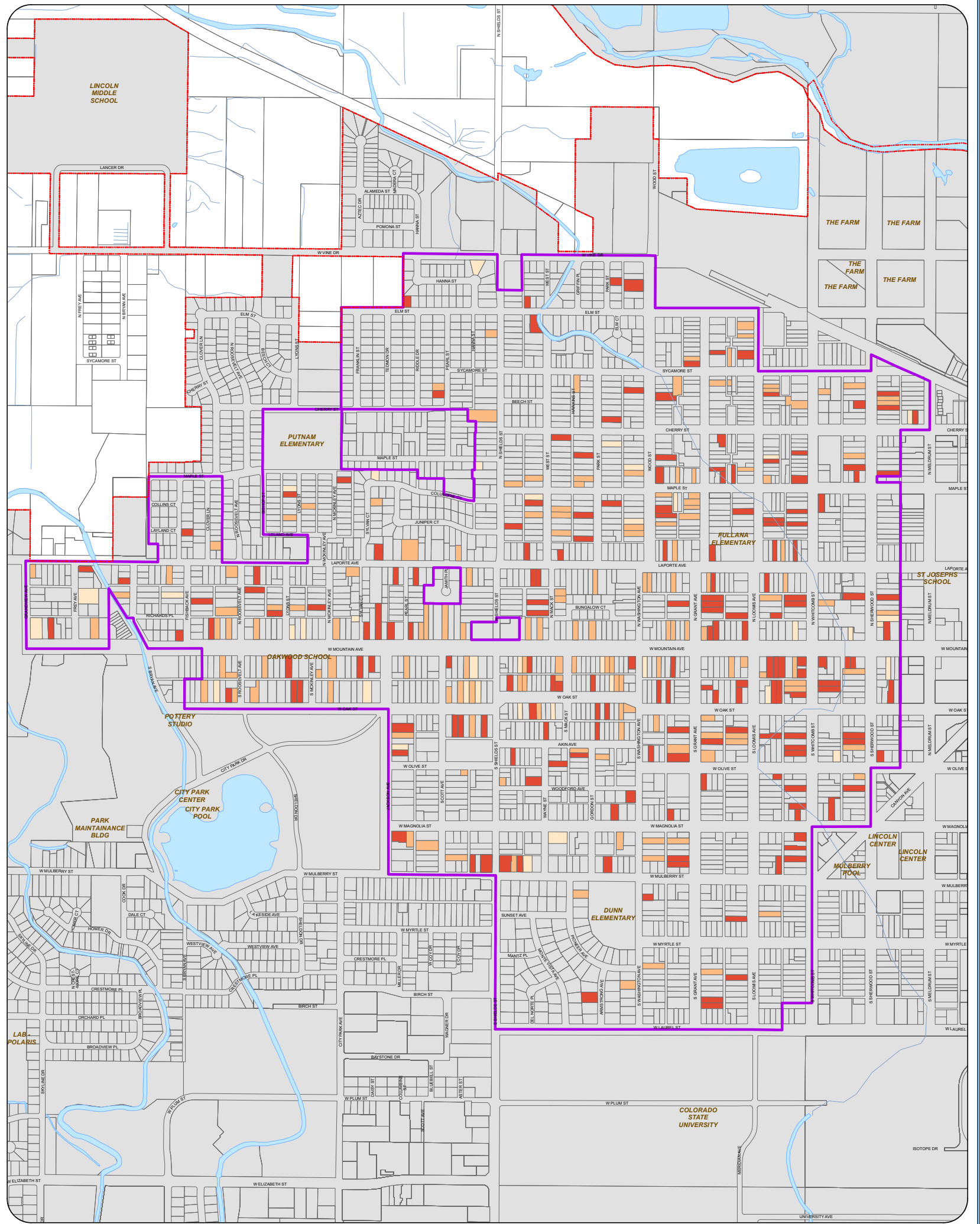

**CITY OF FORT COLLINS
GEOGRAPHIC INFORMATION SYSTEM MAP PRODUCTS**

These map products and all underlying data are developed for use by the City of Fort Collins for its internal purposes only and were not designed or intended for general use by members of the public. The City makes no representation or warranty as to the accuracy, timeliness, or completeness, and in particular, its accuracy in labeling or displaying dimensions, contours, property boundaries, or placement of location of any map features hereon. THE CITY OF FORT COLLINS MAKES NO WARRANTY OF MERCHANTABILITY OR WARRANTY FOR FITNESS OF USE FOR PARTICULAR PURPOSE, EXPRESSED OR IMPLIED, WITH RESPECT TO THESE MAP PRODUCTS OR THE UNDERLYING DATA. Any users of these map products, map applications, or data, accepts their use IS WITH ALL FAULTS, and assumes all responsibility of the use thereof, and further covenants and agrees to hold the City harmless from and against all damages, loss, or liability arising from any use of this map product. In consideration of the City having made this information available, independent verification of all data contained herein should be obtained by any users of these products, or underlying data. The City disclaims, and shall not be held liable for any and all damages, loss, or liability, whether direct, indirect, or consequential, which arises or may arise from these map products or the use thereof by any person or entity.

Building Permits	
Year	
	1997 - 2001
	2002 - 2006
	2007 - 2012 (YTD)

	Water Features
	Parcels
	City Limits
	Westside Neighborhood



Printed: October 30, 2012

GIS data on building permits granted since 1997 show recent increases in construction activity in the Eastside and Westside Neighborhoods. A greater percentage of this activity is concentrated in the Westside Neighborhood.

Appendix D: Variances

GIS data was collected to visually portray variances granted since 1997. See Part 1: Neighborhood Profile for further information.

Eastside and Westside Neighborhoods Character Study Eastside Variances: 1997-2012 (YTD)

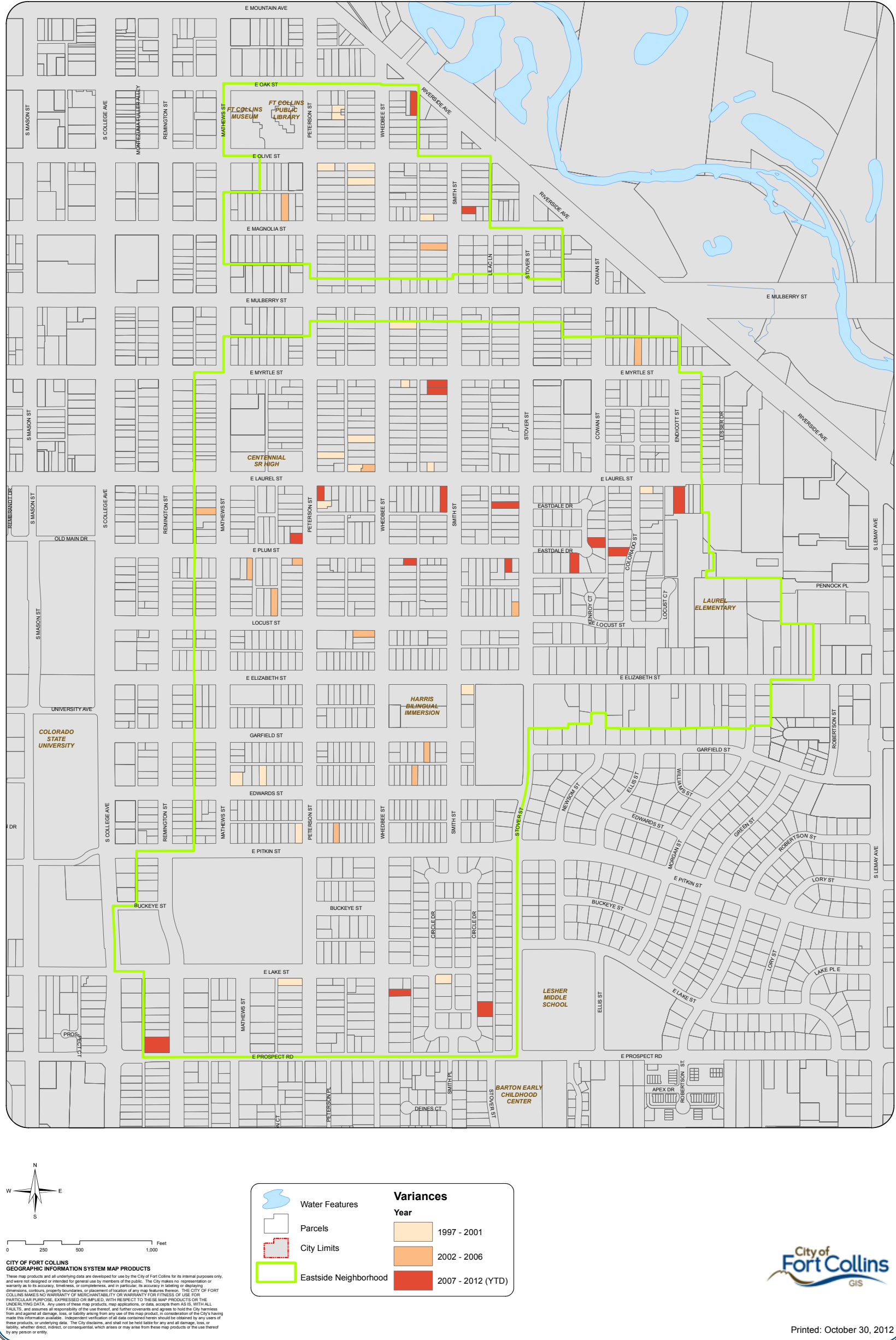

On average, the number of variances granted within the Eastside and Westside Neighborhoods has remained steady since 1997, with a lesser percentage being located in the Eastside Neighborhood.

Appendix D: Variances xxiii

Eastside and Westside Neighborhoods Character Study

Westside Variances: 1997-2012 (YTD)

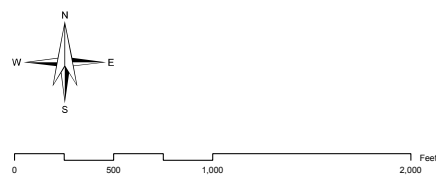
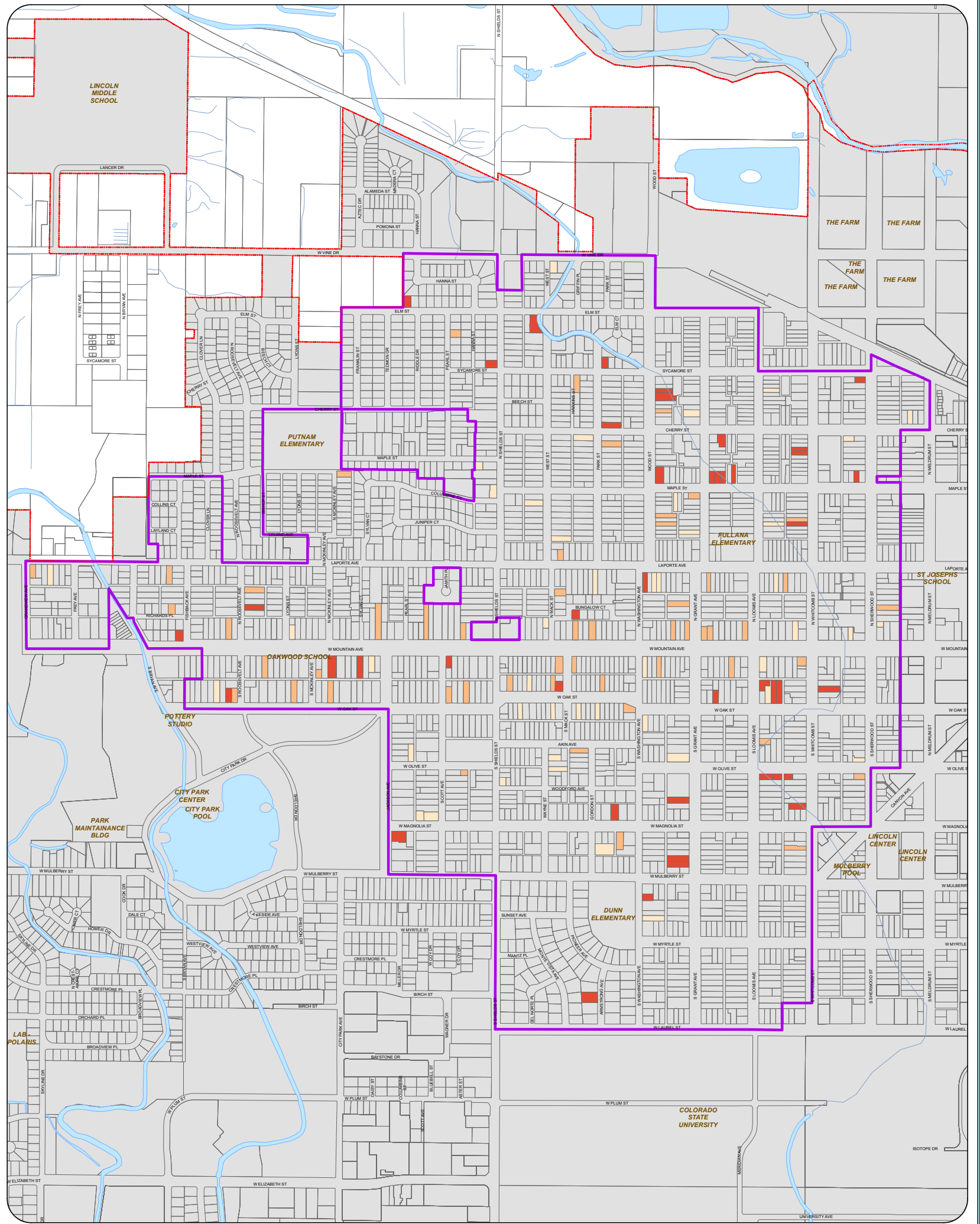

CITY OF FORT COLLINS
GEOGRAPHIC INFORMATION SYSTEM MAP PRODUCTS
 These map products and all underlying data are developed for use by the City of Fort Collins for its internal purposes only and were not designed or intended for general use by members of the public. The City makes no representation or warranty as to the accuracy, timeliness, or completeness, and in particular, its accuracy in labeling or displaying dimensions, contours, property boundaries, or placement of location of any map features hereon. THE CITY OF FORT COLLINS MAKES NO WARRANTY OF MERCHANTABILITY OR WARRANTY FOR FITNESS OF USE FOR PARTICULAR PURPOSE, EXPRESSED OR IMPLIED, WITH RESPECT TO THESE MAP PRODUCTS OR THE UNDERLYING DATA. Any users of these map products, map applications, or data, accepts their use IS WITH ALL FAULTS, and assumes all responsibility of the use thereof, and further covenants and agrees to hold the City harmless from and against all damages, loss, or liability arising from any use of this map product. In consideration of the City's having made this information available, independent verification of all data contained herein should be obtained by any users of these products, or underlying data. The City disclaims, and shall not be held liable for any and all damages, loss, or liability, whether direct, indirect, or consequential, which arises or may arise from these map products or the use thereof by any person or entity.

Variances	
Year	
	1997 - 2001
	2002 - 2006
	2007 - 2012 (YTD)



Printed: October 30, 2012

On average, the number of variances granted within the Eastside and Westside Neighborhoods has remained steady since 1997, with a greater percentage being located in the Westside Neighborhood.