



Historic Preservation Services

Community Development & Neighborhood Services

281 North College Avenue
P.O. Box 580
Fort Collins, CO 80522.0580

970.416.4250

preservation@fcgov.com

fcgov.com/historicpreservation

CERTIFICATE OF APPROPRIATENESS – Minor Alteration

ISSUED: May 11, 2021

EXPIRATION: May 11, 2022

Thomas Linenberger
5 Old Town Square, Suite 216
Fort Collins, CO 80524

Dear Property Owner:

This letter provides you with certification that proposed work to your property at 23 Old Town Square, a non-contributing building in the Old Town Landmark District, has been approved by the City's Historic Preservation Division (HPD) because the proposed work appears to meet the requirements of Chapter 14, [Article IV](#) of the Fort Collins Municipal Code, and the Old Town Design Standards as adopted.

The alterations reviewed include:

- New stand-alone metal awning with a fabric cover.
 - *Note: 23 Old Town Square is a non-contributing building constructed in 1981. The new awning is not expected to have a detrimental effect on the Landmark District as a whole.*

Notice of the approved application has been provided to building and zoning staff to facilitate the processing of any permits that are needed for the work.

Please note that work beyond that indicated in your permit application/correspondence requires additional approval.

If the approved work is not completed prior to the expiration date noted above, you may apply for an extension by contacting staff at least 30 days prior to expiration. Extensions may be granted for up to 12 additional months, based on a satisfactory staff review of the extension request.

If you have any questions regarding this approval, or if I may be of any assistance, please do not hesitate to contact me. I may be reached at jbertolini@fcgov.com or 970-416-4250.

Sincerely,

Jim Bertolini
Historic Preservation Planner

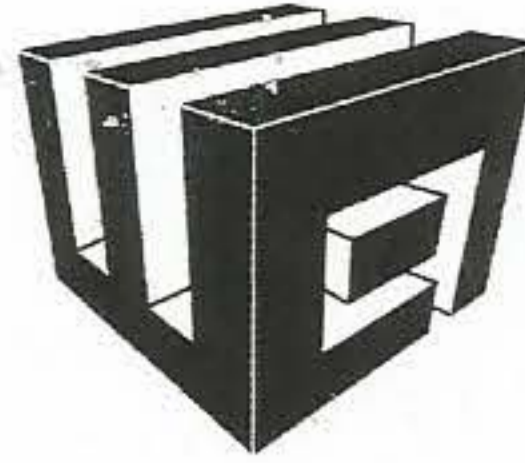

WEEKS
& ASSOCIATES
STRUCTURAL ENGINEERS

March 17, 2021

Gilsdorf Canvas & Awning, Inc.
410 Summit View
Fort Collins, CO 80524

**Re: Goldworks - Entry Canopy
#23 Old Town Square
Fort Collins, CO**

As requested I have provided a structural review of the free-standing entryh canopy to be installed at the referenced site.

BACKGROUND

The canopy is 10' by 7' in plan and 8' tall with a curved fabric covered roof. The construction is steel tube as noted on the drawings by Gilsdorf and the canopy is supported on steel columns embedded into concrete piers as noted on the drawings.

Design live loads used in my review are 140 mph Vult, exposure B wind, 20 psf live load and 30 psf snow load.

OPINION

Based on my review it is my opinion the proposed construction is adequate for the design loads. A sketch of the proposed canopy by Gilsdorf Canvas & Awning is attached.

If I can be of further assistance please contact me.

Sincerely,
Weeks & Associates, Inc.

Gary G. Weeks, P.E.
Structural Engineer



Goldworks Freestanding Entry Canopy

#23 Old Town square

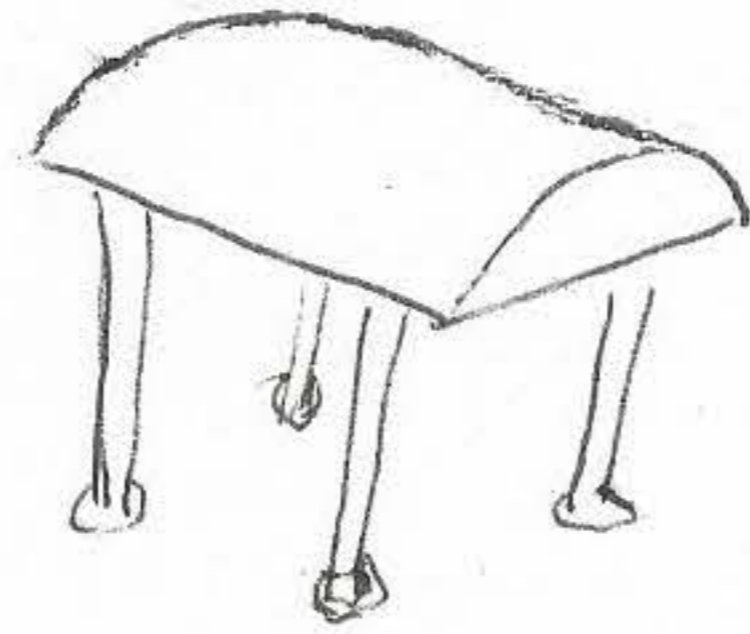
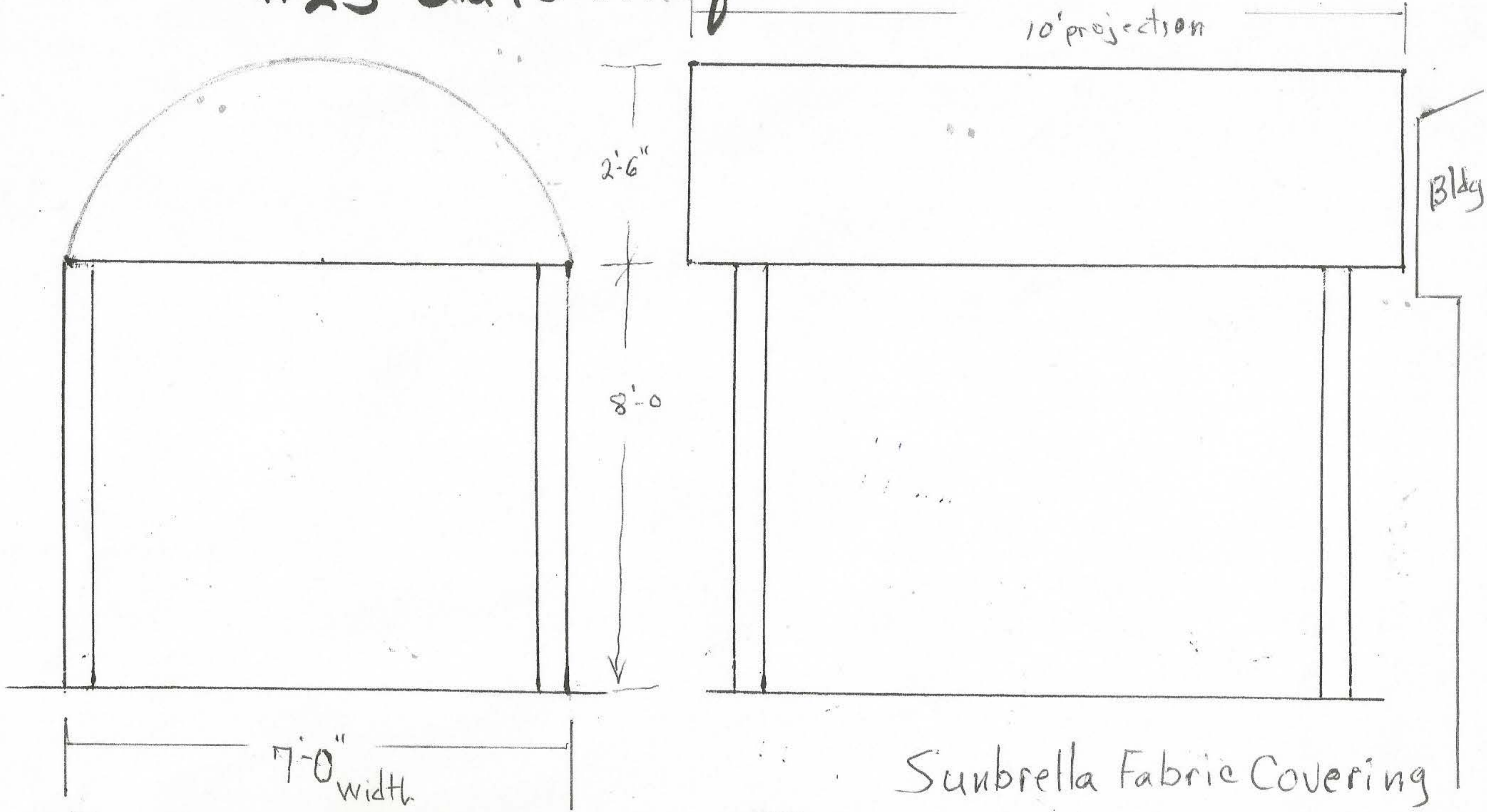

GILSDORF CANVAS & AWNING, INC
1816 Heath Parkway A
Fort Collins, CO 80524
224-2042
217-7880

Goldworks

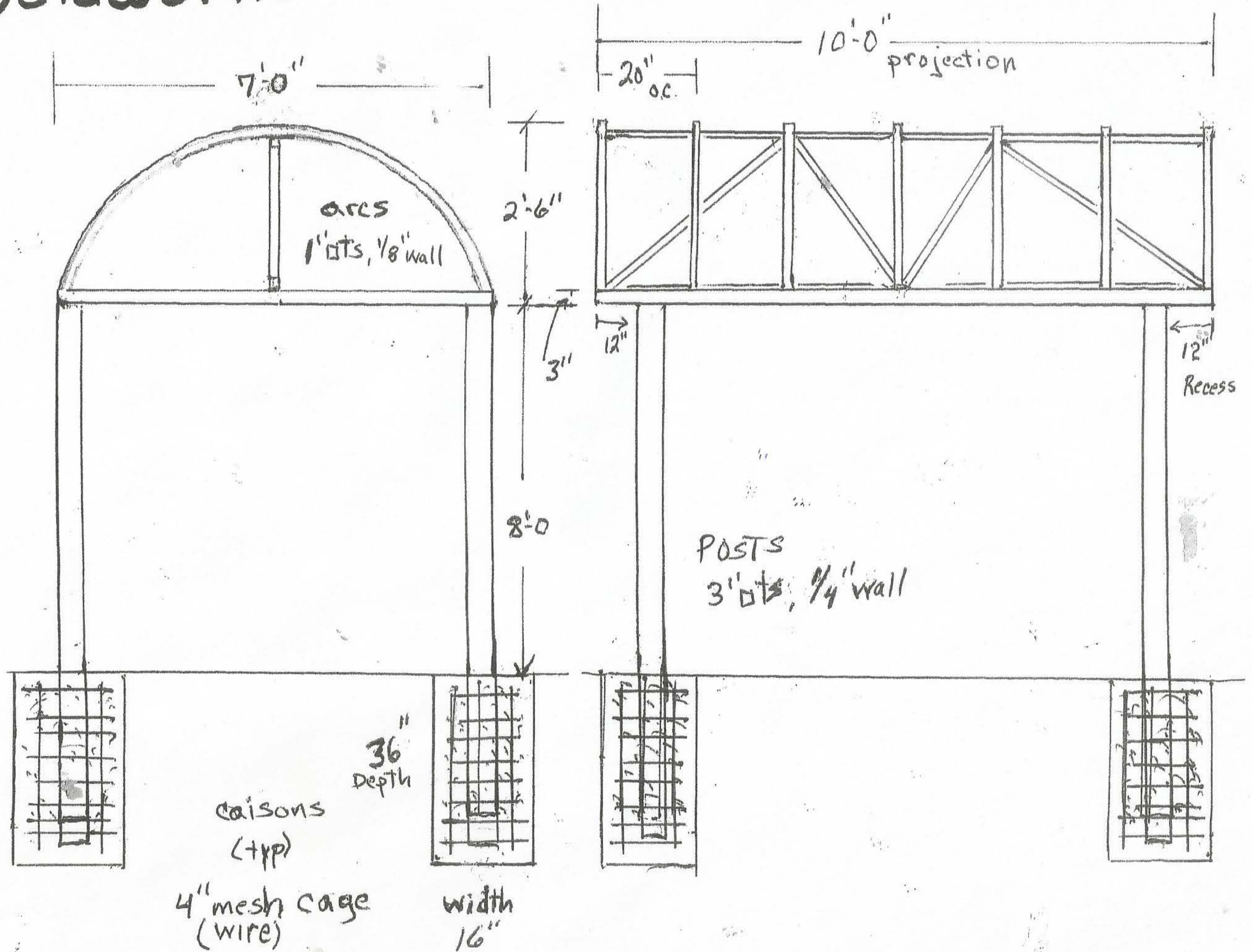

Goldworks

$\frac{1}{8}$ " wall, 1" o/s

Truss

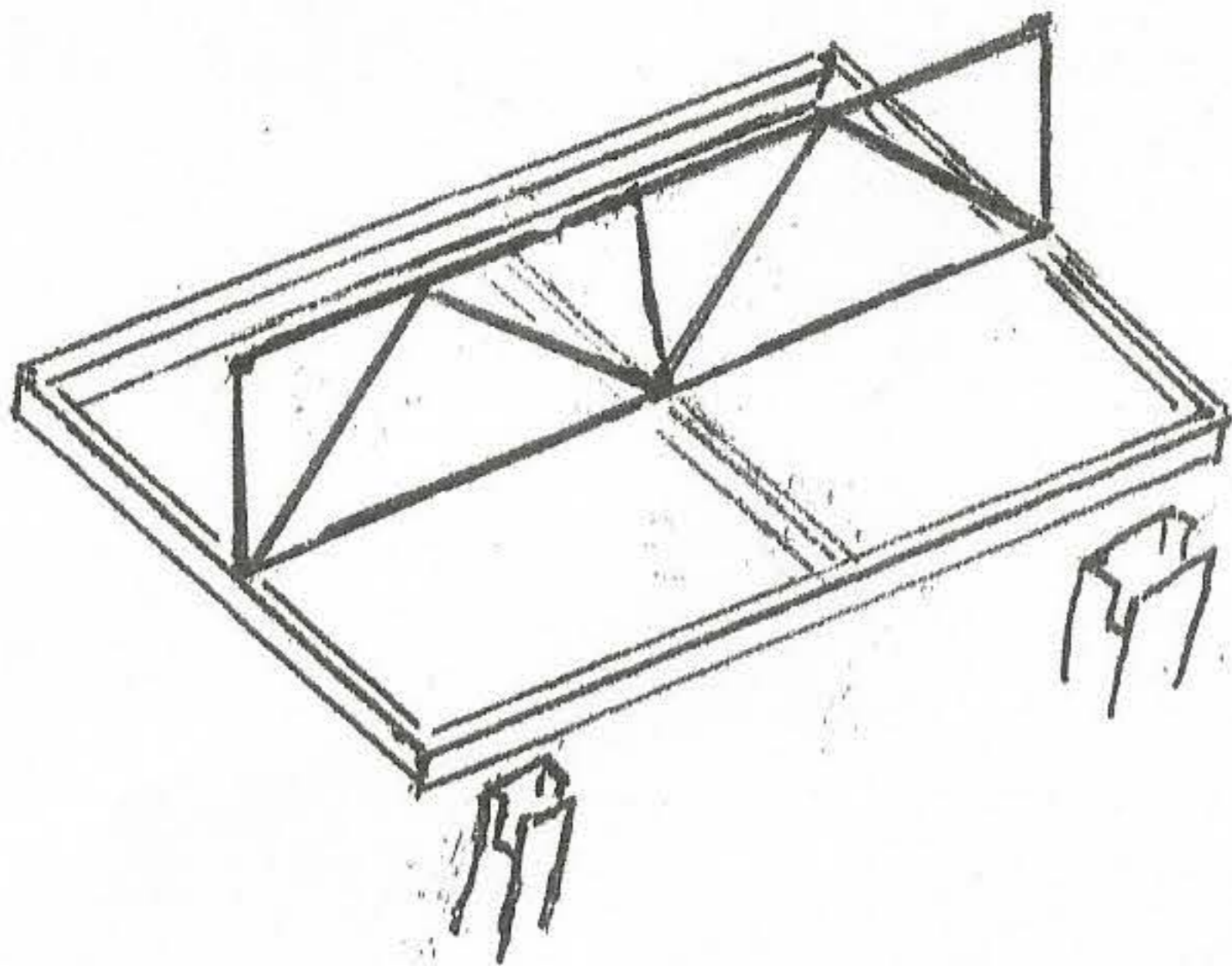
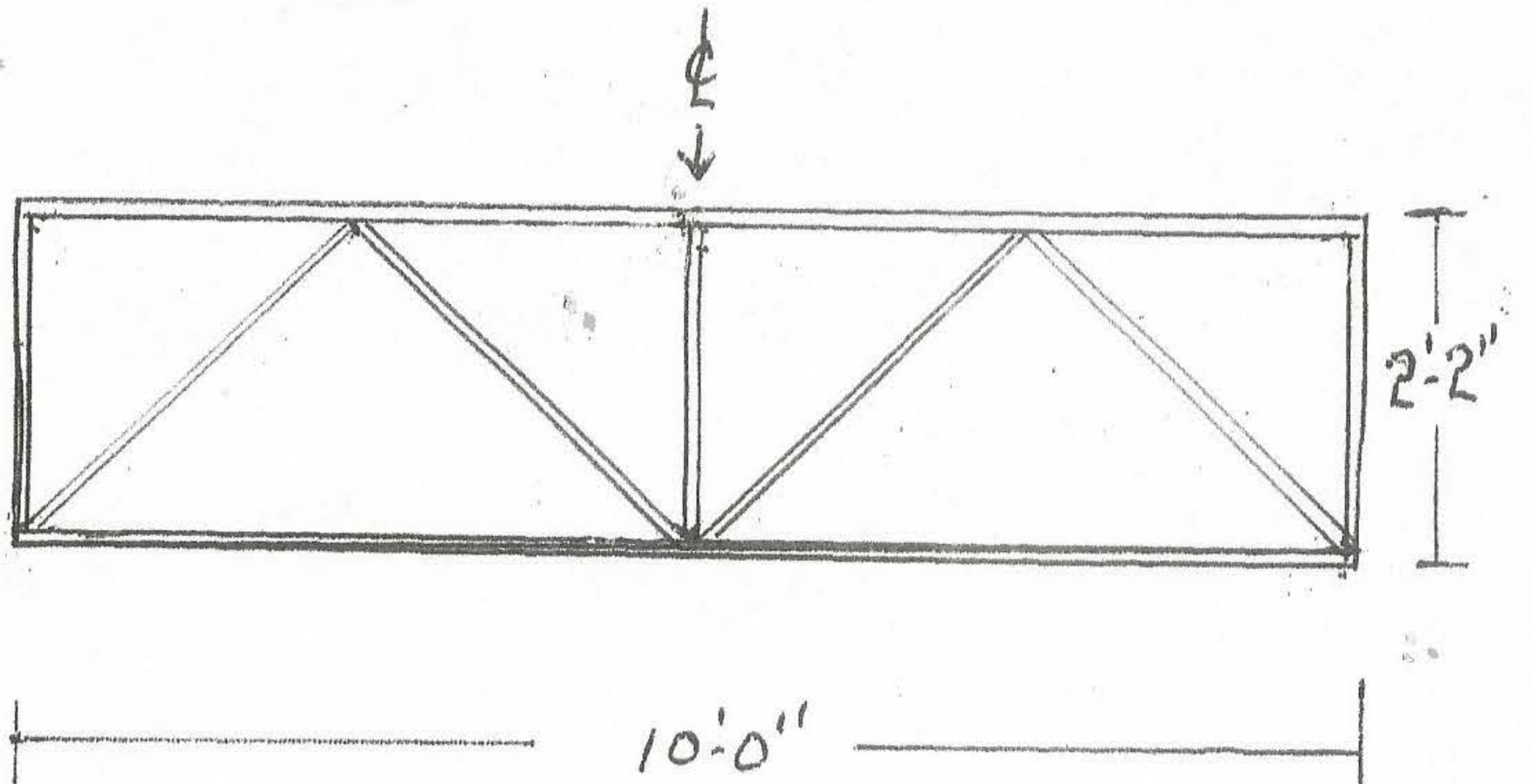

Base

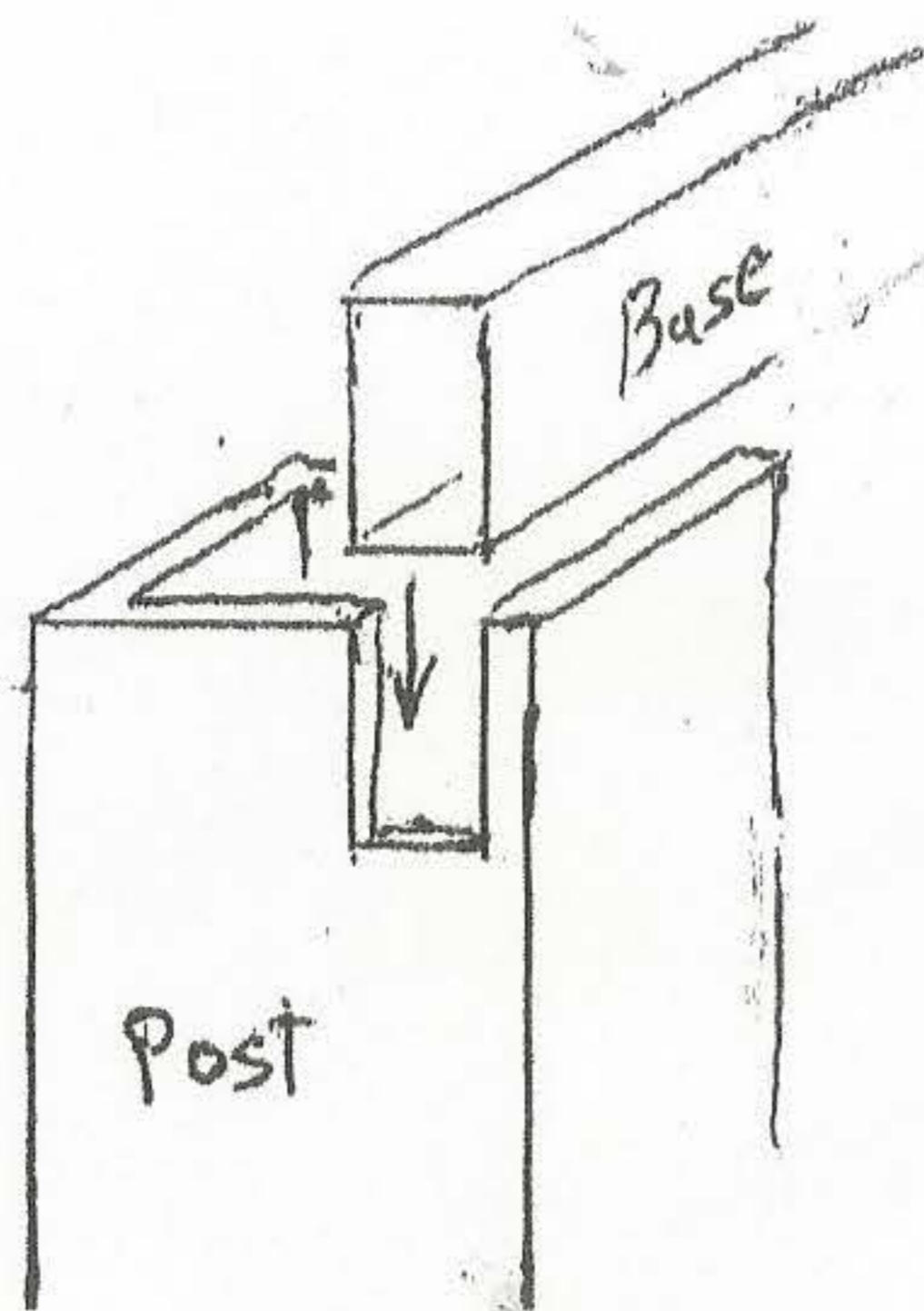
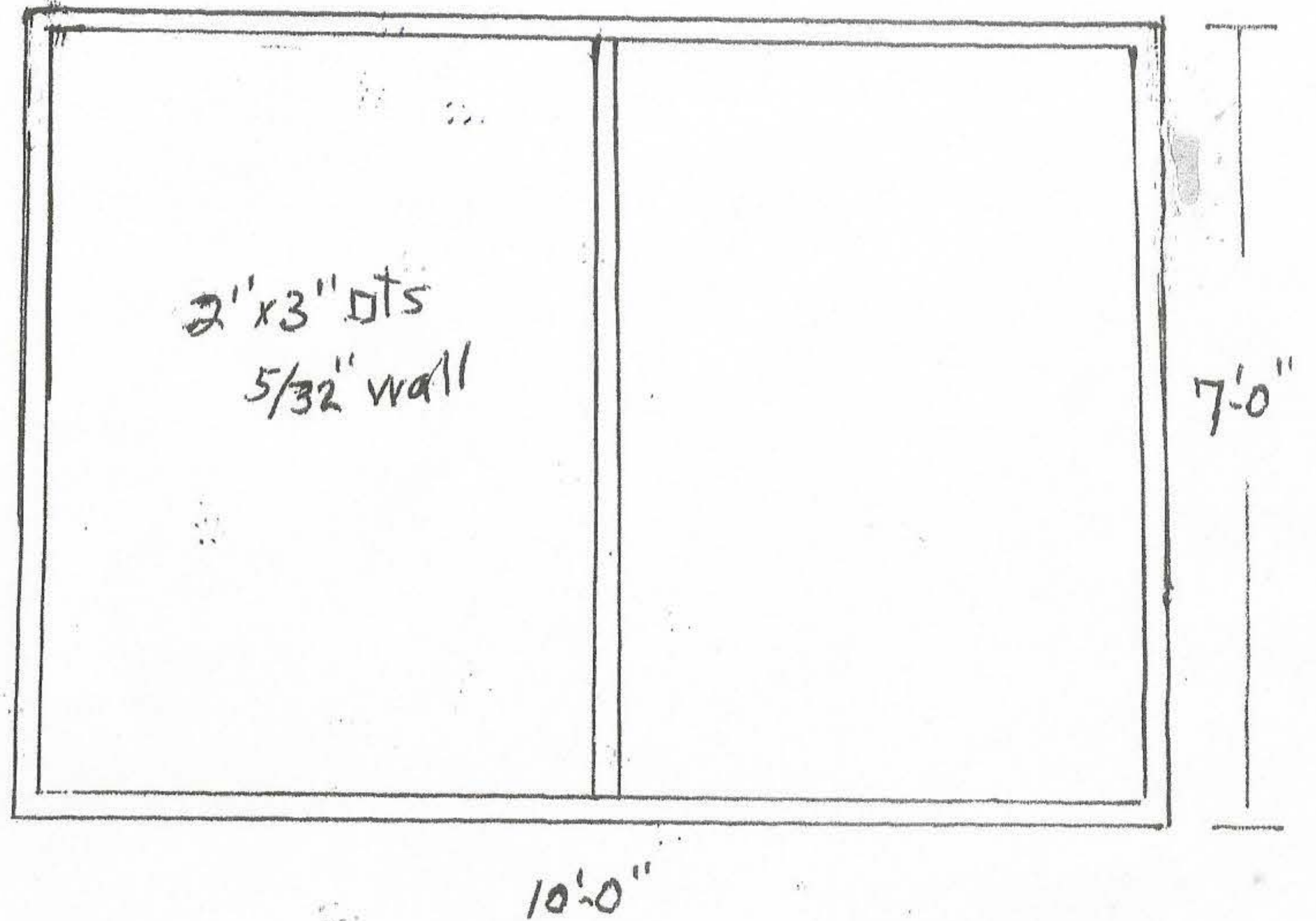

23 Old Town Sq.

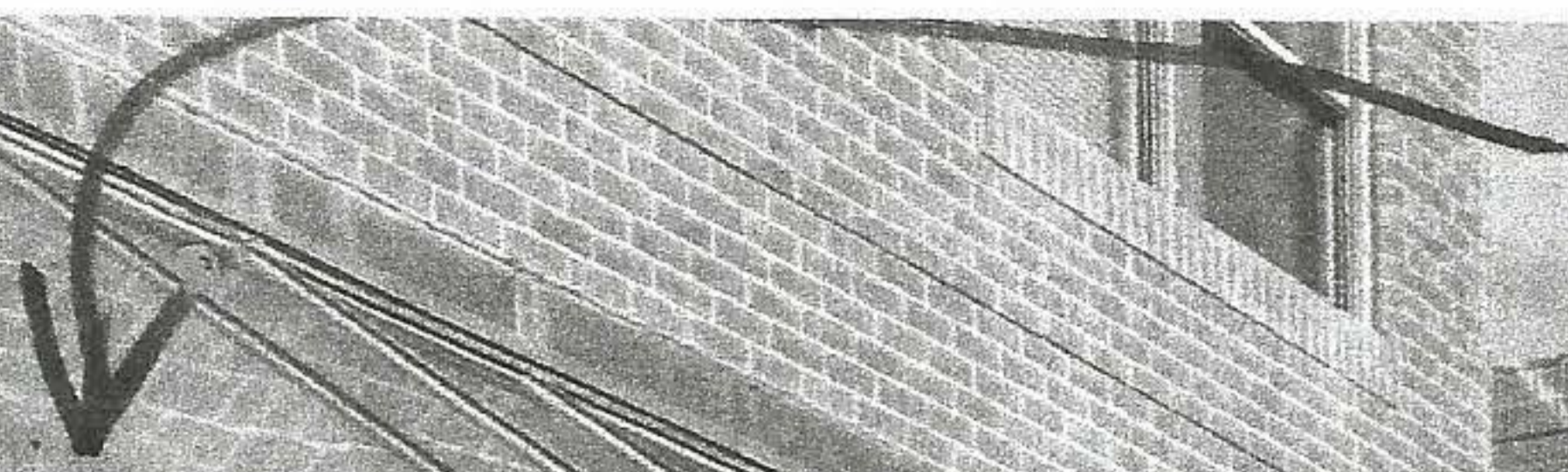

BAR & GRILL

10'

posts