

MAKING SOLAR ENERGY COST-EFFECTIVE TODAY IS A SNAP

Dr. James A. White, P.E.
Senior Energy Services Engineer
Chelan County Public Utility District
P.O. Box 1231
Wenatchee, Washington 98807
jamesa@chelanpud.org

ABSTRACT

An electric utility in Washington state has come up with a simple way to make solar energy cost-effective, without raising rates, in an area with some of the cheapest power in the nation. This paper explains how the award-winning SNAP (Sustainable Natural Alternative Power) program works.

Instead of expensive and heavily bureaucratic give-away rebate programs, SNAP relies on free-market supply and demand principles to make solar-generated energy cost-effective. SNAP has proven successful at getting a relatively large amount of solar power systems installed at the least possible cost.

The performance-based approach taken by Chelan County Public Utility District (PUD) is similar to Germany's very successful "feed-in tariff" program. SNAP differs from the German program in that it uses market forces to determine the price of solar power instead of prices set by the government or electric utility. This market rate for solar energy is determined by simply dividing the total annual dollars in the SNAP fund by the total number of solar kilowatt hours generated that year.

At Chelan County PUD, funds for the SNAP program come from voluntary monthly donations by customers. A SNAP fund could also be created by a federal, state, city, or local government designating a small percentage of utility revenue to promote the development of locally produced, customer-owned solar power generation.

1. INTRODUCTION

SNAP stands for Sustainable Natural Alternative Power. It is an innovative way to make solar power cost-effective today.

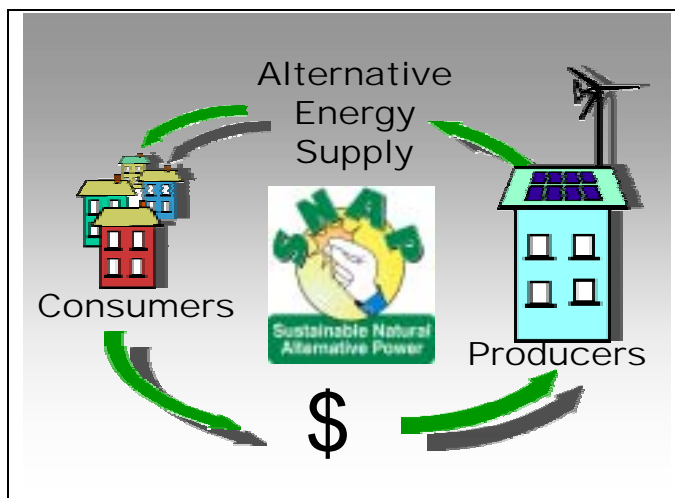

Fig. 1: SNAP Creates a Local Market for Solar Energy

$$\text{SNAP } \$/\text{kWh} = \frac{\text{Total Annual SNAP Dollars}}{\text{Total Annual Solar kWh}}$$

Creating a local solar power program is a SNAP:

- Step 1 - Create an annual fund designated for the development of locally produced solar power.
- Step 2 - Measure the amount of locally produced solar energy produced each year.
- Step 3 - Once a year, send power production checks to each solar producer.

Another way to describe the SNAP program is if a solar power producer generates 10% of the total solar energy in one year, he or she gets 10% of that year's SNAP fund. Chelan County PUD set a payment limit of \$1.50 per kWh to prevent all of the money from going to just a few producers early on in the program. If the \$1.50 per kWh limit is reached, funds remaining in the program are rolled over into the next year's fund.

With standard net-metered programs, the electric utility only credits kWh production against consumption and never writes you a check. Under SNAP, the utility always writes a check for the power produced. The size of the check depends on the amount of money in the SNAP fund and number of kilowatt hours generated by solar power that year. In addition to the SNAP funds, the PUD pays solar power producers the wholesale or credits their retail account for the power they produce.

2. CREATING A SNAP FUND

In Chelan County of Washington state, the demand for local green power is determined by the amount of voluntary contributions made by customers to the SNAP program. While Chelan PUD's program relies on voluntary contributions, this same performance-based program could also be applied to other funding sources. Another way to create a SNAP fund would be to designate a small fixed percentage of the utility bill toward the development of locally generated solar power.

2.1 Voluntary Contributions

Electric utility customers at Chelan County PUD can choose to donate a small amount each month to the SNAP program. The suggested contribution per residential customer ranges from \$2.50 to \$7.50 per month. Commercial customers can choose to designate \$10 to \$50 per month. Although these contribution levels are not tied to a specific number of kilowatt hours, the utility guarantees that 100% of these funds will go to local solar and small wind energy producers. Even though only 2 percent of Chelan PUD customers participate, the program generates about \$25,000 per year in customer contributions. Since starting the program two and half years ago, these contributions have resulted in over \$700,000 worth of new renewable power generation in Chelan County.

The advantage of using voluntary contributions:

- Does not raise electric rates
- Only impacts those customers who want to participate in the program.

The disadvantages of voluntary contributions:

- Additional marketing expenses
- Producers incur greater financial risks because the fund amount is uncertain.
- Increased administrative expenses to set up the billing system to accept voluntary contributions.

2.2 Utility Tax

While Chelan PUD's program relies on voluntary contributions, this same performance-based program could also be applied to other funding sources. Many cities and states already impose taxes on utility revenues collected in their area. An environmentally minded community or state could vote to increase or reallocate a small portion of the existing utility tax to pay local solar power producers for the power they produce.

The solar tax does not have to be very big to produce big results. Washington state recently considered legislation that would have created a \$3.5 million per year statewide solar fund by designating only 1.75 % of the existing state 3.5% utility tax (approximately 0.06% of the total utility revenue). Had the legislation passed, it would have created between 20 to 100 MW of new solar power generation over the next 10 years. Sales tax revenue generated by the new solar power installations would have funded the first few years of the 10 year program.

Advantages of a program relying on utility tax revenue:

- Can be enacted at a local level, even within the territory of a large electric utility.
- Funds designated are simply credited to a specific account.
- No marketing expenses
- Stable income source for solar power producers

Disadvantage of a program relying on utility tax revenue:

- It's a tax

3. MEASURE THE SUPPLY OF SOLAR ENERGY

The supply of solar energy is measured by metering the solar energy produced by each solar power system. A standard utility-grade electric meter can be used to measure the number of solar kilowatt hours produced each year. This meter is NOT the home or business's normal consumption meter. This solar-only electric meter is NOT the net-metered amount.

There are three different ways to measure solar energy production. All three metering configurations are separate and distinct from the building's normal consumption meter.

To make the meters run forward when power is produced, the meter bases are simply wired with the solar output to the top lugs of the meter and the utility power lines to the bottom of the meter. Because the reads for power production are positive, they flow right into an electric utility's standard billing system. The meters can be read monthly or even annually

3.1 Independent Power Producer Metering

The metering configuration shown in Fig. 2 is for solar power systems that feed directly to the utility's power grid. The solar power installation is treated as a new electrical service connection. The solar is not connected in any way to the building's consumption meter and does not even require that there be a building. The solar power system could be mounted on a roof or it could be off by itself in a field.

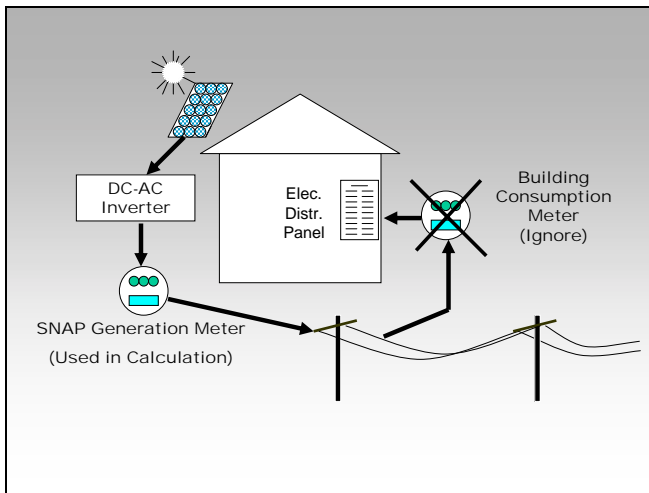

Fig. 2: Independent Power Producer SNAP Metering

Utilities may prefer this type of metering configuration because they do not lose any retail revenue when customers install solar power on their homes as is the case with standard net-metered systems. It is also a benefit to the utility because the utility can receive solar power at the wholesale power rate of only \$0.03 to \$0.05 per kWh. The higher premium price of up to \$1.50 per kWh would be paid by others, not the utility. Solar power producers may like this configuration because it gives them access to wholesale power rates for their power instead of retail rates.

The cost of reading the production meter is paid by the solar power producer. Chelan County PUD charges the producers \$3.65 a month to read their power production meter.

3.2 Net Metering Without Batteries

Figure 3 shows another method for metering the power output of the solar power system. This metering system still requires a separate meter to measure the power output of the inverter, but the solar output goes through the electrical distribution panel of the house or business. The power output also reduces the power as measured by the building's consumption meter. The advantage to the customer is that there is no added expense of a new separate electrical service. In addition to being paid a premium price for the solar-generated power, the customer also receives a credit on the normal consumption meter for any power produced. The down side is that the producer does not receive wholesale power rates for the solar-generated power.

The meter could be self-read by the solar power producer, the electric utility, or the organization running the solar power program.

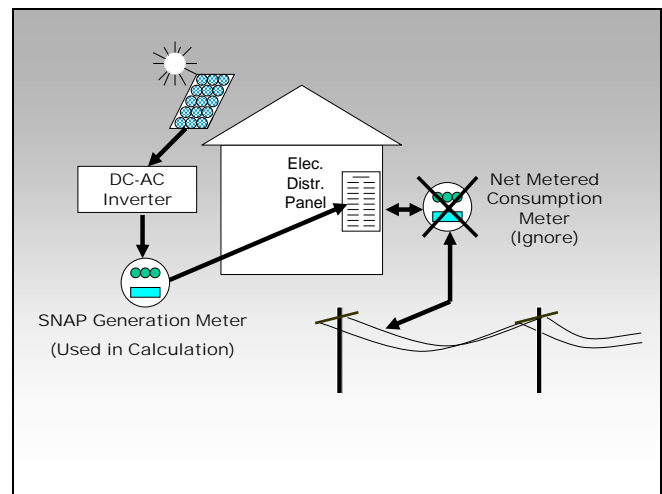

Fig. 3: SNAP Metering without Batteries

3.3 Net Metering With Batteries

It is more difficult to measure the solar energy produced by battery-powered systems. Not including the building's consumption meter, it takes at least two meters to measure the alternating current (AC) energy produced by a battery-inverter solar power system.

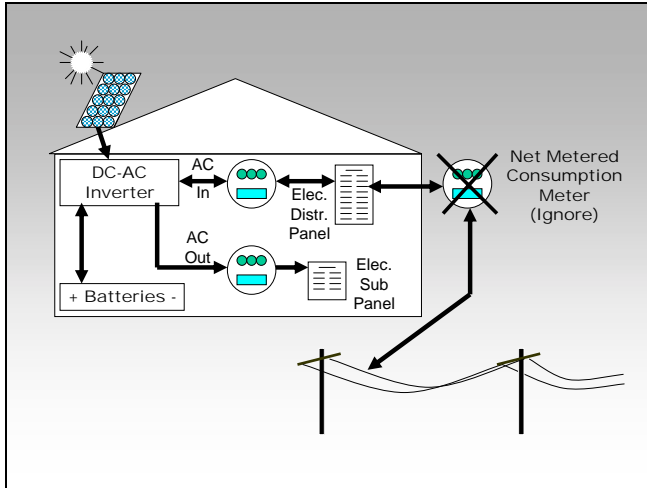

Fig. 4: SNAP Metering with Batteries

A battery-inverter typically has an AC input and an AC output. To measure the solar energy produced by the system it is necessary to install one meter on the AC input side of the inverter and another meter on the AC output of the inverter. The solar electricity produced by the solar power system with batteries is equal to:

$$\text{Solar Generated Energy} = \text{AC Out Meter} - \text{AC Input Meter}$$

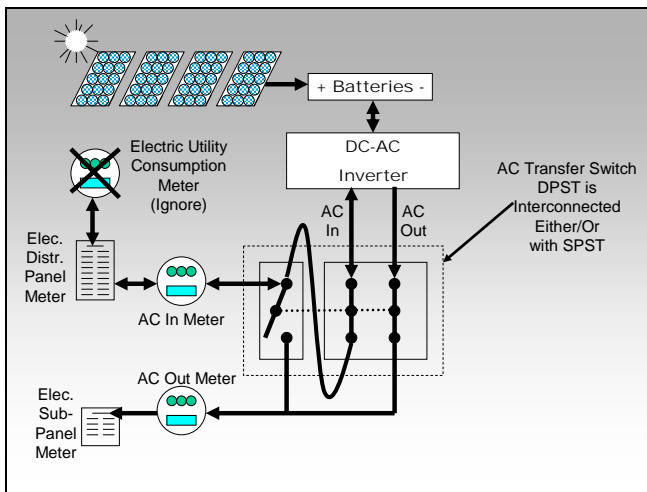

Fig. 5: AC Transfer Switch & Metering Details

Figure 5 shows the transfer switch arrangement for a battery-inverter system. In one position, all of the power to the electrical sub-panel is run through the inverter. If the solar output is greater than the loads on the sub-panel then the inverter automatically sends the excess power back through the “AC In” meter. The second position of the transfer switch disconnects the AC lines in and out of the inverter and feeds the sub-panel utility power directly from the main electrical distribution panel.

4. REBATES, GREEN TAGS, OR PERFORMANCE INCENTIVES

The goal of rebates, green tags, and performance incentives is to increase the amount of new renewable power that gets generated. Green tags and performance incentives are premium payments for new renewably generated energy (\$/kWh), whereas rebates are paid based on the installation cost of equipment (\$/kW). A good solar power program must maximize the amount of solar power generated while using the least amount of public funds.

4.1 Green Tags & Block Programs

Green tags or block programs offer fixed price blocks of kilowatt hours in exchange for a premium price of approximately one or two cents more per kWh. Solar green tags are offered at up to 10 cents per kWh. Customers choose to pay extra for a specified number of 100 kWh blocks or choose to have a certain percentage of their power provided from new alternative renewable resources. The extra money received from the customer is then paid to the alternative renewable power producer to make their project cost-effective.

These types of programs typically favor power generated by large wind turbines or biogas projects. They are effective at getting a large number of “green” kWh generated for the least cost. This is because one or two cents per kWh can be enough to make wind or biogas projects cost-effective over conventional fossil fuel power generation. Because solar power costs approximately \$0.25 to \$0.30 per kWh to generate, green tag or block programs are not very effective at spurring the development of new solar power installations.

4.2 Rebate Programs

Rebates improve the economics of solar by reducing the customer’s up-front cost of installing solar power equipment. Rebates can pay as much as \$4,500 per kW or 50% of the total installed cost. In order to ensure the systems perform as expected, there are relatively high administrative costs incurred in solar site evaluations, installation inspections, cost verification, and rebate check processing. Once installed, there is no guarantee that the systems will perform over the long term.

4.3 Performance Incentives

The SNAP program in Chelan County is similar to Germany’s very successful feed-in tariff program. Both programs improve the economics of solar power by increasing the rate paid for solar-generated energy. Since

customers are paid only for the power they produce, they have a strong incentive to make sure their system is installed for the least cost and that it continues to function over time. The solar generated electricity is measured by a dedicated power production meter that is separate from the building's regular consumption meter.

SNAP differs from Germany's program in that the price of solar power is not set by the government. Under SNAP, the price of power can go up or down depending on the amount of money available and the amount of solar generated electricity each year. Germany's program is currently paying about \$0.43 per kWh. The SNAP rate for solar power produced in Chelan County during 2003-04 was \$0.72 per kWh. During 2002-03 it was \$1.20 per kWh, and in 2001-02 it was \$1.50 per kWh.

4.4 Rebate vs. Performance Incentive Simple Payback Comparison

While simple payback is not the best method for making economic decisions, it is still the most commonly used financial analysis tools. Simple payback tends to favor performance-based programs over rebate programs.

For example, assume that the labor and material costs for a 1 kW solar power system is \$9,000. Electricity costs \$0.10 per kWh. In this example, the 1 kW solar power system will generate about 1,400 kWh per year, which is typical for a 1 kW array in central Washington state.

Description	Option One 50% Rebate	Option Two \$0.72/kWh Production Incentive
Total Installed Cost	\$9,000	\$9,000
Rebate	\$4,500	\$0
Solar Producer's Cost	\$4,500	\$9,000
Annual Solar Energy Produced	1,400	1,400 kWh/Year
Cost of Electricity	\$0.10	\$0.10 \$/kWh
Performance Incentive	\$0	\$0.72 \$/kWh
Total Annual Savings	\$140	\$1,148 \$/Year
Simple Payback	32	8 Years

In addition to having a lower simple payback, the advantage of performance incentives over rebate programs is that they:

1. Require less administrative overhead. Production payments are made by Chelan PUD once a year. Solar power production payments are based on actual meter reads as recorded by standard meter readers at the same time the customer's electrical consumption meter is read. Rebate programs require customers to document installation costs, have higher inspection costs, and require more administrative costs to evaluate acceptable

systems, estimate actual performance based on manufacturer ratings, etc.

2. Pay for actual production. Unlike rebate programs which only pay for installed equipment, performance programs pay only for actual production. Production payments ensure that the systems continue to function. There are many instances of rebate money going to systems that fail to perform as expected.
3. Drive down first costs. Rebate programs tend to keep installation costs up rather than bringing them down. During the first five years of California's rebate program, installation costs only went down an average of 1 percent per year.
4. Production payments are spread out over a longer period of time, as opposed to large upfront payments.
5. Create more solar investment per public dollar invested. Chelan PUD's program currently has a 12:1 ratio of installed systems per SNAP dollar spent. A 50% rebate program would have a ratio of 2:1, and that does not include administrative costs.

5. RESULTS

The performance incentive program in Chelan County has resulted in over \$700,000 of installed solar and small wind power systems that would not exist were it not for the PUD's production incentive program. Figure 6 shows one large solar installation that occurred as a result of the SNAP program. In addition to this and other SNAP installations, all 29 public schools and at least two private schools are scheduled to receive a 1.3 kW solar power system by the summer of 2004. By the end of June 2004, there is scheduled to be more grid-connected solar power in Chelan County than any other county in Washington state.



Fig. 6: Performing Arts Center 10 kW Solar Array

For more information on the SNAP program go to: www.chelanpud.org/snap.